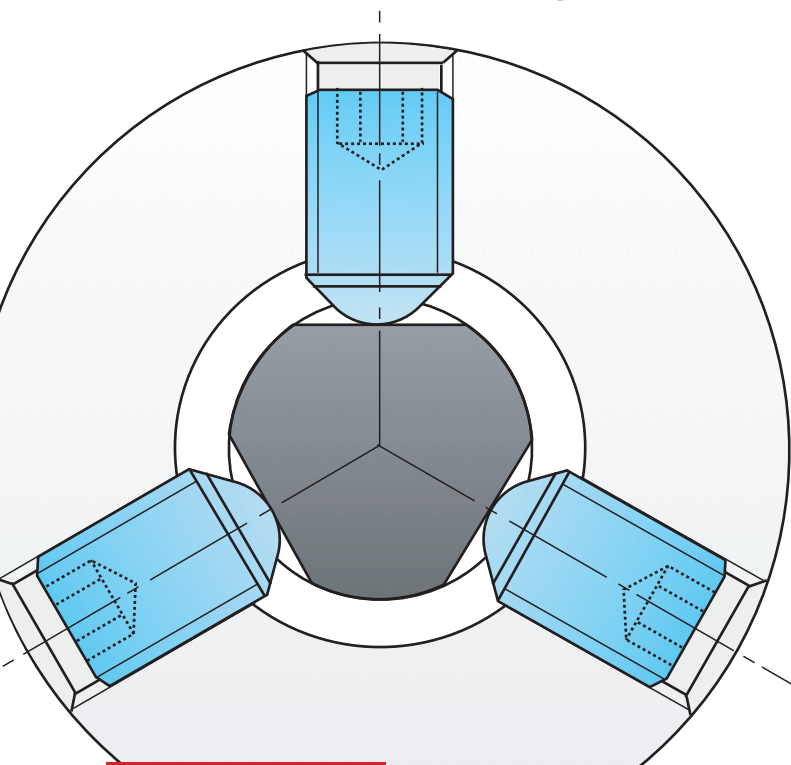

Fresa in metallo duro antiestrazione

- **Massima efficienza & sicurezza utilizzate in combinazione con il mandrino antiestrazione della serie Power**

**KAR-P3**

K-Mill Aero Radius
Power

KLS-P3

K-Mill Lega Square
Power

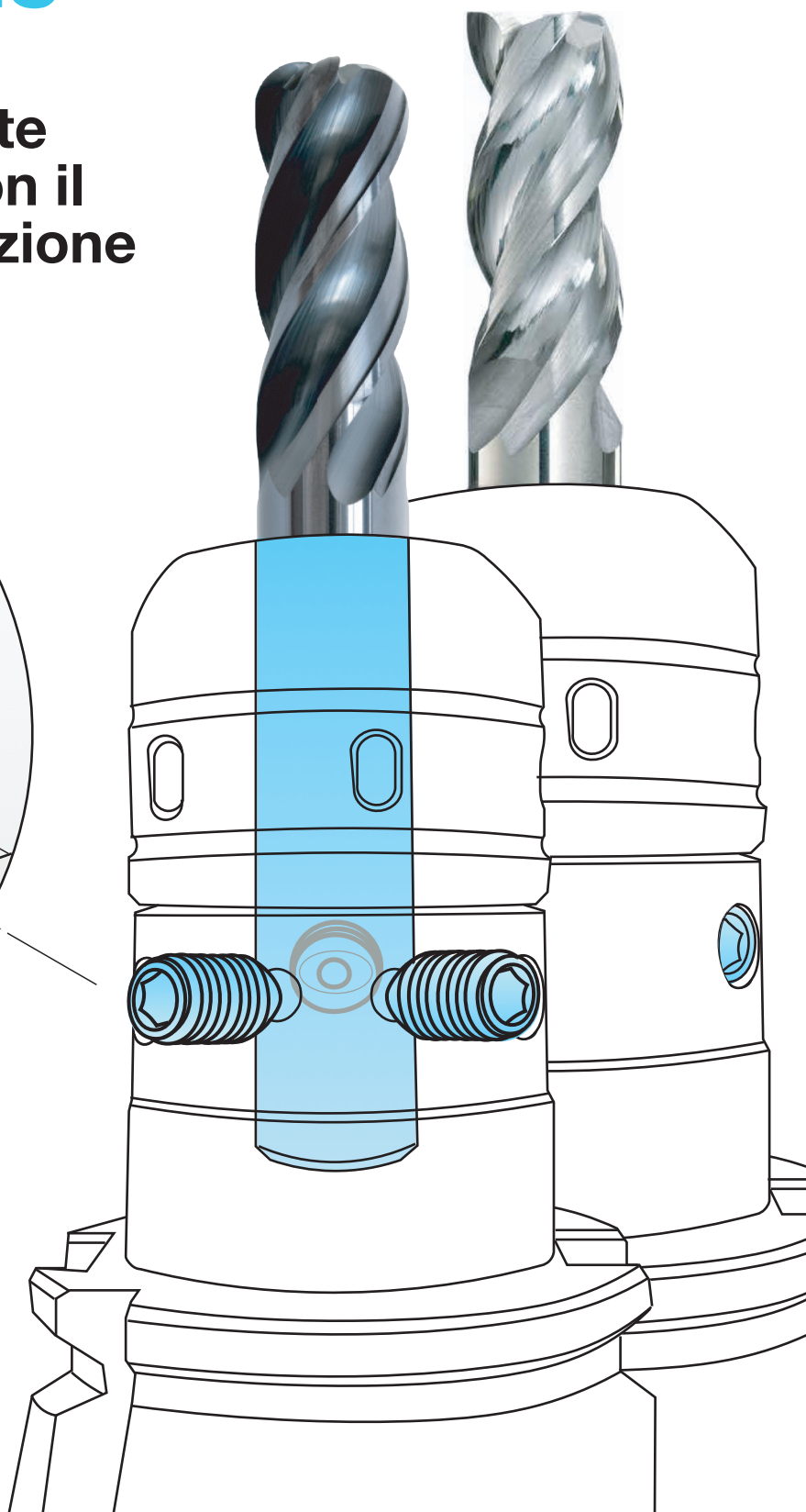

KAR-P3 | K-Mill Aero Radius - Power

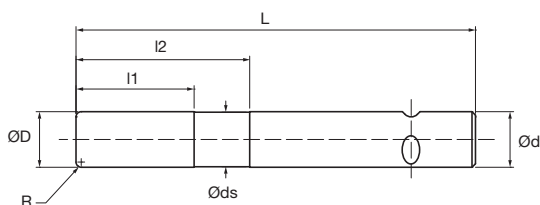

K-Mill
 Aero
 Radius
 Power
KAR4160-50-10-P3
 Z Diametro Utile Raggio

D	h10
R	±0,02
d	h6

Codice	D	R	l2	l1	ds	L	d
KAR4160-50-P3	16	0	50	34	15,7	115	16
KAR4160-50-10-P3	16	1	50	34	15,7	115	16
KAR4160-50-15-P3	16	1,5	50	34	15,7	115	16
KAR4160-50-20-P3	16	2	50	34	15,7	115	16
KAR4160-50-30-P3	16	3	50	34	15,7	115	16
KAR4200-62-P3	20	0	62	42	19,7	137	20
KAR4200-62-10-P3	20	1	62	42	19,7	137	20
KAR4200-62-15-P3	20	1,5	62	42	19,7	137	20
KAR4200-62-20-P3	20	2	62	42	19,7	137	20
KAR4200-62-30-P3	20	3	62	42	19,7	137	20

KLS-P3 | K-Mill Lega Square - Power

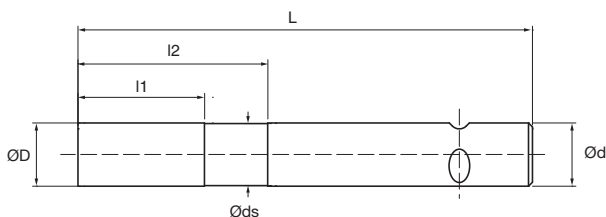

K-Mill
 Lega
 Square
 Power
KLS3160-50-P3
 Z Diametro Utile

D	h10
d	h6

Codice	D	l2	l1	ds	L	d
KLS3160-50-P3	16	50	34	15,8	115	16
KLS3200-62-P3	20	62	42	19,8	137	20

