



**D'ANDREA**<sup>®</sup>  
TECNOLOGY FOR HIGH PRECISION

# TOOLS HEADS 2022



Golden Compass  
award for industrial design



**D'ANDREA®**  
TECHNOLOGY FOR HIGH PRECISION

# TOOLS HEADS 2022



Golden Compass  
award for industrial design

# NEL SEGNO DELLA PRECISIONE

D'ANDREA S.p.A. è un'azienda italiana leader mondiale nella produzione di accessori di alta precisione per macchine utensili, fondata nel 1951 da Marino D'Andrea, che iniziò l'attività con l'introduzione della prima testa a sfacciare e barenare (TA). Il marchio D'Andrea è un brand internazionalmente riconosciuto, attraverso una rete distributiva presente in oltre 40 Paesi, per la qualità e l'affidabilità dei prodotti.



La produzione si divide tra la sede di Lainate, alle porte di Milano, coi suoi 7.000 mq di officina e uffici direzionali e lo stabilimento di Castel Del Giudice (Isernia) dove la D'ANDREA MOLISE produce, gran parte dei semilavorati dei componenti che vengono successivamente finiti, montati e collaudati nella sede principale.



Golden Compass  
award for industrial design



Una parte cospicua del profitto è reinvestito in Ricerca e Sviluppo di nuovi prodotti che, grazie a soluzioni tecnologiche avanzate, soddisfano una domanda molto qualificata. Un team tecnico-commerciale dedicato permette una veloce esecuzione di progetti speciali su specifiche del cliente. Negli anni, il range di barenatura e alesatura è arrivato a coprire dai diametri più piccoli (2 mm) ai grandi diametri (fino a 3 metri).

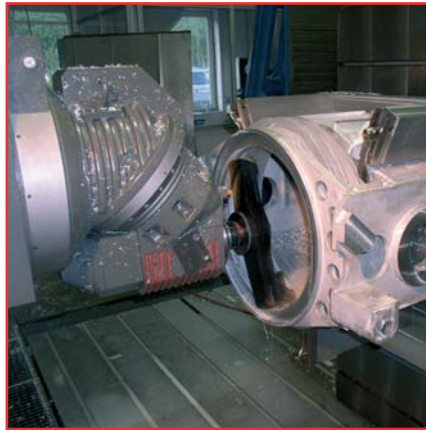

Una tradizione di 70 anni nel settore manifatturiero e una grande passione per la meccanica che oggi è ereditata dalla terza generazione, con l'obiettivo di rispondere alle richieste sempre più esigenti del mondo della meccanica di precisione.

Nella foto qui sopra Ermanno D'Andrea con i figli Amedeo, Maria Pina e Marino.





# PORTAUTENSILI

pag.  
10

*modulhard'andrea MHD' testarossad'andrea*



Portautensili **Modulari** MHD'

pag.  
64

**PSC** Linea



Portautensili **Modulari** PSC

pag.  
70

**MONO**force



Portautensili a Forte Serraggio

pag.  
74

**MONO**d'



Portautensili Monolitici

pag.  
100

## U-TRONIC



## UT-SPECIALI



Teste CN di medie e grandi dimensioni  
per alesatrici e unità speciali

pag.  
110

## TA-CENTER



Teste CN per centri di lavoro

pag.  
118

## TA-TRONIC



Teste CN per fresatrici

pag.  
124

## U-COMAX



Teste CN a comando assiale  
per macchine transfer e unità speciali

pag.  
130

## AUTORADIAL



Teste Automatiche  
per centri di lavoro e fresatrici

# PORTAUTENSILI MODULARI

*modulhard'andrea* MHD'

**ATTACCHI BASE**

**PR**  
Prolunghe

**RD**  
Riduzioni

**RAV**  
Riduzioni  
Antivibranti

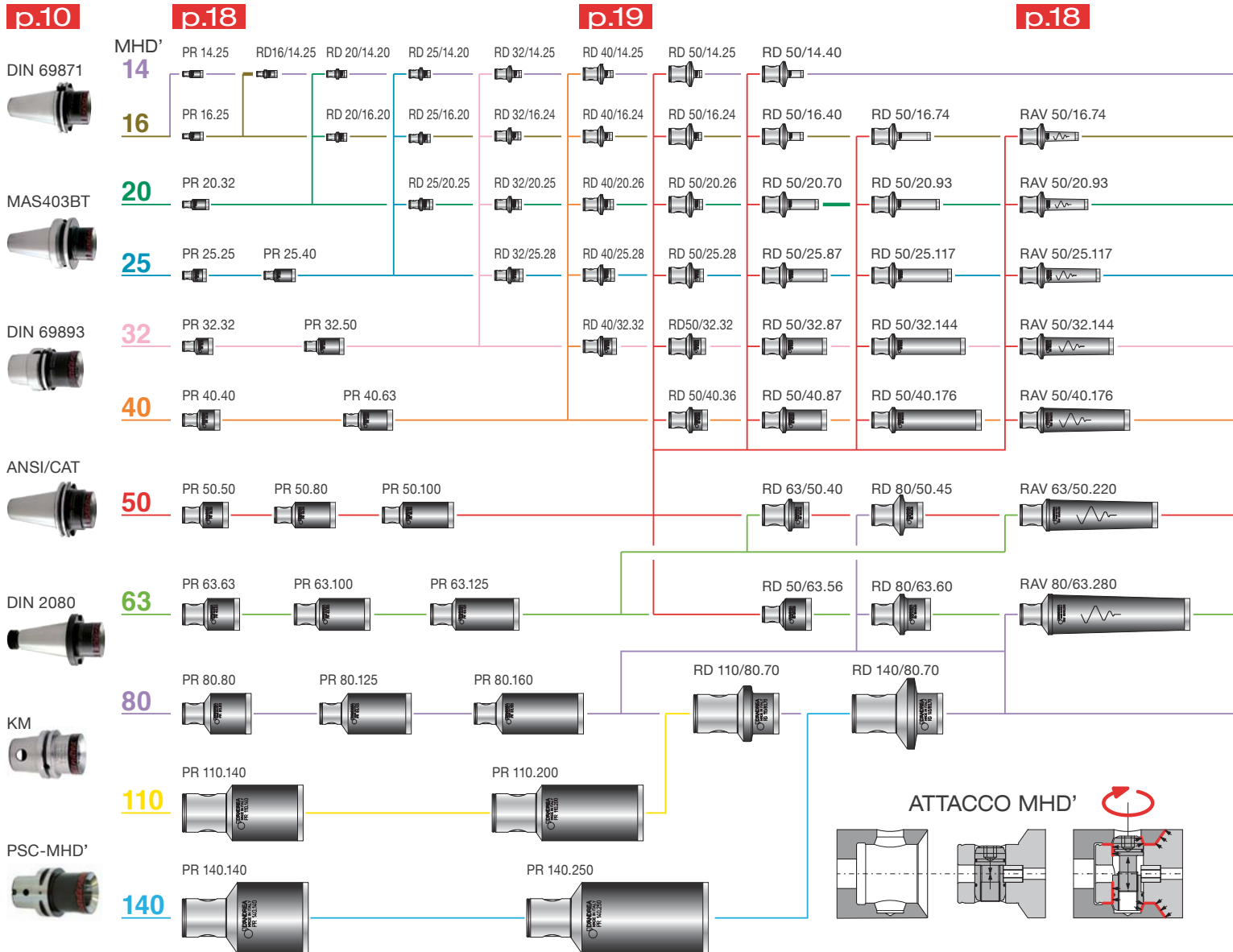

## Modular PSC Linea

**ATTACCHI BASE** **p.66**

**ATTACCHI BASE PROLUNGHE E RIDUZIONI** **p.68**

**ATTACCHI BASE PSC A RIDUZIONI MHD' p.68**

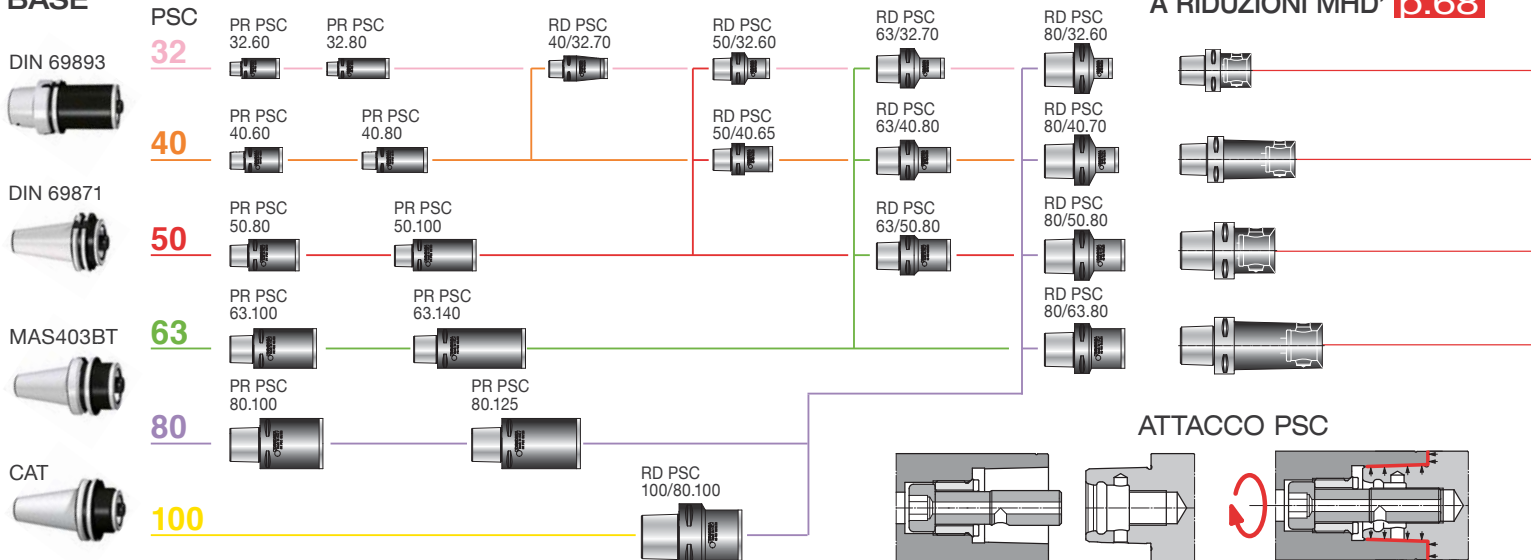

# testarossa d'andrea

**TS**  
Testine  
Sgrossatura  
**p.20**

**TRD**  
Testine  
Bitaglianti  
**p.26**

**TRM**  
Testine  
Micrometriche  
**p.28**

**TRC**  
Testine  
Centesimali  
**p.38**

**TRM HSB**  
Testine Alta Velocità  
Bilanciabili  
**p.46**

**TRE**  
Testine  
Digitali  
**p.48**

**BPS**  
Barre Portaseggio  
Ø 200 ~ 1200  
**p.56**

**ADATTATORI**  
**p.60**

2µm

TRC 14  
Ø 14.5 - 18

2µm

**TRC HS**  
Testine alta  
velocità  
**p.46**

2µm

TRM32HSB  
Ø 2.5 - 18

TRC32HS  
Ø 2.5 - 18

TRM50HSB  
Ø 2.5 - 22

TRC50HS  
Ø 2.5 - 22

TRE 32  
Ø 35.5 - 51.5

TRE 40  
Ø 48 - 64

TRE 50  
Ø 2.5 - 110

TRE 63  
Ø 6 - 125

TRE 80  
Ø 6 - 200

TS 16/16  
Ø 18 - 22

TS 20/20  
Ø 22 - 28

TS 25/25  
Ø 28 - 38

TS 32/32  
Ø 35.5 - 50

TS 40/40  
Ø 50 - 68

TS 50/50 - 50/63  
Ø 68 - 90

TS 63/63  
Ø 90 - 120

TS 80/80  
Ø 120 - 200

TRM 16  
Ø 18 - 23

TRM 20  
Ø 22 - 29

TRM 25  
Ø 28 - 38

TRM 32  
Ø 35.5 - 50

TRM 40  
Ø 48 - 63

TRM 50  
Ø 2.5 - 108

TRM 50/63 - 50/80  
TRM 63/63 - 80/80  
Ø 2.5 - 160

TRM 80 - 125  
Ø 2.5 - 500

TRD 25  
Ø 28 - 36

TRD 32  
Ø 36 - 46

TRD 40  
Ø 46 - 60

TRD 50  
Ø 60 - 75

TRD 63  
Ø 75 - 95

TRD 80  
Ø 95 - 160

TRC 16  
Ø 18 - 24

TRC 20  
Ø 22 - 30

TRC 25  
Ø 28 - 40

TRC 32  
Ø 35 - 53

TRC 40  
Ø 48 - 66

TRC 50  
Ø 2.5 - 110

TRC 63  
Ø 6 - 125

TRC 80  
Ø 6 - 200

**KIT**  
Testarossa



SGROSSATURA

FINITURA

TRE 200

TR 200

2µm

MHD'

PSC

MONOd'

ISO D.60

PE  
Adattatori portapinz  
elastiche

MHD' FORCE  
Adattatori a forte  
serraggio

AW  
Adattatori combinati

PF  
Adattatori portafrese  
combinati

AM  
Adattatori di maschiatura

NS  
Adattatori semilavorati

ACR  
Adattatori per liquido  
refrigerante

MAX.10  
BAR

SPECIALI

## PSC ATTACCHI BASE PER FRESATURA - FORATURA

PORTAFRESE

**p.69**

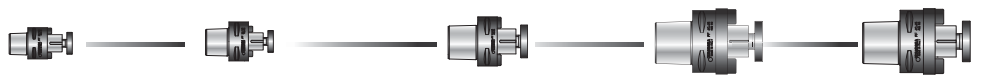

PSC NS-H.28-42

**p.69**

Adattatori Semilavorati



MONOforce

**p.69**

Forte Serraggio



INSERTI

**p.62**

ACCESSORI

**p.80**

RICAMBI

**p.84**

DATI TECNICI

**p.92**

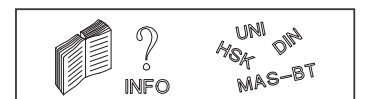
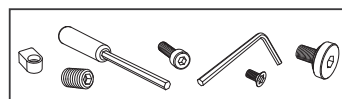
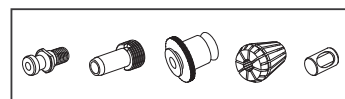
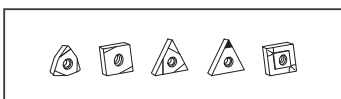



# modulhard'andrea MHD'

È una linea di portautensili modulari di alta precisione che consente di eseguire con estrema flessibilità e rigidità operazioni di alesatura, fresatura, foratura e maschiatura.

L'**attacco MHD'** è il punto di forza del Modulhard'andrea: disponibile in undici grandezze, garantisce l'intercambiabilità di tutti gli elementi del sistema, che include attacchi base, prolunghe, riduzioni e adattatori portautensili.



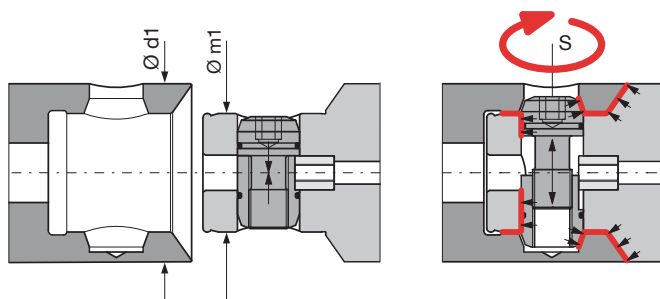

MHD'	Ø d1	Ø m1	S	⬡ Nm
MHD' 14	14	10	2,5	2 - 2,5
MHD' 16	16	10	2,5	2 - 2,5
MHD' 20	20	13	3	4 - 4,5
MHD' 25	25	16	3	6,5 - 7,5
MHD' 32	32	20	4	7 - 8
MHD' 40	40	25	5	16 - 18
MHD' 50	50	32	6	30 - 35
MHD' 63	63	42	8	70 - 80
MHD' 80	80	42	8	70 - 80
MHD' 110	110	76	14	200 - 220
MHD' 140	140	76	14	200 - 220



Il ricco **programma di alesatura** completa la linea MHD' con un'ampia gamma di testine di sgrossatura bitaglienti e testine di finitura digitali, micrometriche e centesimali.

**ATTACCHI BASE** realizzati secondo normative DIN 69871, MAS 403 BT, DIN 2080, ANSI-CAT, DIN 69893, ISO 26623-1 e costruiti in acciaio cementato, temprato e rettificato BILANCIATURA 8000 RPM.

**PR** Per ogni grandezza MHD' esistono prolunghe di diverse lunghezze che consentono di raggiungere le profondità di lavorazione desiderate.

**RD** Le riduzioni permettono di utilizzare componenti MHD' di una grandezza più piccola e quindi ottimizzare la composizione dell'utensile in funzione degli ingombri.

**RAV** Riduzioni antivibranti per lavorazioni profonde o gravose.

**TS** Testine di sgrossatura semplici ed estremamente rigide grazie alle superfici di contatto dentellate tra il corpo testa e i seggi portainsero. La distanza costante tra la vite di serraggio del seggio ed il tagliente garantisce la stabilità del sistema.

**TRD** Testine bitaglienti che consentono lavorazioni combinate di sgrossatura e finitura di alta precisione grazie alla regolazione centesimale, leggibile sul nonio ed eseguibile anche in macchina.

**TRM** Testine micrometriche per lavorazioni di alta precisione con grado di tolleranza **IT6**. La regolazione è facilmente leggibile sul nonio ed eseguibile anche in macchina.

**TRC** Testine centesimali per lavorazioni di alta precisione con grado di tolleranza **IT7**. La regolazione è facilmente leggibile sul nonio ed eseguibile anche in macchina.

**TRC HS e TRM HSB** Testine centesimali (HS) e micrometriche (HSB) per lavorazioni ad alta velocità.

**TRE** Testine micrometriche digitali di finitura per lavorazioni di alta precisione con grado di tolleranza **IT6**. La visualizzazione della regolazione sul display integrato è veloce e precisa e le TR-ELETTRA sono resistenti all'ingresso di liquidi secondo il grado di protezione **IP69K**.

**BPS** barre in alluminio per lavorazioni di grandi diametri. Utilizzabili sia per sgrossatura che per finitura, coprono un campo di lavoro da 200 a 1200 mm

**ADATTATORI** Il completo programma di adattatori modulari D'Andrea con attacco MHD', che soddisfa svariate esigenze di lavorazione in fresatura, foratura e maschiatura.



DIN 69871 AD

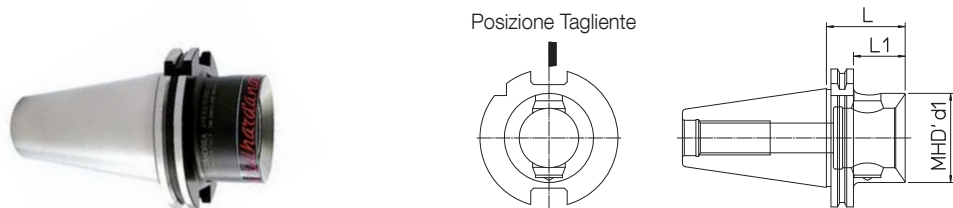

DIN	REF.	CODE	MHD' d1	L	L1	kg	• Salvo disponibilità magazzino
30	DIN69871-A30 MHD'32.30	416320103020 •	32	30	11	0.4	
30	DIN69871-A30 MHD'40.45.5	416400103020 •	40	45.5	26.5	0.5	
30	DIN69871-A30 MHD'50.60	416500103020	50	60		0.6	
40	DIN69871-A40 MHD'40.45	416400104020	40	45	26	0.5	
40	DIN69871-A40 MHD'50.48	416500104020	50	48	29	0.9	
40	DIN69871-A40 MHD'50.56	416500104070	50	56	37	1.1	
40	DIN69871-A40 MHD'63.80	416630104020	63	80		1.5	
45	DIN69871-A45 MHD'50.48	416500104520	50	48	29	1.7	
50	DIN69871-A50 MHD'50.48	416500105020	50	48	29	2.5	
50	DIN69871-A50 MHD'63.48	416630105029	63	48	29	2.6	
50	DIN69871-A50 MHD'63.56	416630105020	63	56	37	2.8	
50	DIN69871-A50 MHD'80.48	416800105029	80	48	29	3	
50	DIN69871-A50 MHD'80.62	416800105020	80	62	43	3.4	
50	DIN69871-A50 MHD'110.150	416910105020	110	150		7.6	
50	DIN69871-A50 MHD'140.160	416940105020 •	140	160		10	
60	DIN69871-A60 MHD'50.50	416500106020 •	50	50	31	8.3	
60	DIN69871-A60 MHD'63.60	416630106020 •	63	60	41	9.3	
60	DIN69871-A60 MHD'80.65	416800106020 •	80	65	46	10.3	
60	DIN69871-A60 MHD'110.100	416910106020 •	110	100	81	10.5	
60	DIN69871-A60 MHD'110.200	416910106028 •	110	200	181	18	
60	DIN69871-A60 MHD'140.100	416940106020 •	140	100	81	12.8	
60	DIN69871-A60 MHD'140.250	416940106028 •	140	250	231	30	

DIN 69871 B

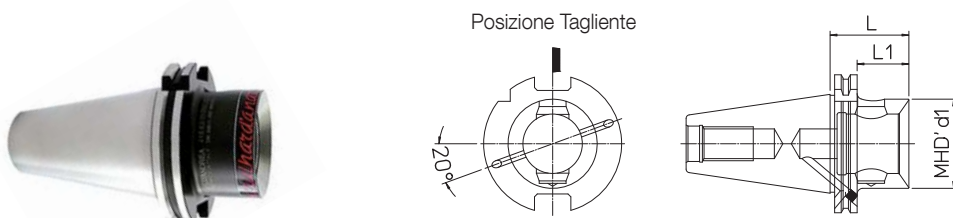

DIN	REF.	CODE	MHD' d1	L	L1	kg	• Salvo disponibilità magazzino
40	DIN69871-B40 MHD'50.48	416500104021	50	48	29	0.9	
40	DIN69871-B40 MHD'63.80	416630104021 •	63	80		1.5	
45	DIN69871-B45 MHD'50.48	416500104521 •	50	48	29	1.7	
50	DIN69871-B50 MHD'50.48	416500105021	50	48	29	2.7	
50	DIN69871-B50 MHD'63.56	416630105021	63	56	37	2.8	
50	DIN69871-B50 MHD'80.62	416800105021	80	62	43	3.4	

## DIN 69871 AD+B



Posizione Tagliente

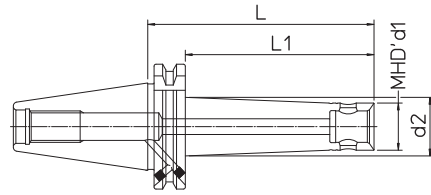
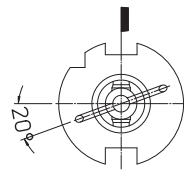

DIN	REF.	CODE	MHD' d1	d2	L	L1	kg	• Salvo disponibilità magazzino
40	DIN69871-AD+B40 MHD'16.40	416160414021 •	16		40	21	0.7	
40	DIN69871-AD+B40 MHD'16.63	416160614021	16	17.5	63	44	0.8	
40	DIN69871-AD+B40 MHD'16.100	416161014021	16	20	100	81	0.9	
40	DIN69871-AD+B40 MHD'20.50	416200514021	20		50	31	0.8	
40	DIN69871-AD+B40 MHD'20.80	416200814021	20	22.5	80	61	0.9	
40	DIN69871-AD+B40 MHD'20.125	416201214021	20	25.5	125	106	1	
40	DIN69871-AD+B40 MHD'25.50	416250514021	25		50	31	0.9	
40	DIN69871-AD+B40 MHD'25.80	416250814021	25	27	80	61	1	
40	DIN69871-AD+B40 MHD'25.125	416251214021	25	30	125	106	1.1	
40	DIN69871-AD+B40 MHD'32.50	416320514021	32		50	31	1	
40	DIN69871-AD+B40 MHD'32.80	416320814021	32	33.5	80	61	1.1	
40	DIN69871-AD+B40 MHD'32.125	416321214021	32	36.5	125	106	1.2	

## DIN 69871 AD+B



Posizione Tagliente

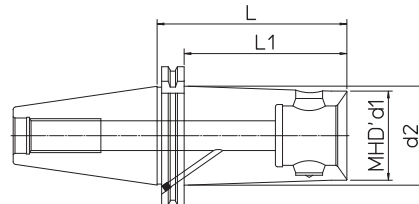
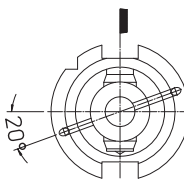

DIN	REF.	CODE	MHD' d1	d2	L	L1	kg
40	DIN69871-AD+B40 MHD'40.120	416400104028	40	44.5	120	101	1.4
40	DIN69871-AD+B40 MHD'50.120	416500104028	50		120	101	1.7
50	DIN69871-AD+B50 MHD'50.120	416500105028	50	60	120	101	3.5
50	DIN69871-AD+B50 MHD'63.150	416630105028	63	70	150	131	5
50	DIN69871-AD+B50 MHD'80.180	416800105028	80		180	161	7.6

## DIN 69871 FC AD+B FACE CONTACT

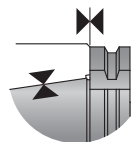

Posizione Tagliente

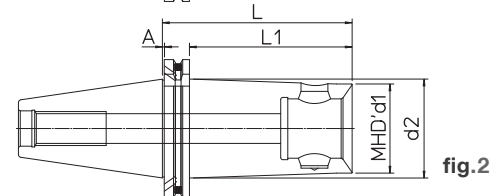
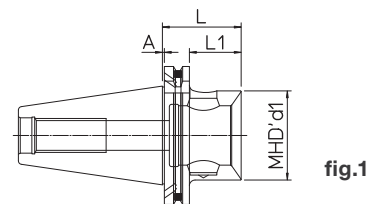
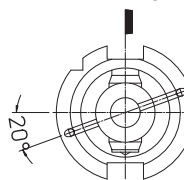

DIN	REF.	CODE	MHD' d1	d2	A	L	L1	Kg.	fig.	• Salvo disponibilità magazzino
40	DIN69871-AD+B40 FC MHD'50.48	416500104021F	50	1	48	29	0.9	1		
40	DIN69871-AD+B40 FC MHD'50.120	416500104028F •	50	1	120	101	1.7	1		
40	DIN69871-AD+B40 FC MHD'63.80	416630104021F	63	1	80		1.5	1		
50	DIN69871-AD+B50 FC MHD'50.48	416500105021F	50	1.5	48	29	2.5	1		
50	DIN69871-AD+B50 FC MHD'50.120	416500105028F	50	59	1.5	120	101	3.5	2	
50	DIN69871-AD+B50 FC MHD'50.200	416500105027F	50	68	1.5	200	181	6.1	2	
50	DIN69871-AD+B50 FC MHD'63.56	416630105021F	63	1.5	56	37	2.8	1		
50	DIN69871-AD+B50 FC MHD'63.150	416630105028F	63	75.5	1.5	150	131	5.2	2	
50	DIN69871-AD+B50 FC MHD'63.250	416630105027F	63	80	1.5	250	231	7.1	2	
50	DIN69871-AD+B50 FC MHD'80.62	416800105021F	80	1.5	62	43	3.4	1		
50	DIN69871-AD+B50 FC MHD'80.180	416800105028F	80	1.5	180	161	6.9	1		
50	DIN69871-AD+B50 FC MHD'80.300	416800105027F	80	1.5	300	281	9.2	1		
50	DIN69871-AD+B50 FC MHD'110.150	416910105021F •	110	1.5	150		8	1		
50	DIN69871-AD+B50 FC MHD'110.250	416910105028F •	110	1.5	250		15	1		



MAS 403 BT AD



Posizione Tagliente

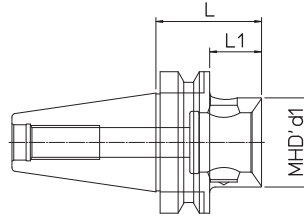
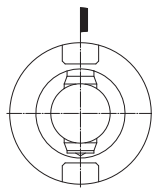

BT	REF.	CODE	MHD' d <sub>1</sub>	L	L <sub>1</sub>	kg	• Salvo disponibilità magazzino
30	MAS403 BT30 MHD'32.32	416320103030	32	32	10.5	0.5	
30	MAS403 BT30 MHD'40.35.5	416400103030 •	40	35.5	14	0.6	
30	MAS403 BT30 MHD'50.60	416500103030	50	60		0.7	
40	MAS403 BT40 MHD'40.45	416400104030	40	45	18	0.6	
40	MAS403 BT40 MHD'50.38.5	416500104039	50	38.5	11.5	0.8	
40	MAS403 BT40 MHD'50.48	416500104030	50	48	21	0.9	
40	MAS403 BT40 MHD'50.56	416500104080	50	56	29	1.1	
40	MAS403 BT40 MHD'63.66	416630104030	63	66		1.2	
45	MAS403 BT45 MHD'50.62	416500104530 •	50	62	29	1.7	
50	MAS403 BT50 MHD'50.66	416500105030	50	66	28	3.3	
50	MAS403 BT50 MHD'63.50	416630105039	63	50	12	3.4	
50	MAS403 BT50 MHD'63.75	416630105030	63	75	37	3.7	
50	MAS403 BT50 MHD'80.50	416800105039	80	50	12	3.8	
50	MAS403 BT50 MHD'80.75	416800105030	80	75	37	4	
50	MAS403 BT50 MHD'110.140	416910105030 •	110	140		6.8	
50	MAS403 BT50 MHD'140.150	416940105030 •	140	150		9.2	
60	MAS403 BT60 MHD'110.110	416910106030 •	110	110	63	11.5	
60	MAS403 BT60 MHD'110.200	416910106038 •	110	200	152	18.1	
60	MAS403 BT60 MHD'140.100	416940106030 •	140	100	52	12.9	
60	MAS403 BT60 MHD'140.250	416940106038 •	140	250	202	30.1	

MAS 403 BT B



Posizione Tagliente

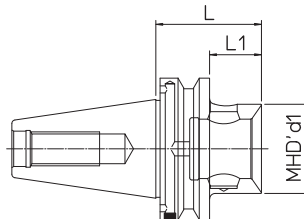
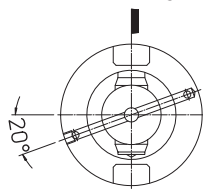

DIN	REF.	CODE	MHD' d <sub>1</sub>	L	L <sub>1</sub>	kg	• Salvo disponibilità magazzino
40	MAS403 BT40B MHD'50.48	416500104031	50	48	21	0.9	
40	MAS403 BT40B MHD'63.66	416630104031	63	66		1.2	
50	MAS403 BT50B MHD'50.66	416500105031	50	66	28	3.5	
50	MAS403 BT50B MHD'63.75	416630105031 •	63	75	37	3.7	
50	MAS403 BT50B MHD'80.75	416800105031 •	80	75	37	4	

## MAS 403 BT AD+B

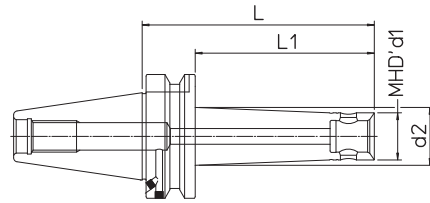
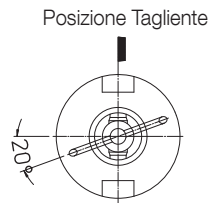

BT	REF.	CODE	MHD' d1	d2	L	L1	kg
40	MAS403 BT40-AD+B MHD'16.45	416160414031	16		45	18	0.8
40	MAS403 BT40-AD+B MHD'16.63	416160614031	16	17	63	36	0.9
40	MAS403 BT40-AD+B MHD'16.100	416161014031	16	19.5	100	73	1
40	MAS403 BT40-AD+B MHD'20.50	416200514031	20		50	23	0.9
40	MAS403 BT40-AD+B MHD'20.80	416200814031	20	22	80	53	1
40	MAS403 BT40-AD+B MHD'20.125	416201214031	20	25	125	98	1.1
40	MAS403 BT40-AD+B MHD'25.50	416250514031	25		50	23	1
40	MAS403 BT40-AD+B MHD'25.80	416250814031	25	26.5	80	53	1.1
40	MAS403 BT40-AD+B MHD'25.125	416251214031	25	29.5	125	98	1.2
40	MAS403 BT40-AD+B MHD'32.50	416320514031	32			23	1.1
40	MAS403 BT40-AD+B MHD'32.80	416320814031	32	33	80	53	1.2
40	MAS403 BT40-AD+B MHD'32.125	416321214031	32	36	125	98	1.4

## MAS 403 BT AD+B

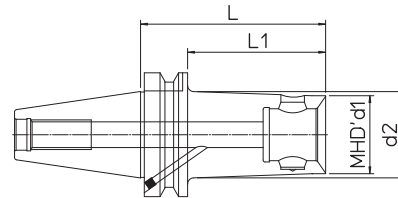
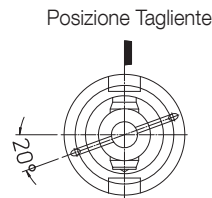

BT	REF.	CODE	MHD' d1	d2	L	L1	kg
40	MAS403 BT40-AD+B MHD'40.120	416400104038	40	44.5	120	93	0.9
40	MAS403 BT40-AD+B MHD'50.120	416500104038	50		120	93	1.9
50	MAS403 BT50-AD+B MHD'50.120	416500105038	50	60	120	82	4.2
50	MAS403 BT50-AD+B MHD'63.150	416630105038	63	70	150	112	5.8
50	MAS403 BT50-AD+B MHD'80.180	416800105038	80		180	142	7.5

## MAS 403 BT FC AD+B FACE CONTACT

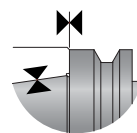

Posizione Tagliente

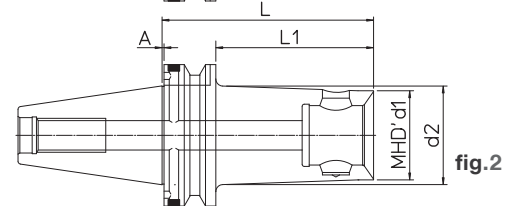
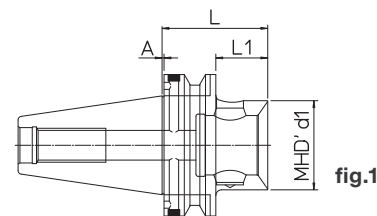
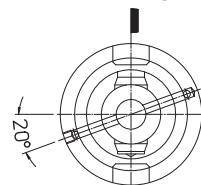

BT	REF.	CODE	MHD' d1	d2	A	L	L1	kg	fig.	• Salvo disponibilità magazzino
40	MAS403 BT40 FC AD+B MHD'50.48	416500104031F	50	1	48	21	0.9	1		
40	MAS403 BT40 FC AD+B MHD'50.120	416500104038F •	50	1	120	93	1.9	1		
40	MAS403 BT40 FC AD+B MHD'63.66	416630104031F	63	1	66		1.2	1		
50	MAS403 BT50 FC AD+B MHD'50.66	416500105031F	50	1.5	66	28	3.2	1		
50	MAS403 BT50 FC AD+B MHD'63.75	416630105031F	63	1.5	75	37	3.7	1		
50	MAS403 BT50 FC AD+B MHD'50.120	416500105038F	50	57.5	1.5	120	82	4.2	2	
50	MAS403 BT50 FC AD+B MHD'50.200	416500105037F	50	66	1.5	200	162	4.5	2	
50	MAS403 BT50 FC AD+B MHD'63.150	416630105038F	63	73.5	1.5	150	112	5.8	2	
50	MAS403 BT50 FC AD+B MHD'63.250	416630105037F	63	84	1.5	250	212	6.1	2	
50	MAS403 BT50 FC AD+B MHD'80.75	416800105031F	80	1.5	75	37	4	1		
50	MAS403 BT50 FC AD+B MHD'80.180	416800105038F	80	1.5	180	142	7.5	1		
50	MAS403 BT50 FC AD+B MHD'80.300	416800105037F	80	1.5	300	262	9.2	1		
50	MAS403 BT50 FC AD+B MHD'110.150	416910105031F •	110	1.5	150		8.1	1		
50	MAS403 BT50 FC AD+B MHD'110.250	416910105038F •	110	1.5	250		15.3	1		

**DIN 69893 HSK-A**



Posizione Tagliente

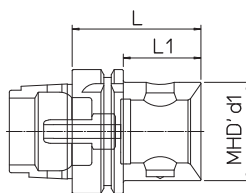
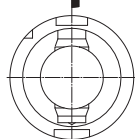

Completo di raccordo per il refrigerante

- ◆ Fornibili a richiesta versione HSK-T
- Salvo disponibilità magazzino

HSK-A	REF.	CODE	MHD' d1	L	L1	kg	
40	HSK-A40 MHD'32.48	416321504020 •	32	48	28	0.4	Fornito senza foro
50	HSK-A50 MHD'50.66	416501505020	50	66		0.6	
63	HSK-A63 MHD'40.60	416401506320 ◆	40	60	34	0.7	
63	HSK-A63 MHD'50.66	416501506320 ◆	50	66	40	0.9	
63	HSK-A63 MHD'63.75	416631506320 ◆	63	75		1.1	
80	HSK-A80 MHD'50.70	416501508020	50	70	44	1.5	
80	HSK-A80 MHD'63.80	416631508020	63	80	54	1.8	
80	HSK-A80 MHD'80.86	416801508020 •	80	86		2.1	
100	HSK-A100 MHD'50.72	416501510020 ◆	50	72	43	2.4	
100	HSK-A100 MHD'63.82	416631510020 ◆	63	82	53	2.7	
100	HSK-A100 MHD'80.88	416801510020	80	88	59	3	

**DIN 69893 HSK-A**



Posizione Tagliente

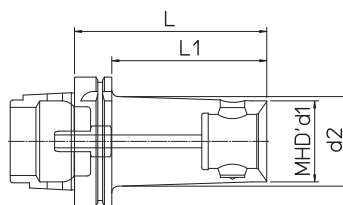
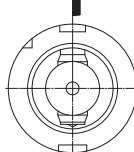

Completo di raccordo per il refrigerante

HSK-A	REF.	CODE	MHD' d1	d2	L	L1	kg	
63	HSK-A63 MHD'40.120	416401506328	40	46	120	94	1.4	
63	HSK-A63 MHD'50.120	416501506328	50		120	94	1.7	
100	HSK-A100 MHD'50.120	416501510028	50	60	120	91	3.2	
100	HSK-A100 MHD'63.150	416631510028	63	70	150	121	4.5	
100	HSK-A100 MHD'80.180	416801510028	80		180	151	6.5	

**DIN 69893 HSK-A**



Posizione Tagliente

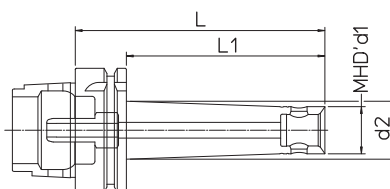
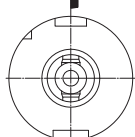

Completo di raccordo per il refrigerante

- Salvo disponibilità magazzino

HSK-A	REF.	CODE	MHD' d1	d2	L	L1	kg	
63	HSK-A63 MHD'16.63	416160656320	16	17	63	37	0.7	
63	HSK-A63 MHD'16.100	416161056320	16	19.5	100	74	0.8	
63	HSK-A63 MHD'20.63	416200656320 •	20		63	37	0.6	
63	HSK-A63 MHD'20.90	416200956320	20	22.5	90	64	0.8	
63	HSK-A63 MHD'20.125	416201256320 •	20	25	125	99	0.9	
63	HSK-A63 MHD'25.63	416250656320	25		63	37	0.7	
63	HSK-A63 MHD'25.90	416250956320	25	27	90	64	0.9	
63	HSK-A63 MHD'25.125	416251256320	25	29.5	125	99	1	
63	HSK-A63 MHD'32.90	416320956320	32	33.5	90	64	1	
63	HSK-A63 MHD'32.125	416321256320	32	36	125	99	1.2	

**DIN 69893 HSK-E**



Posizione Tagliente

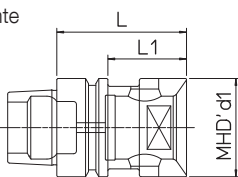

**DIN 69893 HSK-F**



Posizione Tagliente

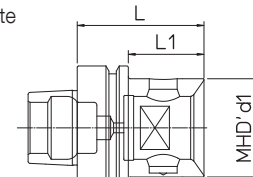
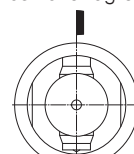

• Salvo disponibilità magazzino

HSK	REF.	CODE	MHD' d1	L	L1	kg	
40	HSK-E40 MHD'32.42	416321504025	32	42	22	0.5	
50	HSK-E50 MHD'50.66	416501505025 •	50	66		0.6	
63	HSK-E63 MHD'50.66	416501506325	50	66	40	0.9	
63	HSK-F63 MHD'50.65	416501506326	50	65	39	0.8	

PSC-MHD' ISO 26623-1

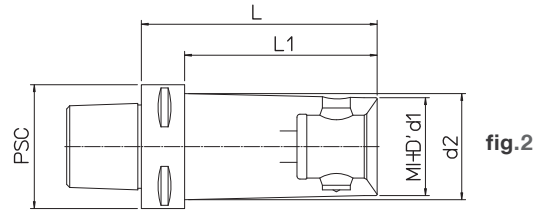
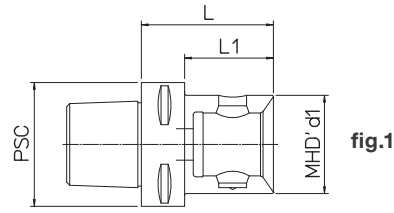

PSC	REF.	CODE	MHD' d1	d2	L	L1	Kg.	fig.
40	PSC 40 - MHD' 32.42	416322604004	32	42	22	0.3	1	
40	PSC 40 - MHD' 40.45	416402604004	40	45		0.4	1	
50	PSC 50 - MHD' 50.55	416502605005	50	55		0.8	1	
63	PSC 63 - MHD' 40.50	416402606305	40	50	28	0.9	1	
63	PSC 63 - MHD' 40.120	416402606312	40	44	120	98	1.5	2
63	PSC 63 - MHD' 50.55	416502606305	50	55	33	0.8	1	
63	PSC 63 - MHD' 50.67	416502606306	50	67	45	1.1	1	
63	PSC 63 - MHD' 50.120	416502606312	50	54	120	98	1.9	2
63	PSC 63 - MHD' 63.77	416632606307	63	77		1.8	1	
80	PSC 80 - MHD' 50.60	416502608006	50	60	30	2	1	
80	PSC 80 - MHD' 50.120	416502608012	50	54	120	90	2.8	2
80	PSC 80 - MHD' 63.70	416632608007	63	70	40	2.3	1	
80	PSC 80 - MHD' 63.150	416632608015	63	67	150	120	4	2
80	PSC 80 - MHD' 80.75	416802608007	80	75		2.6	1	
80	PSC 80 - MHD' 80.120	416802608012	80	120		4.3	1	
100	PSC 100 - MHD' 80.80	416802610008	110	80	44	3.5	1	
100	PSC 100 - MHD' 110.120	416912610012	110	120	84	5	1	

KM XMZ ISO 26622-1

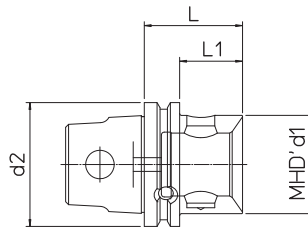

KM XMZ	REF.	CODE	MHD' d1	d2	L	L1	kg	
63	RD KM - MHD' 50.50	657095005063	50	63	50	32	0.8	• Salvo disponibilità magazzino
63	RD KM - MHD' 63.70	657096305063 •	63	63	70		1.2	



### ANSI/CAT AD

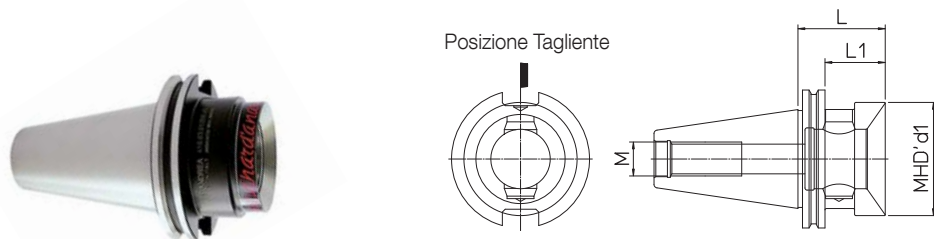

ANSI/CAT	REF.	CODE	MHD' d1	L	L1	M	kg	• Salvo disponibilità magazzino
40	ANSI/CAT40 MHD'50.66	416500104040	50	66	47	M16	1.1	
40	ANSI/CAT40 MHD'63.100	416630104040 •	63	100		M16	1.9	
45	ANSI/CAT45 MHD'50.48	416500104540 •	50	48	29	M20	1.7	
50	ANSI/CAT50 MHD'50.48	416500105040	50	48	29	M24	2.4	
50	ANSI/CAT50 MHD'63.56	416630105040 •	63	56	37	M24	2.9	
50	ANSI/CAT50 MHD'80.62	416800105040	80	62	43	M24	3.2	

### DIN 2080-A 'OTT'

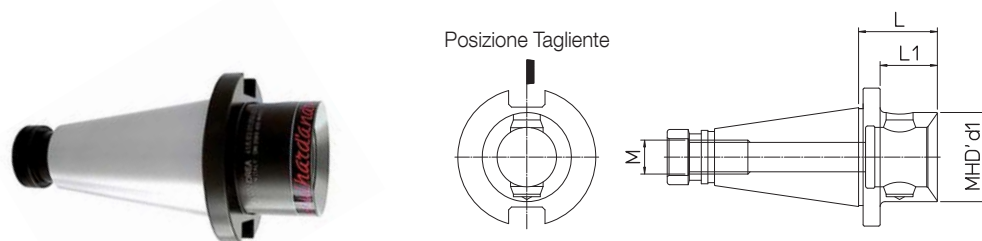

DIN	REF.	CODE	MHD' d1	L	L1	M	kg	• Salvo disponibilità magazzino
30	DIN2080-A30 MHD'50.58	416500103000	50	58		M12	0.6	
40	DIN2080-A40 MHD'50.48	416500104000	50	48	36.5	M16	0.9	
40	DIN2080-A40 MHD'63.60	416630104000	63	60		M16	1.2	
45	DIN2080-A45 MHD'50.48	416500104500 •	50	48	33	M20	1.6	
50	DIN2080-A50 MHD'50.48	416500105000	50	48	33	M24	2.6	
50	DIN2080-A50 MHD'63.56	416630105000	63	56	41	M24	2.7	
50	DIN2080-A50 MHD'80.60	416800105000	80	60	45	M24	3.2	

### DIN 228/A 2207

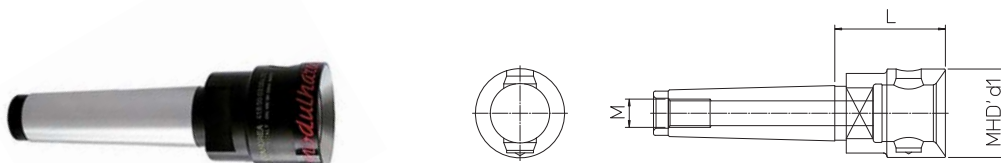

MORSE	REF.	CODE	MHD' d1	L	M	kg
4	MORSE4-A MHD'50.63	416500300400	50	63	M16	0.9
4 SIP	MORSE4-A SIP MHD'50.63	416500300401	50	63	M14	0.9

### DIN 228/B 1806

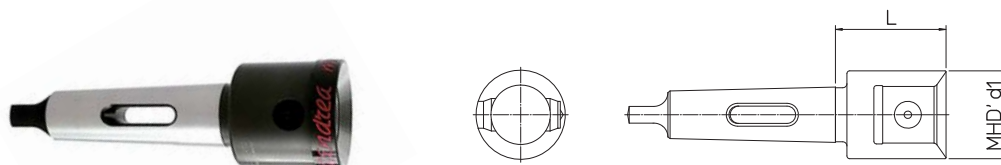

MORSE	REF.	CODE	MHD' d1	L	kg
4	MORSE4-B MHD'50.56	416500200400	50	56	0.9
5	MORSE5-B MHD'63.65	416630200500	63	65	1.5

## BR BARRE IN ACCIAIO



fig.1

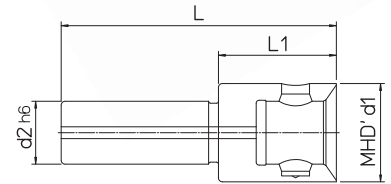
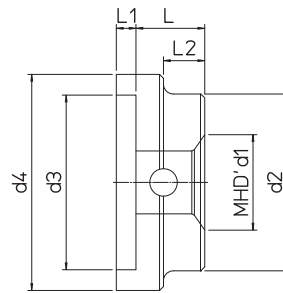
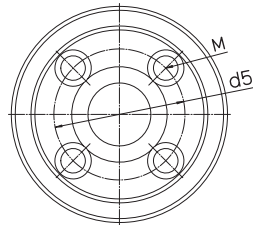

fig.2

REF.	CODE	MHD' d1	L	L1	d2	kg	fig.
BR 16/16.100	657081601001	16	100		16	0.15	1
BR 20/20.125	657082001251	20	125		20	0.3	1
BR 25/32.35	416320802500	32	100	35	25	0.7	2
BR 32/50.60	416500803200	50	140	60	32	1	2

## DIN 2079



REF.	CODE	MHD' d1	d2	d3	d4	d5	L	L1	L2	M	kg	
DIN 2079-40.50	416502004000 •	50	90	88.89	110	66.7	35	10	21	M12	1.8	• Salvo disponibilità magazzino
DIN 2079-40.63	416632004000 •	63	90	88.89	110	66.7	47	10	31	M12	2	
DIN 2079-50.63	416632005000 •	63	135	128.57	150	101.6	45	12	31	M16	5.4	
DIN 2079-50.80	416802005000 •	80	135	128.57	150	101.6	50	12	36	M16	5.3	
DIN 2079-50.110	416912005000 •	110	135	128.57	150	101.6	112	12	98	M16	8.4	
DIN 2079-50.140	416942005000 •	140	140	128.57	150	101.6	122	12	108	M16	9.5	

## BMD BARRE IN METALLO DURO

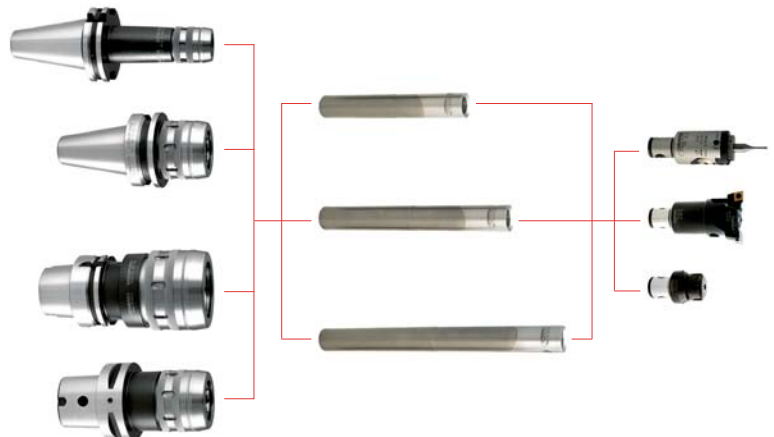
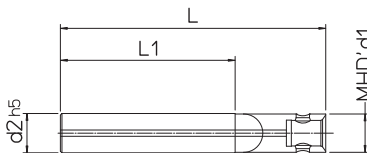

REF.	CODE	MHD' d1	d2	L	L1	kg
BMD 16/16.110	657081601105	16	16	110	70	0.3
BMD 16/16.140	657081601405	16	16	140	100	0.4
BMD 16/16.170	657081601705	16	16	170	130	0.5
BMD 20/20.135	657082001355	20	20	135	89	0.6
BMD 20/20.170	657082001705	20	20	170	124	0.75
BMD 20/20.210	657082002105	20	20	210	164	0.9
BMD 25/25.160	657082501605	25	25	160	107	1
BMD 25/25.205	657082502055	25	25	205	152	1.3
BMD 25/25.255	657082502555	25	25	255	202	1.6
BMD 32/32.195	657083201955	32	32	195	130	2.1
BMD 32/32.250	657083202505	32	32	250	185	2.8
BMD 32/32.315	657083203155	32	32	315	250	3.5

PR

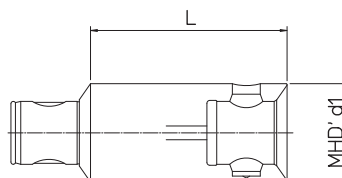

REF.	CODE	MHD' d1	L	kg	
PR 14.25	656901400250	14	25	0.02	• Salvo disponibilità magazzino
PR 16.25	656901600250	16	25	0.04	
PR 20.32	656902000320	20	32	0.07	
PR 25.25	656902500250	25	25	0.09	
PR 25.40	656902500400	25	40	0.15	
PR 32.32	656903200320	32	32	0.2	
PR 32.50	656903200500	32	50	0.3	
PR 40.40	656904000400	40	40	0.4	
PR 40.63	656904000630	40	63	0.6	
PR 50.50	656905000500	50	50	0.7	
PR 50.80	656905000800	50	80	1.1	
PR 50.100	656905001000	50	100	1.5	
PR 63.63	656906300630	63	63	1.4	
PR 63.100	656906301000	63	100	2.2	
PR 63.125	656906301250	63	125	2.9	
PR 80.80	656908000800	80	80	3	
PR 80.125	656908001250	80	125	4.6	
PR 80.160	656908001600	80	160	6.1	
PR 110.140	656911001400	110	140	13.5	
PR 110.200	656911002000	110	200	14.3	
PR 140.140	656914001400 •	140	140	24	
PR 140.250	656914002500 •	140	250	28.5	

RAV ANTIVIBRANTI

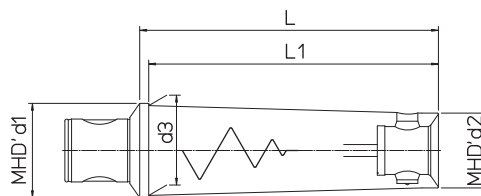

REF.	CODE	MHD' d1	MHD' d2	d3	L	L1	kg
RAV 50/16.74	657005000165	50	16	17.5	74	65	0.4
RAV 50/20.93	657005000205	50	20	21.5	93	85	0.5
RAV 50/25.117	657005000255	50	25	27	117	110	0.8
RAV 50/32.144	657005000325	50	32	35	144	138	1.4
RAV 50/40.176	657005000405	50	40	47	176	170	2.5
RAV 63/50.220	657006300505	63	50	60	220	214	5.6
RAV 80/63.280	657008000635	80	63	77	280	272	10.6

RD

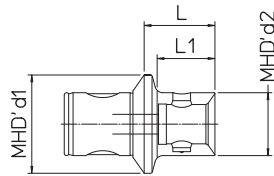

REF.	CODE	MHD' d1	MHD' d2	L	L1	kg	
RD 16/14.25	657001600140	16	14	25	19.5	0.02	
RD 20/14.20	657002000140 •	20	14	20	14.5	0.03	
RD 20/16.20	657002000160	20	16	20	16	0.05	
RD 25/14.20	657002500140 •	25	14	20	13.5	0.06	
RD 25/16.20	657002500160	25	16	20	15	0.07	
RD 25/20.25	657002500200	25	20	25	20	0.08	
RD 32/14.25	657003200140 •	32	14	25	17.5	0.08	
RD 32/16.24	657003200160	32	16	24	18	0.10	
RD 32/20.25	657003200200	32	20	25	20	0.12	
RD 32/25.28	657003200250	32	25	28	23	0.14	
RD 40/14.25	657004000140 •	40	14	25	16.5	0.10	
RD 40/16.24	657004000160	40	16	24	17	0.18	
RD 40/20.26	657004000200	40	20	26	20	0.2	
RD 40/25.28	657004000250	40	25	28	22	0.25	
RD 40/32.32	657004000320	40	32	32	27	0.3	
RD 50/14.25	657005000140 •	50	14	25	14.5	0.25	
RD 50/14.40	657005000142	50	14	40	29.5	0.1	
RD 50/16.24	657005000160	50	16	24	15	0.34	
RD 50/20.26	657005000200	50	20	26	18	0.37	
RD 50/25.28	657005000250	50	25	28	21	0.4	
RD 50/32.32	657005000320	50	32	32	25	0.45	
RD 50/40.36	657005000400	50	40	36	30	0.5	
RD 63/50.40	657006300500	63	50	40	34	0.9	
RD 80/50.45	657008000500	80	50	45	36	1.2	
RD 80/63.60	657008000630	80	63	60	52	1.7	
RD 110/80.70	657011000800	110	80	70	52	6	
RD 140/80.70	657014000800 •	140	80	70	49	7.8	

• Salvo disponibilità magazzino

RD

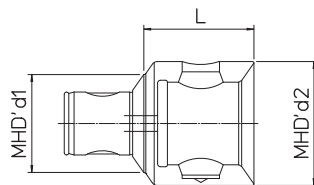

REF.	CODE	MHD' d1	MHD' d2	L	L1	kg
RD 50/63.56	657005000630	50	63	56	1.1	

RD

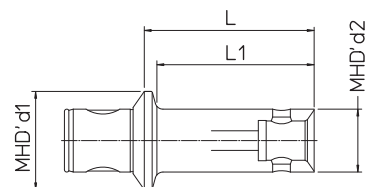

REF.	CODE	MHD' d1	MHD' d2	L	L1	kg
RD 50/16.40	657005000162	50	16	40	32	0.2
RD 50/16.74	657005000163	50	16	74	65	0.25
RD 50/20.70	657005000202	50	20	70	62	0.3
RD 50/20.93	657005000203	50	20	93	85	0.35
RD 50/25.87	657005000252	50	25	87	80	0.6
RD 50/25.117	657005000253	50	25	117	110	0.65
RD 50/32.87	657005000322	50	32	87	80	0.75
RD 50/32.144	657005000323	50	32	144	137	1
RD 50/40.87	657005000402	50	40	87	80	0.9
RD 50/40.176	657005000403	50	40	176	170	1.8



## TS 16 ~ 80 Ø 18 ~ 200

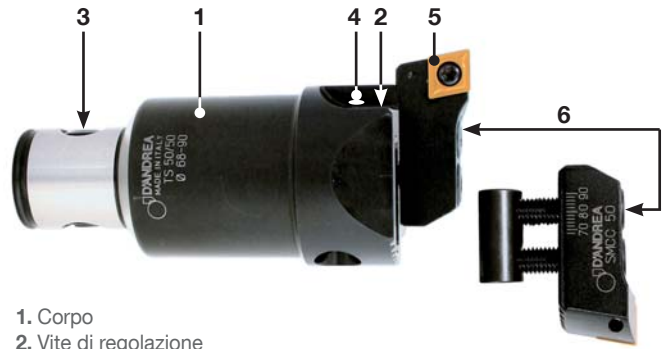

1. Corpo
2. Vite di regolazione
3. Perno radiale espandibile
4. Fori uscita refrigerante Max BAR 40
5. Seggio portainseri
6. Viti bloccaggio utensile

**TS** Testine di sgrossatura semplici ed estremamente rigide grazie alle superfici di contatto dentellate tra il corpo testa e i seggi portainserito. La distanza costante tra la vite di serraggio del seggio ed il tagliente garantisce la stabilità del sistema.

## TS 16/16 Ø 18 ~ 22

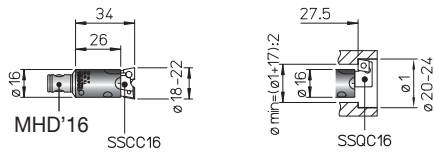

## TS 20/20 Ø 22 ~ 28



## TS 25/25 Ø 28 ~ 38

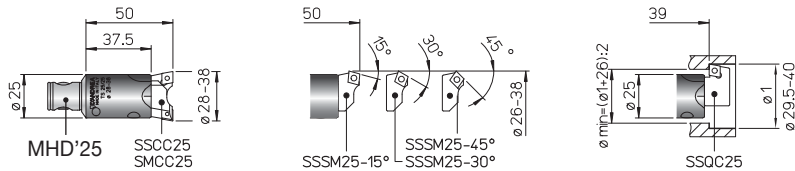

## TS 32/32 Ø 35.5 ~ 50

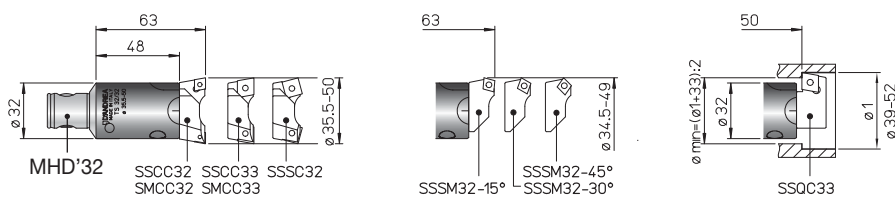

REF.	CODE	Ø	Kg.
TS 16/16	455501600340	18 ~ 22	0.05
TS 20/20	455502000400	22 ~ 28	0.09
TS 25/25	455502500500	28 ~ 38	0.2
TS 32/32	455503200630	35.5 ~ 50	0.35
TS 40/40	455504000800	50 ~ 68	0.7
TS 50/50	455305001000	68 ~ 90	1.5
TS 50/63	455306300800	90 ~ 120	2
TS 63/63	455406301250	90 ~ 120	3
TS 80/80	455408001400	120 ~ 160	5.3

## TS 40/40 $\varnothing 50 \sim 68$

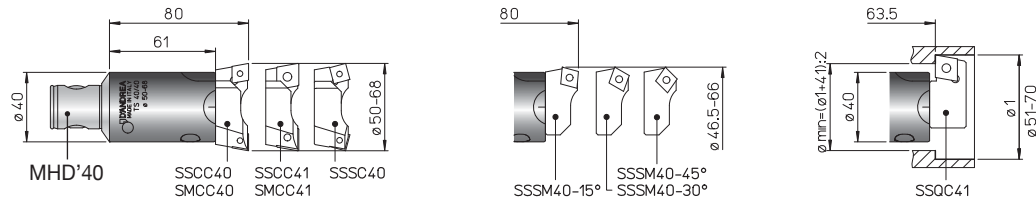

## TS 50/50 $\varnothing 68 \sim 90$

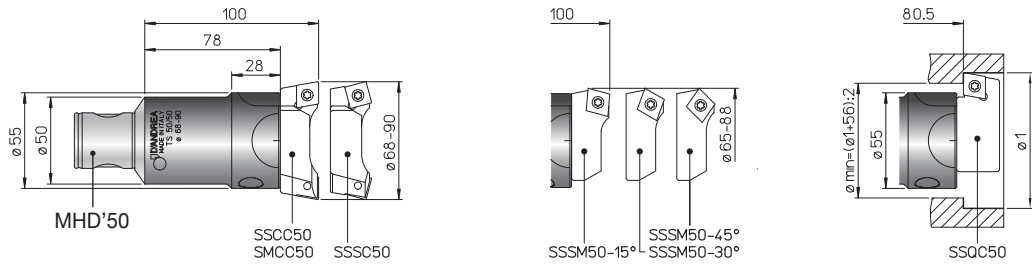

## TS 50/63 $\varnothing 90 \sim 120$

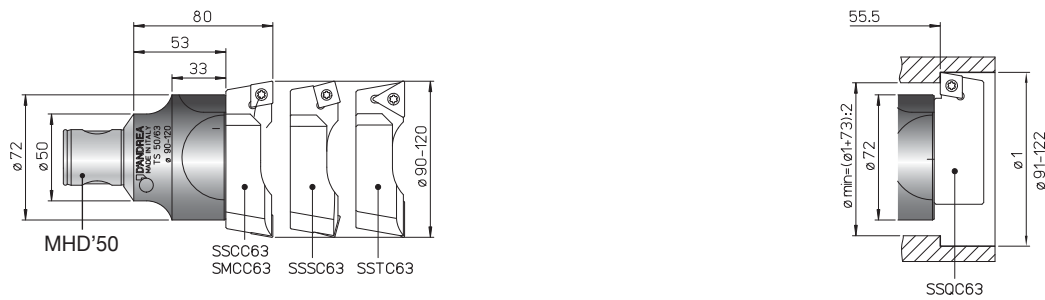

## TS 63/63 $\varnothing 90 \sim 120$

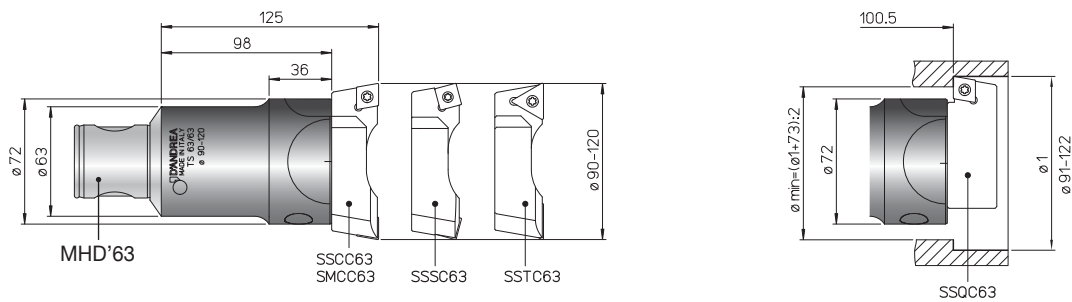

## TS 80/80 $\varnothing 120 \sim 160$

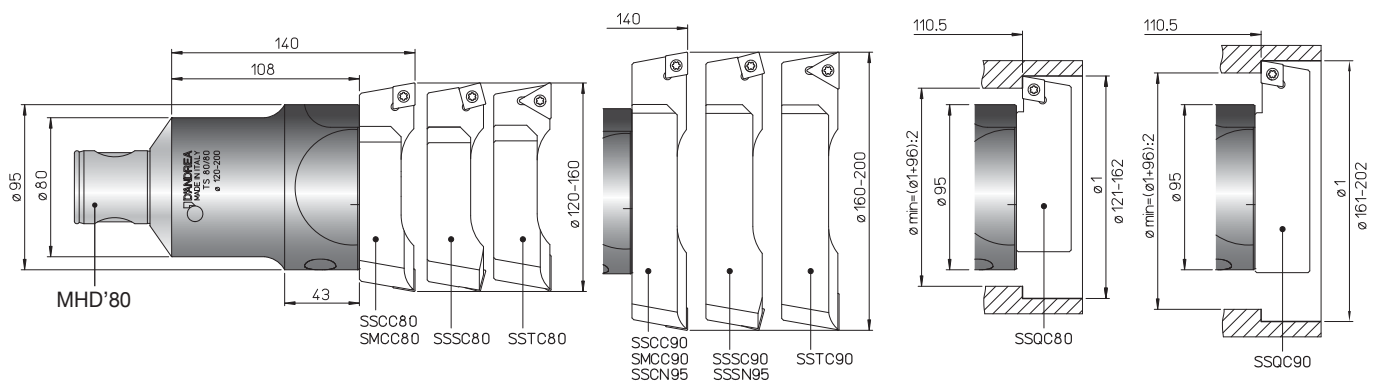

## IMPIEGO

Operazioni di sgrossatura e semi-finitura. La regolazione dei taglienti va eseguita su un banco di presetting e le testine TS possono essere utilizzate in tre diverse configurazioni.

## ATTENZIONE

Per lavorare con un solo tagliente o con differenti diametri di taglio, dimezzare l'avanzamento indicato in tabella vedere pag. 92

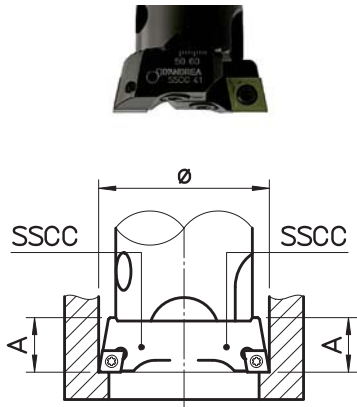

fig.1

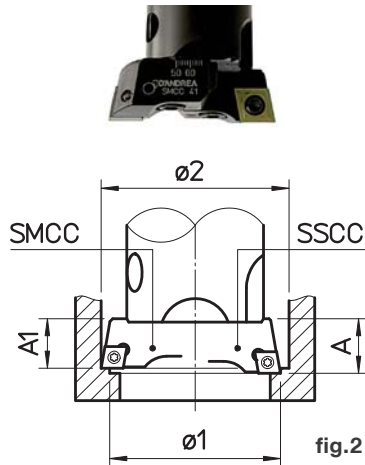

fig.2

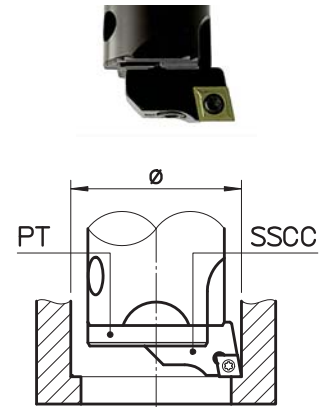
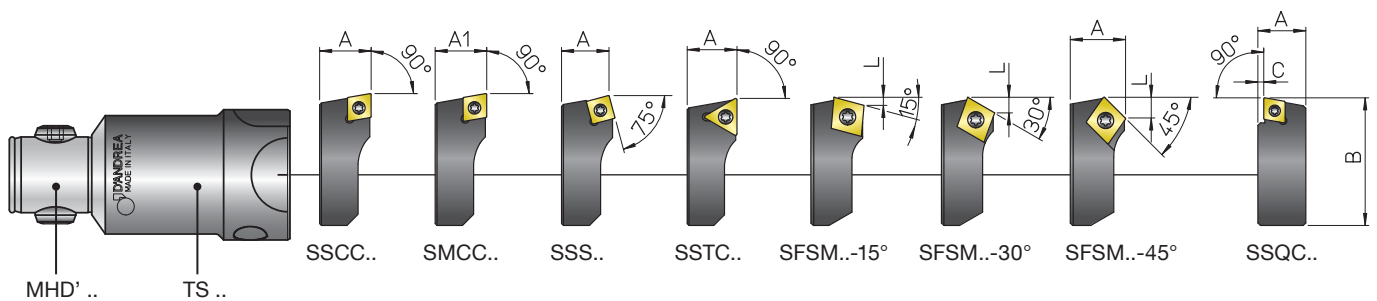

fig.3

**fig.1** con due seggi SSCC allineati e sullo stesso diametro per operazioni di sgrossatura con forti avanzamenti.

**fig. 2** con un seggio SSCC ed un seggio SMCC disallineato e su un diverso diametro per operazioni di sgrossatura con alte profondità di passata.

**fig.3** con un solo seggio per operazioni di sgrossatura leggera o semifinitura. Necessario il montaggio della piastrina PT per proteggere la superficie di accoppiamento.



## PT PROTEZIONI MILLERIGHE

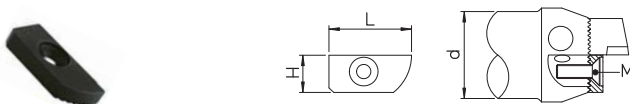

REF.	CODE	d	H	L	M
PT 16	384765000160	16	7	14	M 3x12
PT 20	384765000200	20	8.5	17	M 4x14
PT 25	384765000250	25	10.2	21	M 4x16
PT 32	384765000320	32	13.9	28	M 5x20
PT 40	384765000400	40	17.4	35	M 6x25
PT 50	384765000500	50	21.4	47.5	M 8x25
PT 63	384765000630	63	26.4	62	M 10x30
PT 80	384765000800	80	33.9	82.5	M 12x35

**SEGGI** SSCC.. - SSCN.. - SMCC.. - SSSC.. - SSSN.. - SSTC.. - SFSM.. - SSQC..



SSCC.. - SSCN / SMCC..



SSSC.. / SSSN..



SSTC..



SSSM..



SSQC..

REF.	CODE	A	A1	B	C	L						Kg.
<b>SSCC 16</b>	470500516201	8		15				CCMT 0602..		TS 25	TORX T08	0.003
<b>SSCC 20</b>	470500520201	9.5		19				CCMT 0602..		TS 25	TORX T08	0.006
<b>SSCC 25</b>	470500525201	12.5		23				CCMT 0602..		TS 25	TORX T08	0.01
<b>SSCC 32</b>	470500532201	15		32				CCMT 0602..		TS 25	TORX T08	0.02
<b>SSCC 33</b>	470500532204	15		32				CCMT 09T3..		TS 4	TORX T15	0.025
<b>SSCC 40</b>	470500540201	19		40				CCMT 09T3..		TS 4	TORX T15	0.06
<b>SSCC 41</b>	470500540204	19		40				CCMT 1204..		TS5	TORX T25	0.06
<b>SSCC 50</b>	470500550204	22		54				CCMT 1204..		TS5	TORX T25	0.1
<b>SSCC 63</b>	470500563201	27		70.5				CCMT 1204..		TS5	TORX T25	0.2
<b>SSCC 80</b>	470500580201	32		94.5				CCMT 1204..		TS5	TORX T25	0.5
<b>SSCC 90</b>	470500590201	32		130				CCMT 1204..		TS5	TORX T25	0.7
<b>SSCN 95</b>	470500595201	40		130				CNM. 1906..		<b>p. 89</b>	<b>p. 89</b>	0.9
<b>SMCC 25</b>	470500525203	12.3		23				CCMT 0602..		TS 25	TORX T08	0.01
<b>SMCC 32</b>	470500532203	14.8		32				CCMT 0602..		TS 25	TORX T08	0.02
<b>SMCC 33</b>	470500532205	14.8		32				CCMT 09T3..		TS 4	TORX T15	0.025
<b>SMCC 40</b>	470500540203	18.7		40				CCMT 09T3..		TS 4	TORX T15	0.06
<b>SMCC 41</b>	470500540205	18.7		40				CCMT 1204..		TS 5	TORX T25	0.06
<b>SMCC 50</b>	470500550205	21.7		54				CCMT 1204..		TS 5	TORX T25	0.1
<b>SMCC 63</b>	470500563203	26.7		70.5				CCMT 1204..		TS 5	TORX T25	0.2
<b>SMCC 80</b>	470500580203	31.7		94.5				CCMT 1204..		TS 5	TORX T25	0.5
<b>SMCC 90</b>	470500590203	31.7		130				CCMT 0602..		TS 25	TORX T08	0.7
<b>SSSC 32</b>	470500532202	15		32					SCMT 09T3..	TS 4	TORX T15	0.02
<b>SSSC 40</b>	470500540202	19		40					SCMT 09T3..	TS 4	TORX T15	0.06
<b>SSSC 50</b>	470500550202	20.5		54					SCMT 1204..	TS 5	TORX T25	0.1
<b>SSSC 63</b>	470500563202	27		70.5					SCMT 1204..	TS 5	TORX T25	0.2
<b>SSSC 80</b>	470500580202	32		94.5					SCMT 1204..	TS 5	TORX T25	0.5
<b>SSSC 90</b>	470500590202	32		130					SCMT 1204..	TS 5	TORX T25	0.7
<b>SSSN 95</b>	470500595202	40		130					SNM. 1906..	<b>p. 89</b>	<b>p. 89</b>	0.9
<b>SSTC 63</b>	470500563206	27		70.5			TCMT 2204..			TS 5	TORX T25	0.2
<b>SSTC 80</b>	470500580206	32		94.5			TCMT 2204..			TS 5	TORX T25	0.5
<b>SSTC 90</b>	470500590206	32		130			TCMT 2204..			TS 5	TORX T25	0.7
<b>SSSM 25-15°</b>	470500525211	12.5		23	1.6			CCMT 0602..		TS 25	TORX T08	0.01
<b>SSSM 25-30°</b>	470500525213	12.5		23	3			CCMT 0602..		TS 25	TORX T08	0.01
<b>SSSM 25-45°</b>	470500525215	12.5		23	4.3			CCMT 0602..		TS 25	TORX T08	0.01
<b>SSSM 32-15°</b>	470500532211	15		31	1.6			CCMT 0602..		TS 25	TORX T08	0.025
<b>SSSM 32-30°</b>	470500532213	15		31	3			CCMT 0602..		TS 25	TORX T08	0.025
<b>SSSM 32-45°</b>	470500532215	15		31	4.3			CCMT 0602..		TS 25	TORX T08	0.025
<b>SSSM 40-15°</b>	470500540211	19		39	2.4			CCMT 09T3..		TS 4	TORX T15	0.06
<b>SSSM 40-30°</b>	470500540213	19		39	4.6			CCMT 09T3..		TS 4	TORX T15	0.06
<b>SSSM 40-45°</b>	470500540215	19		39	6.5			CCMT 09T3..		TS 4	TORX T15	0.06
<b>SSSM 50-15°</b>	470500550211	22		53	3.2			CCMT 1204..		TS 5	TORX T25	0.1
<b>SSSM 50-30°</b>	470500550213	22		53	6.2			CCMT 1204..		TS 5	TORX T25	0.1
<b>SSSM 50-45°</b>	470500550215	22		53	8.8			CCMT 1204..		TS 5	TORX T25	0.1
<b>SSQC 16</b>	470500516261	10		16	2			CCMT 0602..		TS 25	TORX T08	0.005
<b>SSQC 20</b>	470500520261	11		19.5	1.5			CCMT 0602..		TS 25	TORX T08	0.008
<b>SSQC 25</b>	470500525261	14.5		24	2.5			CCMT 0602..		TS 25	TORX T08	0.02
<b>SSQC 33</b>	470500533261	17		32	3			CCMT 09T3..		TS 4	TORX T15	0.03
<b>SSQC 41</b>	470500541261	21		42	3.5			CCMT 1204..		TS 5	TORX T25	0.08
<b>SSQC 50</b>	470500550261	24.5		57	3.5			CCMT 1204..		TS 5	TORX T25	0.15
<b>SSQC 63</b>	470500563261	28.5		76	3.5			CCMT 1204..		TS 5	TORX T25	0.3
<b>SSQC 80</b>	470500580261	31.5		101	3.5			CCMT 1204..		TS 5	TORX T25	0.6
<b>SSQC 90</b>	470500590261	31.5		122	3.5			CCMT 1204..		TS 5	TORX T25	0.8



## TRD 25-80 Ø 28 ~ 160

TRD 25 - 32	RPM 10.000
TRD 40 - 50	RPM 8.000
TRD 63	RPM 6.000
TRD 80	RPM 5.000

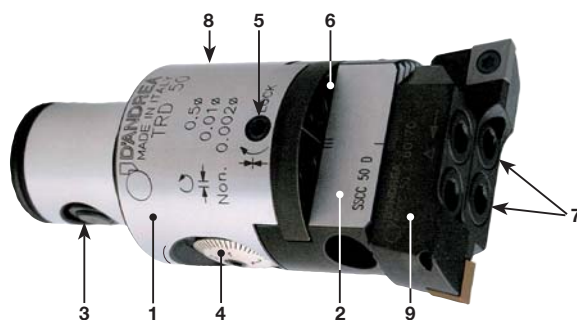

## CENTESIMALE

10 µm

1. Corpo
2. Slitta portautensili
3. Perno radiale espandibile
4. Nonio
5. Vite bloccaggio slitta
6. Uscita refrigerante **Max BAR 40**
7. Viti bloccaggio utensile
8. Oliatore
9. Sedgio portainseriti

Le testine bitaglianti **TRD** consentono lavorazioni combinate di sgrossatura e finitura con grado di precisione **IT7**.

Le superfici dentellate di contatto tra i sedgi e la slitta portautensile garantiscono rigidità e la sensibilità di regolazione di 5 micron sul raggio è facilmente leggibile sul nonio ed eseguibile anche in macchina.

## TRM 16-125 Ø 2.5 ~ 500

TRM 16 - 20	RPM 12.000	TRM 63	RPM 6.000
TRM 25 - 32	RPM 10.000	TRM 80	RPM 5.000
TRM 40 - 50	RPM 8.000	TRM 125	RPM 4.000



## MICROMETRICA

2 µm

1. Corpo
2. Slitta portautensili
3. Perno radiale espandibile
4. Nonio micrometrico
5. Vite bloccaggio slitta
6. Uscita refrigerante **Max BAR 40**
7. Viti bloccaggio utensili
8. Oliatore
9. Sedgio portainseriti
10. Porta utensile

Le testine **TRM** consentono lavorazioni di alta precisione e ottima finitura superficiale in tolleranze di grado **IT6**.

La sensibilità di regolazione di 1 micron sul raggio è facilmente leggibile sul nonio ed eseguibile anche in macchina. Le **TRM** sono rivestite con una protezione superficiale anticorrosiva.

## TRC 14-80 Ø 2.5 ~ 200

TRC 14 - 20	RPM 12.000
TRC 25 - 32	RPM 10.000
TRC 40 - 50	RPM 8.000
TRC 80	RPM 6.000
TRC 80	RPM 5.000

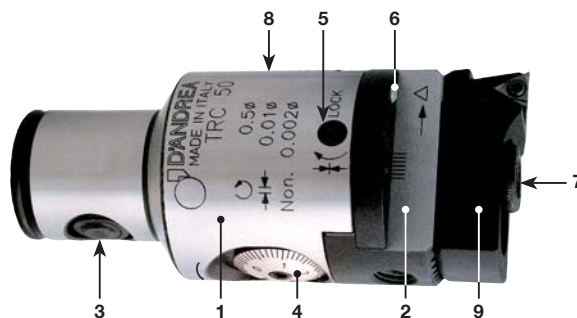

## CENTESIMALE

10 µm

1. Corpo
2. Slitta portautensili
3. Perno radiale espandibile
4. Nonio
5. Vite bloccaggio slitta
6. Uscita refrigerante **Max BAR 40**
7. Viti bloccaggio utensile
8. Oliatore
9. Sedgio portainseriti

Le testine **TRC** consentono lavorazioni di alta precisione e ottima finitura superficiale in tolleranze di grado **IT7**.

La sensibilità di regolazione di 5 micron sul raggio è facilmente leggibile sul nonio ed eseguibile anche in macchina.

## TRM HSB Ø 2.5 ~ 22

TRM 32 HSB RPM 20.000  
TRM 50 HSB RPM 20.000

## MICROMETRICA

2 µm

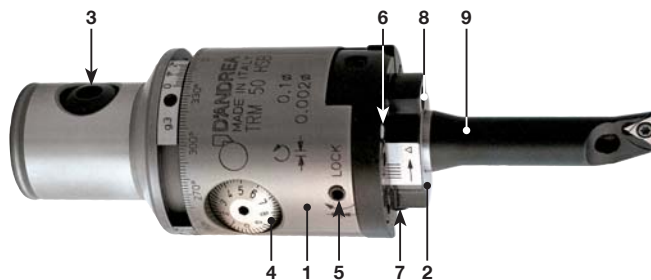

1. Corpo
2. Slitta portautensili
3. Perno radiale espandibile
4. Nonio micrometrico
5. Vite bloccaggio slitta
6. Uscita refrigerante Max BAR 40
7. Viti bloccaggio utensile
8. Oliatore
9. Utensile

Le testine **TRM HSB** sono bilanciabili e dedicate all'alta velocità. Consentono lavorazioni di alta precisione e ottima finitura superficiale in tolleranze di grado **IT6**.

La sensibilità di regolazione di 1 micron sul raggio è facilmente leggibile sul nonio ed eseguibile anche in macchina. Le **TRM HSB** sono rivestite con una protezione superficiale anticorrosiva.

## TRC HS Ø 2.5 ~ 22

TRC 32 HS RPM 12.000  
TRC 50 HS RPM 12.000

## CENTESIMALE

10 µm

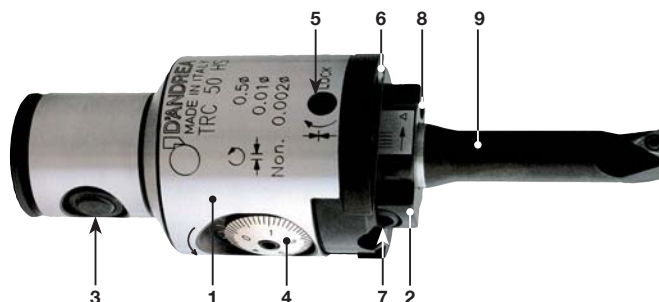

1. Corpo
2. Slitta portautensili
3. Perno radiale espandibile
4. Nonio
5. Vite bloccaggio slitta
6. Uscita refrigerante Max BAR 40
7. Viti bloccaggio utensile
8. Oliatore
9. Utensile

Le testine **TRC HS** sono bilanciate e dedicate all'alta velocità. Consentono lavorazioni di alta precisione e ottima finitura superficiale in tolleranze di grado **IT7**.

La sensibilità di regolazione di 5 micron sul raggio è facilmente leggibile sul nonio ed eseguibile anche in macchina.

## TRE 32-80 69K Ø 2.5 ~ 200

TRE 32 - 50 RPM 20.000  
TRE 63 - 80 RPM 12.000

## MICROMETRICA

2 µm

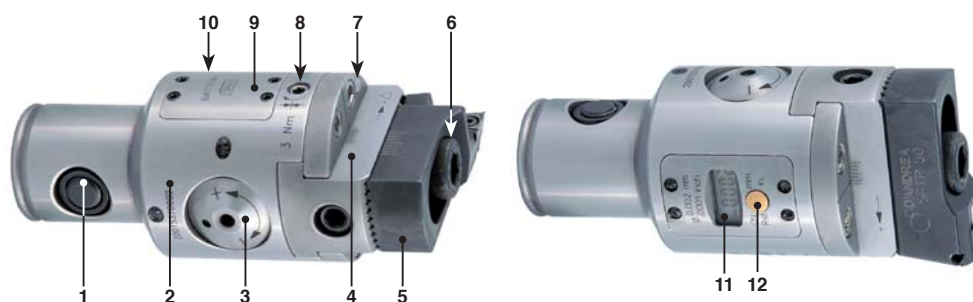

1. Perno radiale espandibile
2. Corpo
3. Vite di regolazione
4. Slitta portautensili
5. Seggio portainseriti
6. Vite bloccaggio utensili
7. Ugello uscita refrigerante Max BAR 40
8. Vite bloccaggio slitta
9. Coperchio vano pile
10. Oliatore
11. Display digitale
12. Pulsante di selezione

Le testine **TRE** consentono lavorazioni di alta precisione e ottima finitura superficiale in tolleranze di grado **IT6**. La sensibilità di regolazione di 1 micron sul raggio è veloce e precisa, facilmente visualizzabile sul display integrato.

Le **TRE** sono rivestite con una protezione superficiale anticorrosiva e resistenti alle infiltrazioni secondo il grado **IP69K**.

## TRD 25 ~ 80 Ø 28 ~ 160



REF.	CODE	Ø	Kg.
TRD 25	455022500571	28 ~ 36	0.2
TRD 32	455023200711	36 ~ 46	0.35
TRD 40	455024000901	46 ~ 60	0.7
TRD 50	455025000861	60 ~ 75	1.5
TRD 63	455026301081	75 ~ 95	2.7
TRD 80	455028001291	95 ~ 160	4.8

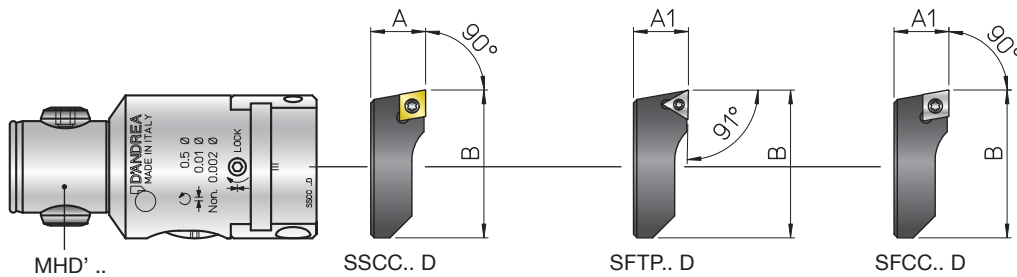

## SEGGI SSCC .. D - SFTP .. D - SFCC .. D



REF.	CODE	A	A1	B					Kg.
SSCC 25 D	470500525220	10		24			CCMT 0602..	TS 25 TORX T08	0.008
SSCC 32 D	470500532220	11.5		30			CCMT 0602..	TS 25 TORX T08	0.015
SSCC 40 D	470500540220	14		40			CCMT 09T3..	TS 4 TORX T15	0.03
SSCC 50 D	470500550220	19		54			CCMT 09T3..	TS 4 TORX T15	0.06
SSCC 63 D	470500563220	24.5		68			CCMT 09T3..	TS 4 TORX T15	0.15
SSCC 80 D	470500580220	29.5		87			CCMT 09T3..	TS 4 TORX T15	0.3
SSCC 85 D	470500585221	29.5		107.4			CCMT 09T3..	TS 4 TORX T15	0.4
SFTP 25 D	470500525030		9.8	24			TPGX 0902..	CS 250T TORX T08	0.008
SFTP 32 D	470500532030		11.3	30			TPGX 0902..	CS 250T TORX T08	0.015
SFTP 40 D	470500540030		13.8	40			TPGX 1103..	CS 300890T TORX T08	0.03
SFTP 50 D	470500550030		18.8	54			TPGX 1103..	CS 300890T TORX T08	0.06
SFTP 63 D	470500563030		24.3	68			TPGX 1103..	CS 300890T TORX T08	0.15
SFTP 80 D	470500580030		29.3	87			TPGX 1103..	CS 300890T TORX T08	0.3
SFTP 85 D	470500585031		29.3	107.4			TPGX 1103..	CS 300890T TORX T08	0.4
SFCC 25 D	470500525020		9.8	24			CCGT 0602..	TS 25 TORX T08	0.008
SFCC 32 D	470500532020		11.3	30			CCGT 0602..	TS 25 TORX T08	0.015
SFCC 40 D	470500540020		13.8	40			CCGT 09T3..	TS 4 TORX T15	0.03
SFCC 50 D	470500550020		18.8	54			CCGT 09T3..	TS 4 TORX T15	0.06
SFCC 63 D	470500563020		24.3	68			CCGT 09T3..	TS 4 TORX T15	0.15
SFCC 80 D	470500580020		29.3	87			CCGT 09T3..	TS 4 TORX T15	0.3
SFCC 85 D	470500585021		29.3	107.4			CCGT 09T3..	TS 4 TORX T15	0.4

## TRD 25 $\varnothing 28 \sim 36$

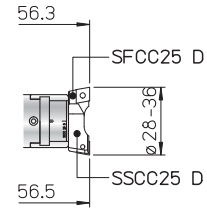
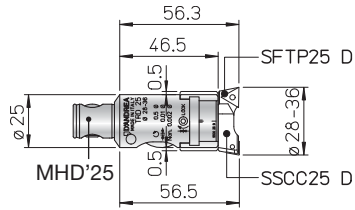

## TRD 32 $\varnothing 36 \sim 46$

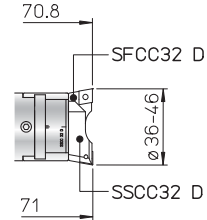
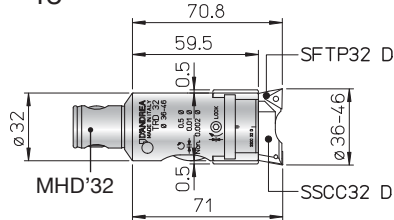

## TRD 40 $\varnothing 46 \sim 60$

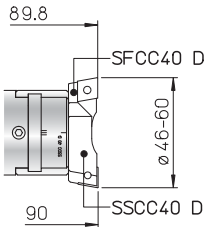
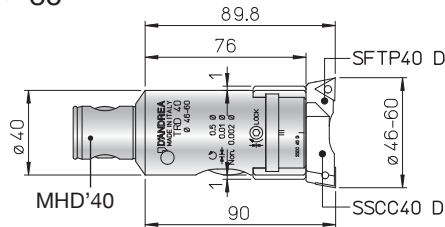

## TRD 50 $\varnothing 60 \sim 75$

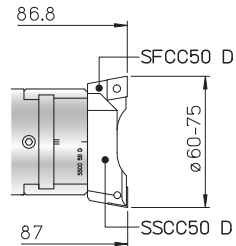
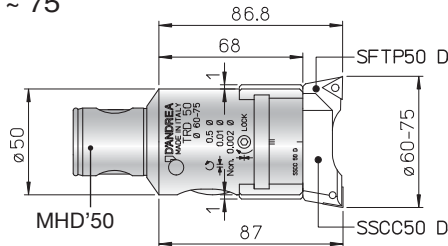

## TRD 63 $\varnothing 75 \sim 95$

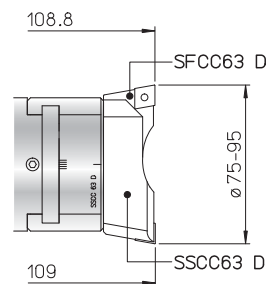
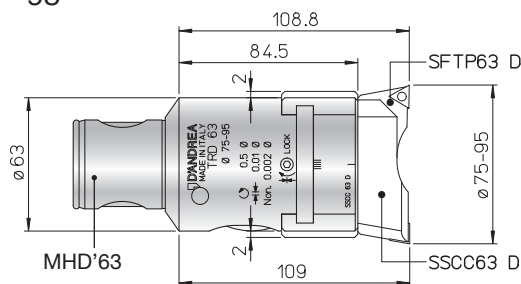

## TRD 80 $\varnothing 95 \sim 160$

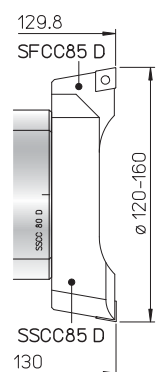
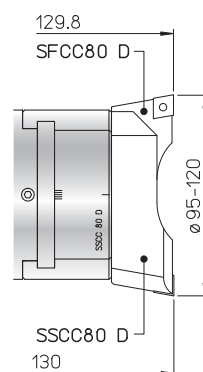
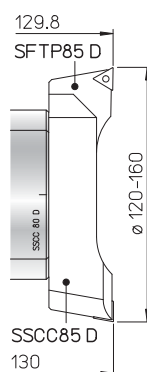
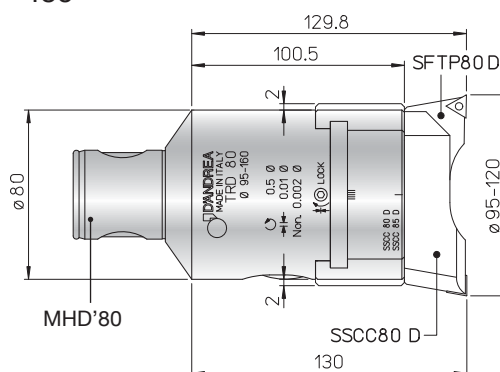

## TRM 16 ~ 40 Ø 18 ~ 63



REF.	CODE	Ø	Kg.
TRM 16	455001600341	18 ~ 23	0.05
TRM 20	455002000401	22 ~ 29	0.1
TRM 25	455002500500	28 ~ 38	0.2
TRM 32	455003200630	35.5 ~ 51.5	0.35
TRM 40	455004000800	48 ~ 63	0.7

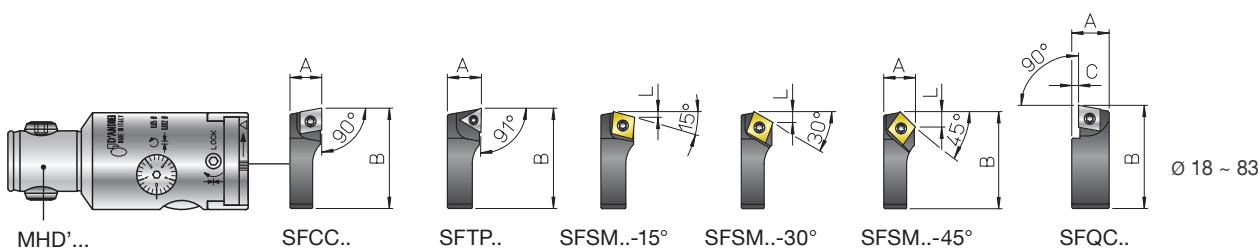

## SEGGI SFCC .. - SFTP .. - SFSM .. - SFQC ..



REF.	CODE	A	B	C	L					Kg.
SFCC 16	470500516002	8	17			CCGT 0602..		TS 25	TORX T08	0.003
SFCC 20	470500520002	8.5	21			CCGT 0602..		TS 25	TORX T08	0.005
SFCC 25	470500525002	10	26.5			CCGT 0602..		TS 25	TORX T08	0.01
SFCC 32	470500532002	11.5	34.5			CCGT 0602..		TS 25	TORX T08	0.02
SFCC 40	470500540002	14	44			CCGT 09T3..		TS 4	TORX T15	0.04
SFTP 25	470500525001	10	26.5				TPGX 0902..	CS 250T	TORX T08	0.01
SFTP 32	470500532001	11.5	34.5				TPGX 0902..	CS 250T	TORX T08	0.02
SFTP 40	470500540001	14	44				TPGX 1103..	CS 300890T	TORX T08	0.04
SFQC 16	470500516062	10	18	2		CCMT 0602..		TS 25	TORX T08	0.005
SFQC 20	470500520062	10.5	22.5	2		CCMT 0602..		TS 25	TORX T08	0.008
SFQC 25	470500525062	12	28.5	2.5		CCMT 0602..		TS 25	TORX T08	0.01
SFQC 32	470500532062	13.5	35.5	2.5		CCMT 0602..		TS 25	TORX T08	0.03
SFQC 40	470500540062	16.5	46	3		CCMT 09T3..		TS 4	TORXT15	0.06
SFSM 25-15°	470500525011	10	25.5		1.6	CCMT 0602..		TS 25	TORX T08	0.01
SFSM 25-30°	470500525013	10	25.5		3	CCMT 0602..		TS 25	TORX T08	0.01
SFSM 25-45°	470500525015	10	25.5		4.3	CCMT 0602..		TS 25	TORX T08	0.01
SFSM 32-15°	470500532011	11.5	33.5		1.6	CCMT 0602..		TS 25	TORX T08	0.02
SFSM 32-30°	470500532013	11.5	33.5		3	CCMT 0602..		TS 25	TORX T08	0.02
SFSM 32-45°	470500532015	11.5	33.5		4.3	CCMT 0602..		TS 25	TORX T08	0.02
SFSM 40-15°	470500540011	14	42.5		2.4	CCMT 09T3..		TS 4	TORXT15	0.03
SFSM 40-30°	470500540013	14	42.5		4.6	CCMT 09T3..		TS 4	TORXT15	0.03
SFSM 40-45°	470500540015	14	42.5		6.6	CCMT 09T3..		TS 4	TORXT15	0.03



## TRM 16 Ø 18 ~ 23

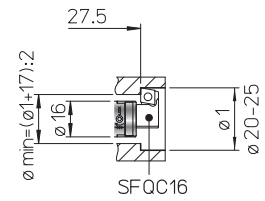
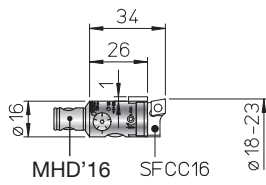

## TRM 20 Ø 22 ~ 29

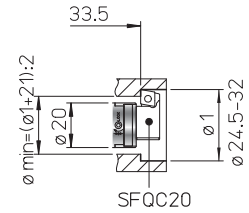
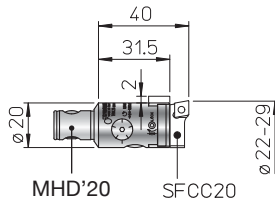

## TRM 25 Ø 28 ~ 38

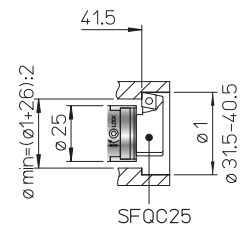
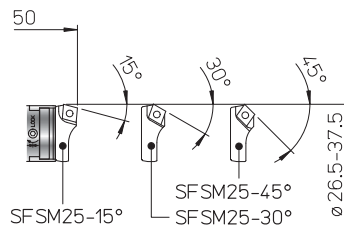
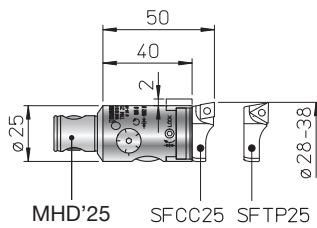

## TRM 32 Ø 35.5 ~ 51.5

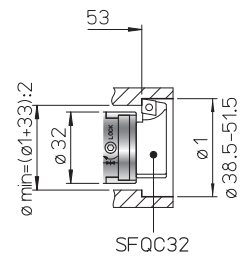
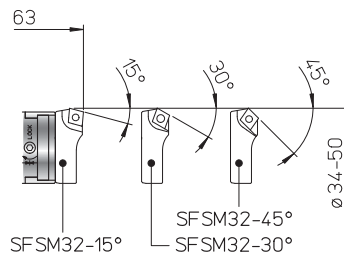
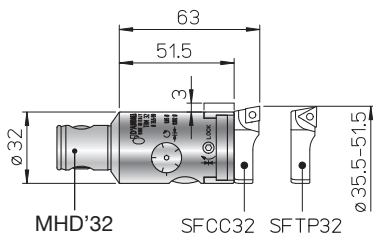

## TRM 40 Ø 48 ~ 63

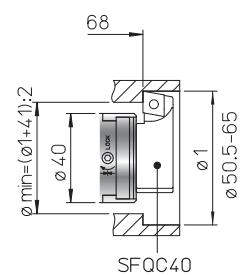
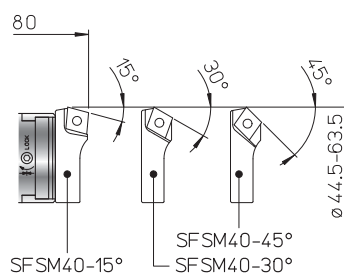
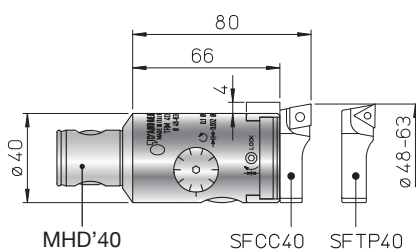

## TRM 50 Ø 2.5 ~ 108

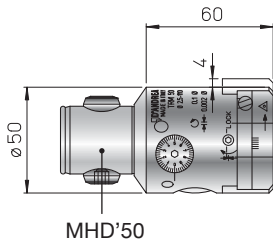

REF.	CODE	Kg.
TRM 50	455005000500	1
RDC D08.16	200560116082	0.02
P25.63 TR..	435116250631	0.5
P25.105 TR..	435116251051	0.8
PS 31.24 TR..50	433024140751	0.19
CW 32	392011003201	0.07

### Utensili

### Utensili antivibranti

### Utensili in metallo duro

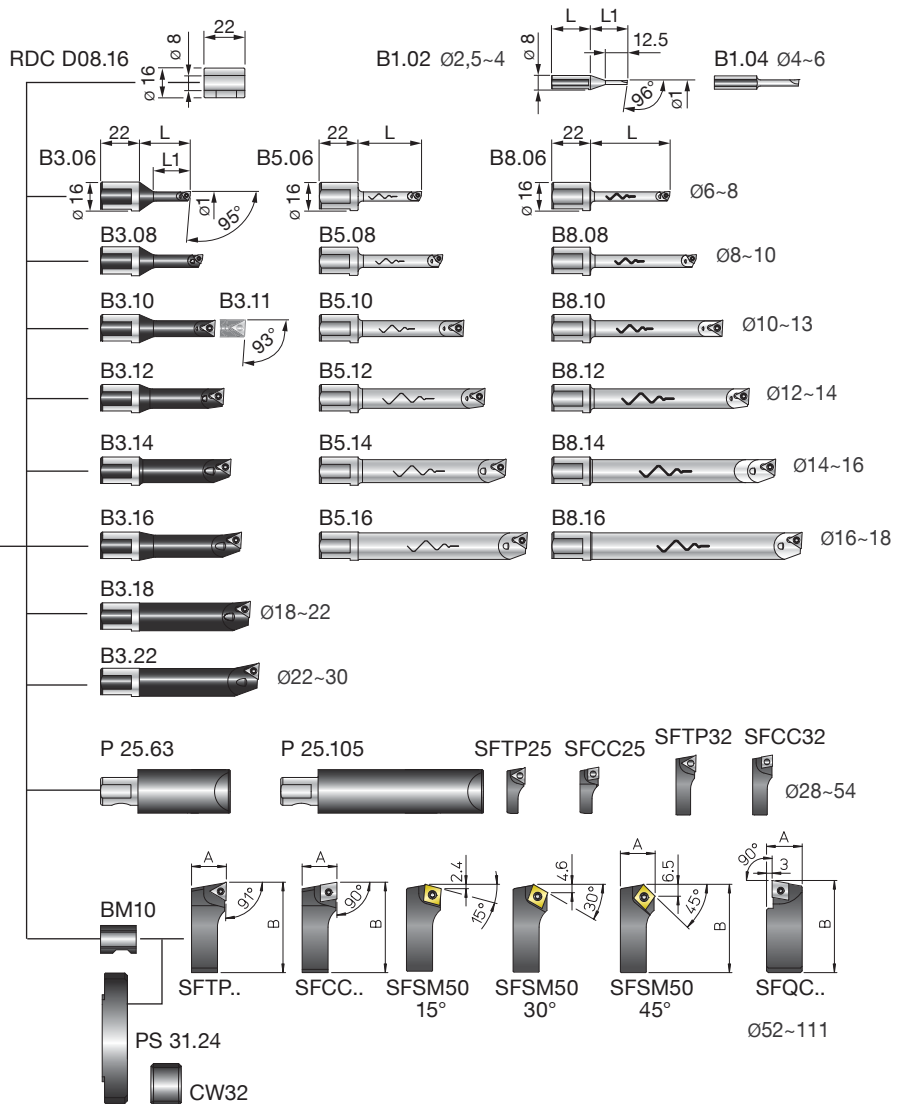

## KIT K01 Ø 6 ~ 108

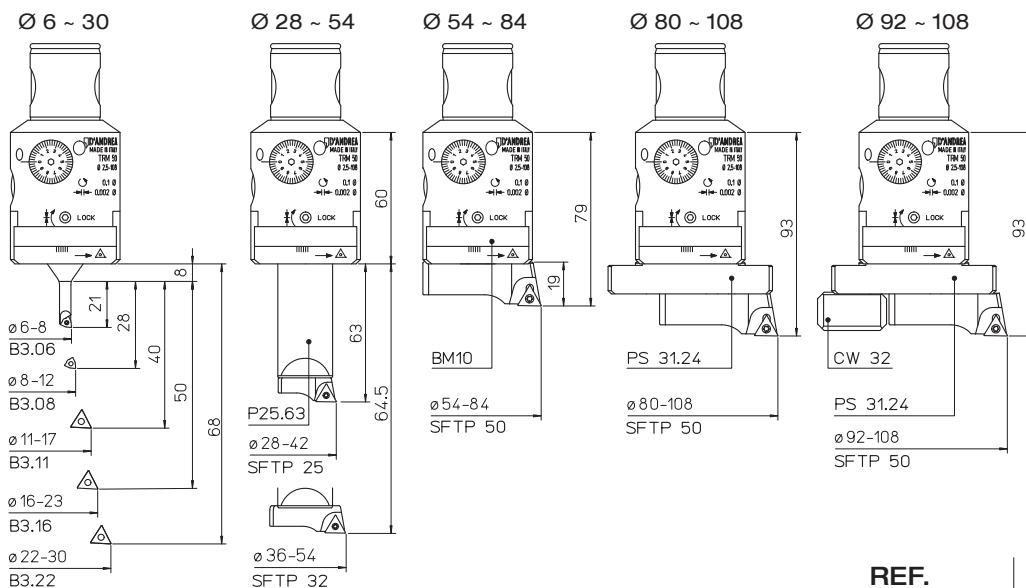

- 1 TRM 50
- 1 BM10
- 1 P25.63
- 1 PS 31.24
- 1 CW 32
- 1 B3.06
- 1 B3.08
- 1 B3.11
- 1 B3.16
- 1 B3.22
- 1 SFTP25
- 1 SFTP32
- 1 SFTP50
- 5 TPGX 090202L DC100
- 1 TPGX 110302L DC100
- 2 WCGT 020102L DC100

REF.	CODE	Ø	Kg.
KIT K01 TRM50	655005010501	6 ~ 108	3.1

## P 25 Ø 28 ~ 54

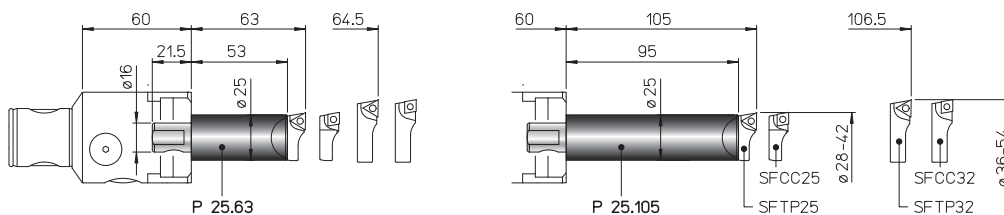

## PS 31.24 Ø 54 ~ 108

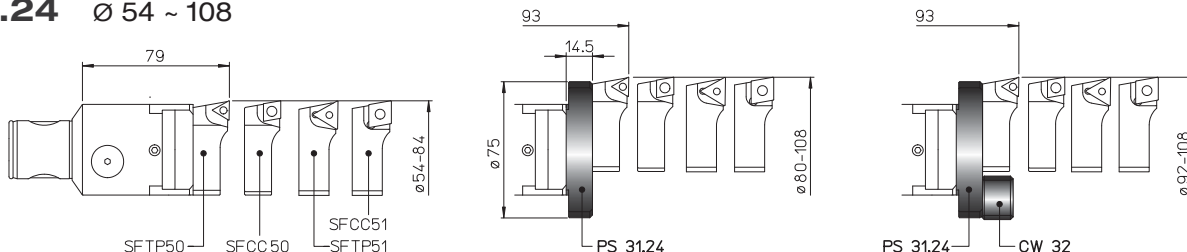

## PS 31.24 Ø 52 ~ 111

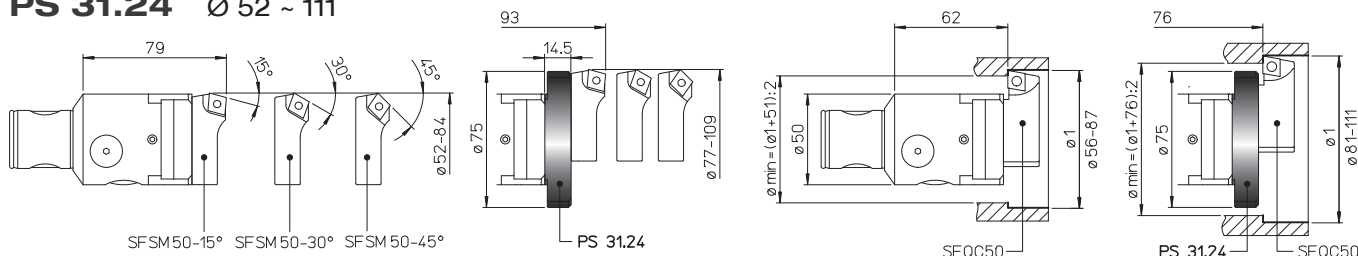

REF.	CODE	Ø1	L	L1	A	B	⊖	⊖	⊖	⊖	⊖	Kg.
SFTP 25	470500525001				10	26.5		TPGX 0902..		CS 250T	TORX T08	0.01
SFTP 32	470500532001				11.5	34.5		TPGX 0902..		CS 250T	TORX T08	0.02
SFTP 50	470500550001				19	52		TPGX 1103..		CS 300890T	TORX T08	0.08
SFTP 51	470500550003				21	52		TCMT 16T3..		TS 4	TORX T15	0.09
SFCC 25	470500525002				10	26.5		CCGT 0602..		TS 25	TORX T08	0.01
SFCC 32	470500532002				11.5	34.5		CCGT 0602..		TS 25	TORX T08	0.02
SFCC 50	470500550002				19	52		CCGT 09T3..		TS 4	TORX T15	0.08
SFCC 51	470500550004				21	52		CCMT 1204..		TS 5	TORX T25	0.09
SFQC 50	470500550062				20.5	53		CCMT 09T3..		TS 4	TORXT15	0.1
SFSM 50-15°	470500550011				19	50.5		CCMT 09T3..		TS 4	TORXT15	0.07
SFSM 50-30°	470500550013				19	50.5		CCMT 09T3..		TS 4	TORXT15	0.07
SFSM 50-45°	470500550015				19	50.5		CCMT 09T3..		TS 4	TORXT15	0.07
B1.02	572010502001	2.5 ~ 4	22	21								0.02
B1.04	572010504001	4 ~ 6	24	24								0.02
B3.06	572010506001	6 ~ 8	29	21			WCGT 0201..			TS 21	TORX T06	0.035
B3.08	572010508001	8 ~ 10	36	28			WCGT 0201..			TS 211	TORX T06	0.04
B3.10	572010510001	10 ~ 12	43	35			TPGX 0902..			CS 250 T	TORX T08	0.05
B3.11	572010511001	11 ~ 13	48	40			TPGX 0902..			CS 250 T	TORX T08	0.055
B3.12	572010512001	12 ~ 14	48	42			TPGX 0902..			CS 250 T	TORX T08	0.06
B3.14	572010514001	14 ~ 16	52	50			TPGX 0902..			CS 250 T	TORX T08	0.07
B3.16	572010516001	16 ~ 18	58	50			TPGX 0902..			CS 250 T	TORX T08	0.07
B3.18	572010518001	18 ~ 22	63				TPGX 0902..			CS 250 T	TORX T08	0.1
B3.22	572010522001	22 ~ 30	68				TPGX 0902..			CS 250 T	TORX T08	0.1
B5.06	572010506105	6 ~ 8	36				WCGT 0201..			TS 21	TORX T06	0.075
B5.08	572010508105	8 ~ 10	48				WCGT 0201..			TS 211	TORX T06	0.09
B5.10	572010510105	10 ~ 12	60				TPGX 0902..			CS 250 T	TORX T08	0.1
B5.12	572010512105	12 ~ 14	72				TPGX 0902..			CS 250 T	TORX T08	0.1
B5.14	572010514105	14 ~ 16	84				TPGX 0902..			CS 250 T	TORX T08	0.2
B5.16	572010516105	16 ~ 18	96				TPGX 0902..			CS 250 T	TORX T08	0.3
B8.06	572010506108	6 ~ 8	45				WCGT 0201..			TS 21	TORX T06	0.065
B8.08	572010508108	8 ~ 10	60				WCGT 0201..			TS 211	TORX T06	0.08
B8.10	572010510108	10 ~ 12	75				TPGX 0902..			CS 250 T	TORX T08	0.1
B8.12	572010512108	12 ~ 14	90				TPGX 0902..			CS 250 T	TORX T08	0.2
B8.14	572010514108	14 ~ 16	105				TPGX 0902..			CS 250 T	TORX T08	0.2
B8.16	572010516108	16 ~ 18	120				TPGX 0902..			CS 250 T	TORX T08	0.3

## TRM 50/63 - TRM 63/63 Ø 2.5 ~ 125



2 µm

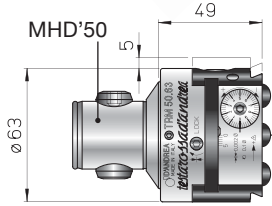

**TRM 50/63**  
Ø 2.5 ~ 125

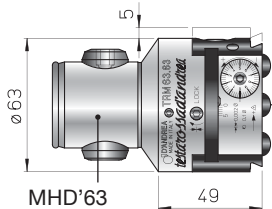

**TRM 63/63**  
Ø 2.5 ~ 125

REF.	CODE	Kg.
TRM 50/63	455005000631	1.1
TRM 63/63	455006300631	1.5
RDC D08.16	200560116082	0.02
P20.30	431030160300	0.2
PS 11.30 D.16	433030260755	0.4
P25.63 TR..	435116250631	0.5
P25.105 TR..	435116251051	0.8
P02.30	431030250400	0.3
P03.30	431030250700	0.4
P04.30	431030251150	0.7
PS 11.30	433030260750	0.4
PS 12.30	433030260950	0.5

### Utensili

### Utensili antivibranti

### Utensili in metallo duro

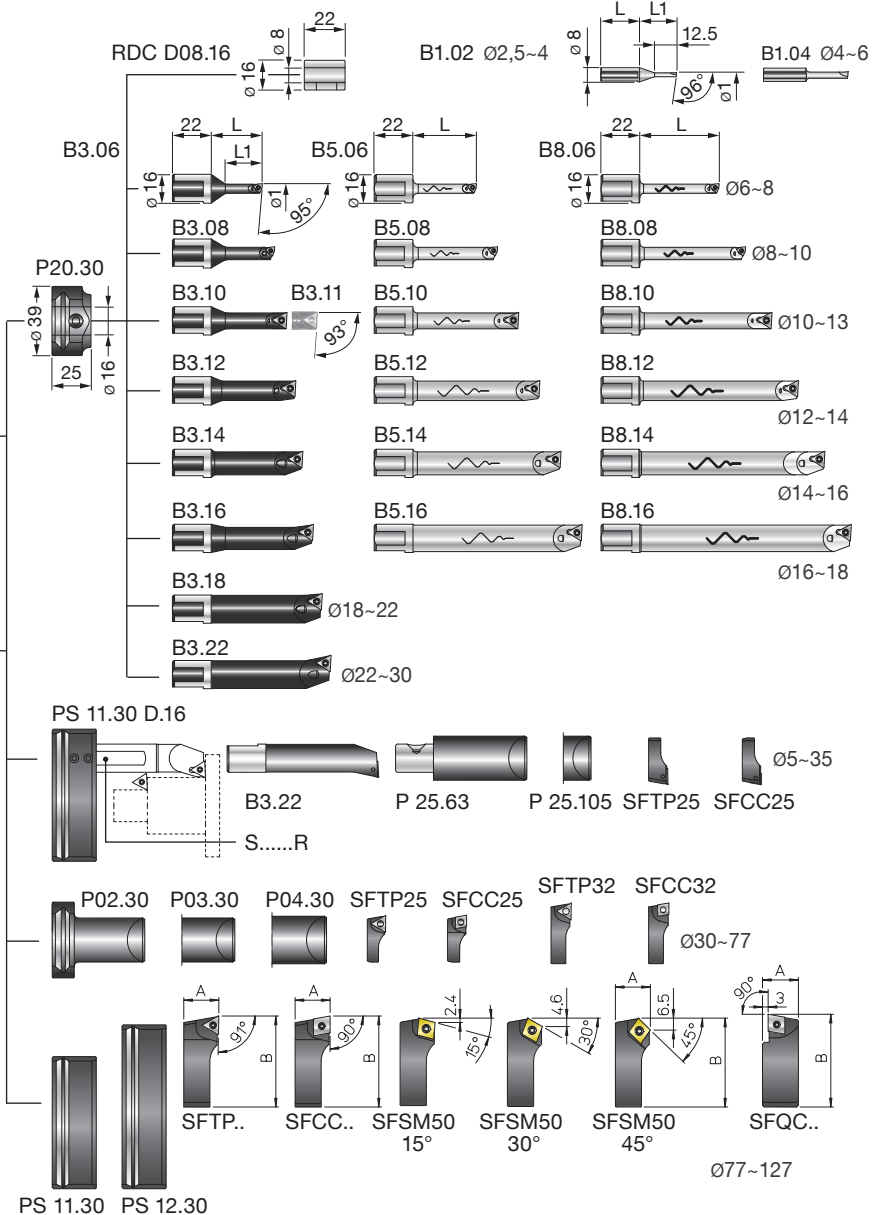

## KIT K01 Ø 6 ~ 125

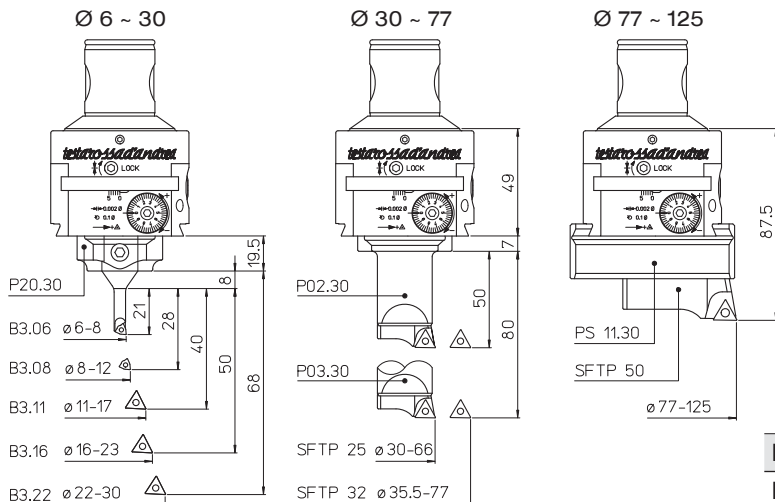

- 1 TRM../63
- 1 P20.30
- 1 PS11.30
- 1 P02.30
- 1 P03.30
- 1 B3.06
- 1 B3.08
- 1 B3.11
- 1 B3.16
- 1 B3.22
- 1 SFTP25
- 1 SFTP32
- 1 SFTP50
- 5 TPGX 090202L DC100
- 1 TPGX 110302L DC100
- 2 WCGT 020102L DC100

REF.	CODE	Ø	Kg.
KIT K01 TRM50/63	655005010632	6 ~ 125	3.9
KIT K01 TRM63/63	655006310632	6 ~ 125	4.2

## PS + P25 Ø 5 ~ 35

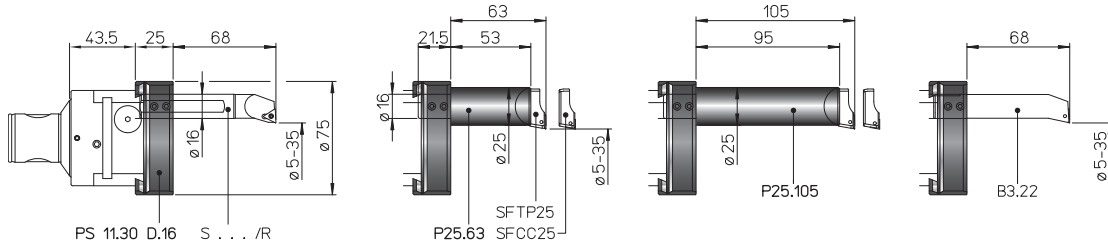

## P Ø 30 ~ 77

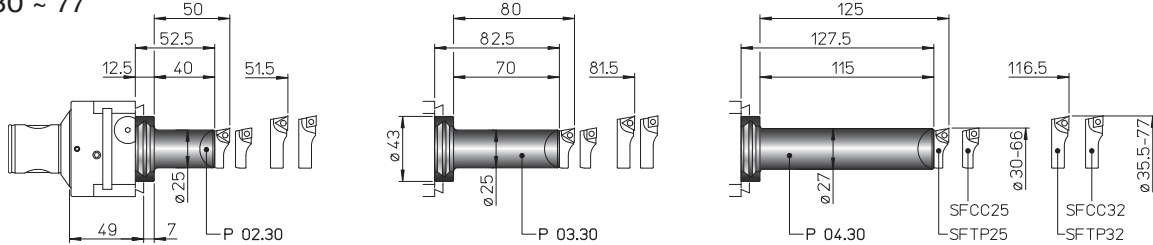

## PS Ø 77 ~ 127

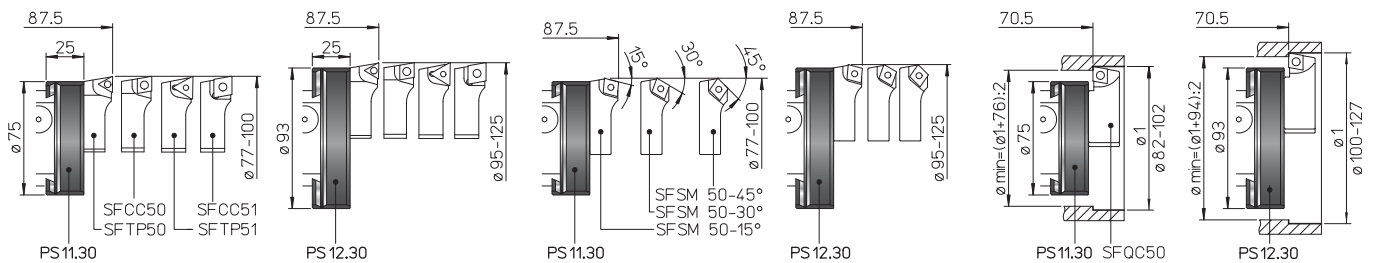

REF.	CODE	Ø1	L	L1	A	B						Kg.
SFTP 25	470500525001				10	26.5		TPGX 0902..		CS 250T	TORX T08	0.01
SFTP 32	470500532001				11.5	34.5		TPGX 0902..		CS 250T	TORX T08	0.02
SFTP 50	470500550001				19	52		TPGX 1103..		CS 300890T	TORX T08	0.08
SFTP 51	470500550003				21	52		TCMT 16T3..		TS 4	TORX T15	0.09
SFCC 25	470500525002				10	26.5			CCGT 0602..	TS 25	TORX T08	0.01
SFCC 32	470500532002				11.5	34.5			CCGT 0602..	TS 25	TORX T08	0.02
SFCC 50	470500550002				19	52			CCGT 09T3..	TS 4	TORX T15	0.08
SFCC 51	470500550004				21	52			CCMT 1204..	TS 5	TORX T25	0.09
SFQC 50	470500550062				20.5	53			CCMT 09T3..	TS 4	TORXT15	0.1
SFSM 50-15°	470500550011				19	50.5			CCMT 09T3..	TS 4	TORXT15	0.07
SFSM 50-30°	470500550013				19	50.5			CCMT 09T3..	TS 4	TORXT15	0.07
SFSM 50-45°	470500550015				19	50.5			CCMT 09T3..	TS 4	TORXT15	0.07
B1.02	572010502001	2.5 ~ 4	22	21								0.02
B1.04	572010504001	4 ~ 6	24	24								0.02
B3.06	572010506001	6 ~ 8	29	21			WCGT 0201..			TS 21	TORX T06	0.035
B3.08	572010508001	8 ~ 10	36	28			WCGT 0201..			TS 211	TORX T06	0.04
B3.10	572010510001	10 ~ 12	43	35				TPGX 0902..		CS 250 T	TORX T08	0.05
B3.11	572010511001	11 ~ 13	48	40				TPGX 0902..		CS 250 T	TORX T08	0.055
B3.12	572010512001	12 ~ 14	48	42				TPGX 0902..		CS 250 T	TORX T08	0.06
B3.14	572010514001	14 ~ 16	52	50				TPGX 0902..		CS 250 T	TORX T08	0.07
B3.16	572010516001	16 ~ 18	58	50				TPGX 0902..		CS 250 T	TORX T08	0.07
B3.18	572010518001	18 ~ 22	63					TPGX 0902..		CS 250 T	TORX T08	0.1
B3.22	572010522001	22 ~ 30	68					TPGX 0902..		CS 250 T	TORX T08	0.1
B5.06	572010506105	6 ~ 8	36				WCGT 0201..			TS 21	TORX T06	0.075
B5.08	572010508105	8 ~ 10	48				WCGT 0201..			TS 211	TORX T06	0.09
B5.10	572010510105	10 ~ 12	60					TPGX 0902..		CS 250 T	TORX T08	0.1
B5.12	572010512105	12 ~ 14	72					TPGX 0902..		CS 250 T	TORX T08	0.1
B5.14	572010514105	14 ~ 16	84					TPGX 0902..		CS 250 T	TORX T08	0.2
B5.16	572010516105	16 ~ 18	96					TPGX 0902..		CS 250 T	TORX T08	0.3
B8.06	572010506108	6 ~ 8	45				WCGT 0201..			TS 21	TORX T06	0.065
B8.08	572010508108	8 ~ 10	60				WCGT 0201..			TS 211	TORX T06	0.08
B8.10	572010510108	10 ~ 12	75					TPGX 0902..		CS 250 T	TORX T08	0.1
B8.12	572010512108	12 ~ 14	90					TPGX 0902..		CS 250 T	TORX T08	0.2
B8.14	572010514108	14 ~ 16	105					TPGX 0902..		CS 250 T	TORX T08	0.2
B8.16	572010516108	16 ~ 18	120					TPGX 0902..		CS 250 T	TORX T08	0.3



## TRM 50/80 - TRM 80/80 Ø 2.5 ~ 160



2 µm

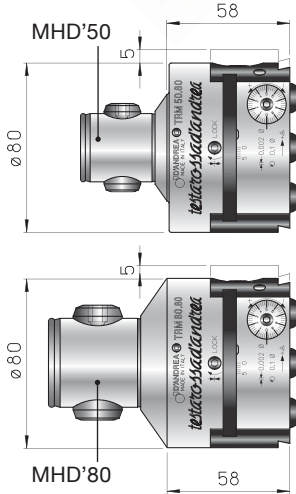

TRM 50/80  
Ø 2.5 ~ 160

TRM 80/80  
Ø 2.5 ~ 160

Utensili

Utensili antivibranti

Utensili in metallo duro

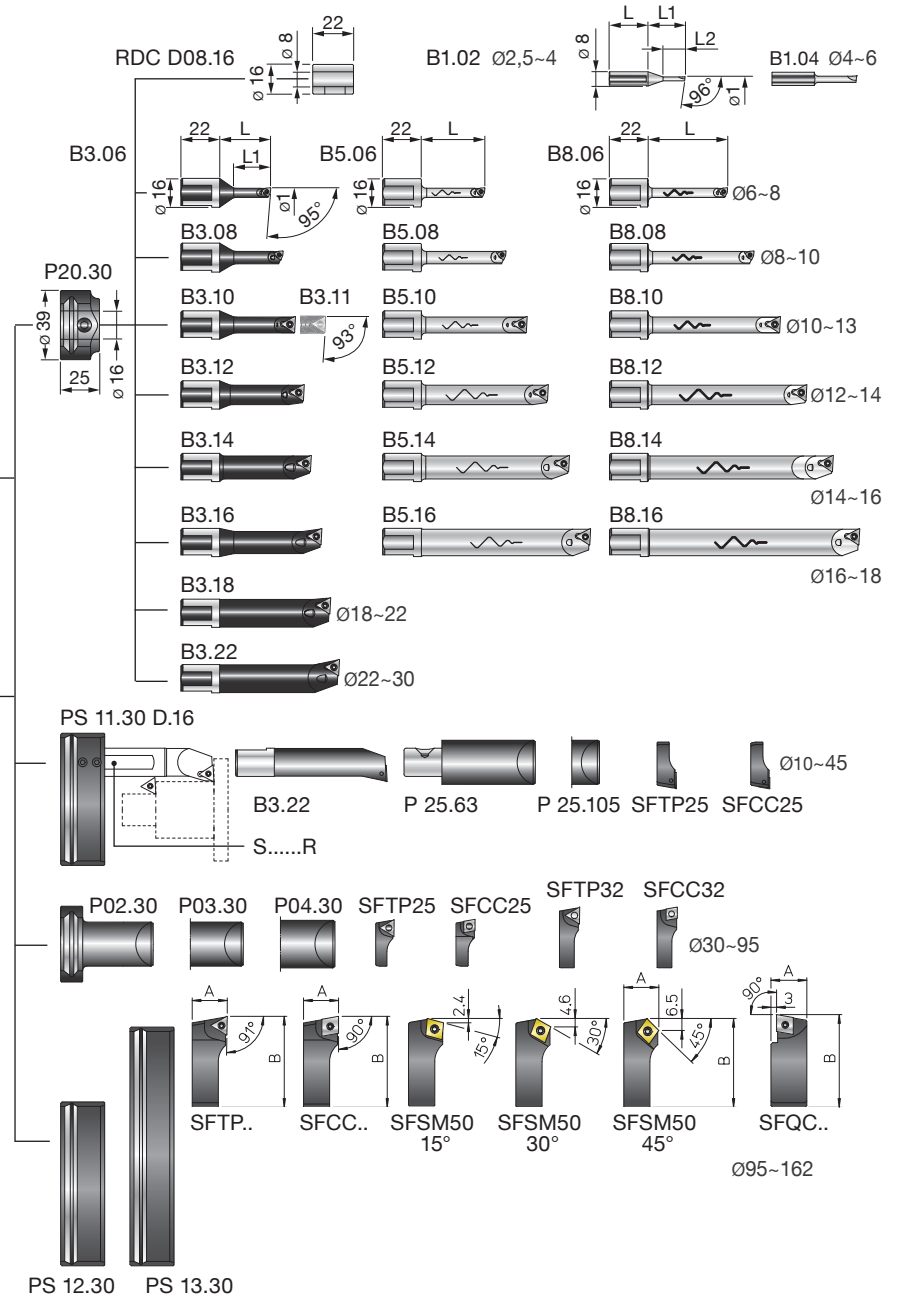

REF.	CODE	Kg.
TRM 50/80	455005000801	2
TRM 80/80	455008000801	2.5
RDC D08.16	200560116082	0.02
P20.30	431030160300	0.2
PS 11.30 D.16	433030260755	0.4
P25.63 TR..	435116250631	0.5
P25.105 TR..	435116251051	0.8
P02.30	431030250400	0.3
P03.30	431030250700	0.4
P04.30	431030251150	0.7
PS 11.30	433030260750	0.4
PS 12.30	433030260950	0.5

## KIT K01 Ø 6 ~ 220

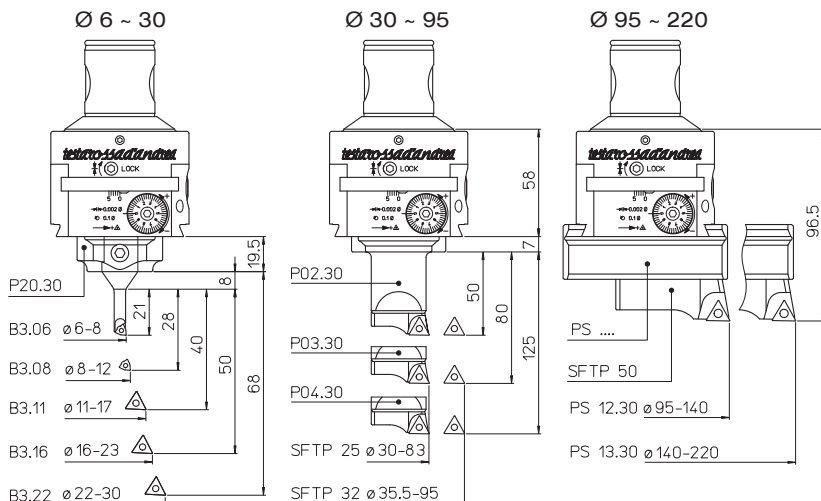

- 1 TRM../80
- 1 P20.30
- 1 PS12.30
- 1 PS13.30
- 1 P03.30
- 1 P04.30
- 1 B3.06
- 1 B3.08
- 1 B3.11
- 1 B3.16
- 1 B3.22
- 1 SFTP25
- 1 SFTP32
- 1 SFTP50
- 5 TPGX 090202L DC100
- 1 TPGX 110302L DC100
- 2 WCGT 020102L DC100

REF.	CODE	Ø	Kg.
KIT K01 TRM50/80	655005010802	6 ~ 220	6.2
KIT K01 TRM80/80	655008010802	6 ~ 220	6.6

## PS + P25 Ø 10 ~ 45

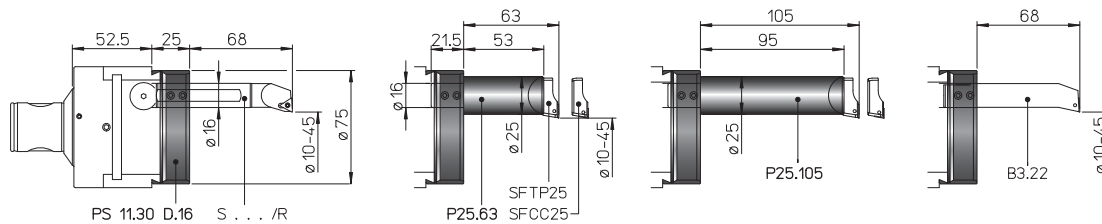

## P Ø 30 ~ 95

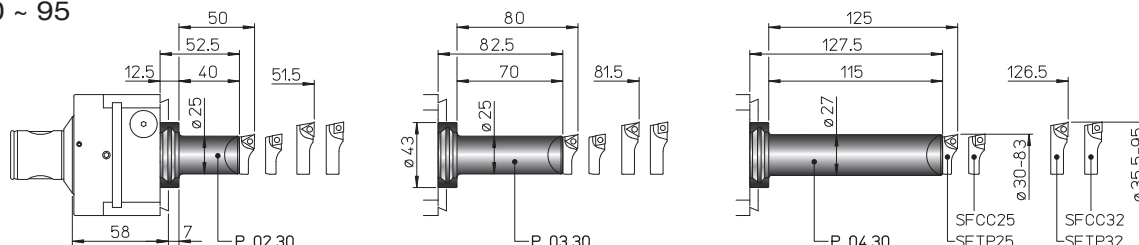

## PS Ø 95 ~ 162

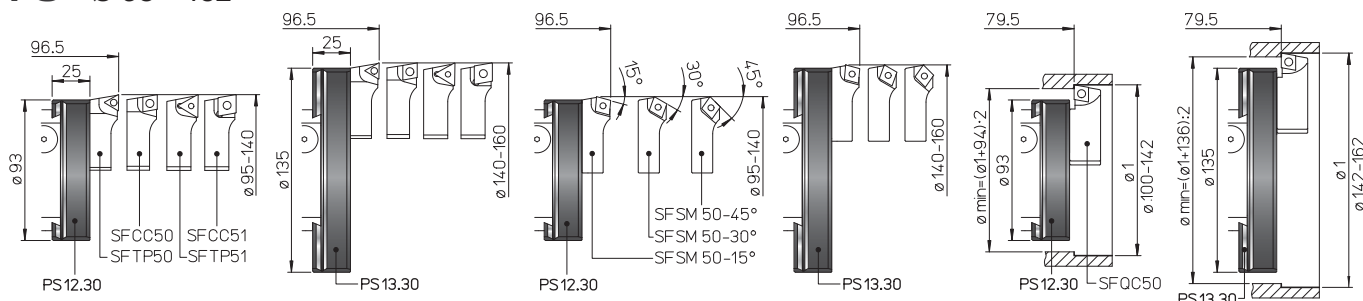

REF.	CODE	Ø1	L	L1	A	B	⊖	⊕	⊖	⊕	Kg.
SFTP 25	470500525001		10	26.5			TPGX 0902..		CS 250T	TORX T08	0.01
SFTP 32	470500532001		11.5	34.5			TPGX 0902..		CS 250T	TORX T08	0.02
SFTP 50	470500550001		19	52			TPGX 1103..		CS 300890T	TORX T08	0.08
SFTP 51	470500550003		21	52			TCMT 16T3..		TS 4	TORX T15	0.09
SFCC 25	470500525002		10	26.5			CCGT 0602..		TS 25	TORX T08	0.01
SFCC 32	470500532002		11.5	34.5			CCGT 0602..		TS 25	TORX T08	0.02
SFCC 50	470500550002		19	52			CCGT 09T3..		TS 4	TORX T15	0.08
SFCC 51	470500550004		21	52			CCMT 1204..		TS 5	TORX T25	0.09
SFQC 50	470500550062		20.5	53			CCMT 09T3..		TS 4	TORX T15	0.1
SFSM 50-15°	470500550011		19	50.5			CCMT 09T3..		TS 4	TORX T15	0.07
SFSM 50-30°	470500550013		19	50.5			CCMT 09T3..		TS 4	TORX T15	0.07
SFSM 50-45°	470500550015		19	50.5			CCMT 09T3..		TS 4	TORX T15	0.07

B1.02	572010502001	2.5 ~ 4	22	21							0.02
B1.04	572010504001	4 ~ 6	24	24							0.02
B3.06	572010506001	6 ~ 8	29	21		WCGT 0201..			TS 21	TORX T06	0.035
B3.08	572010508001	8 ~ 10	36	28		WCGT 0201..			TS 211	TORX T06	0.04
B3.10	572010510001	10 ~ 12	43	35			TPGX 0902..		CS 250 T	TORX T08	0.05
B3.11	572010511001	11 ~ 13	48	40			TPGX 0902..		CS 250 T	TORX T08	0.055
B3.12	572010512001	12 ~ 14	48	42			TPGX 0902..		CS 250 T	TORX T08	0.06
B3.14	572010514001	14 ~ 16	52	50			TPGX 0902..		CS 250 T	TORX T08	0.07
B3.16	572010516001	16 ~ 18	58	50			TPGX 0902..		CS 250 T	TORX T08	0.07
B3.18	572010518001	18 ~ 22	63				TPGX 0902..		CS 250 T	TORX T08	0.1
B3.22	572010522001	22 ~ 30	68				TPGX 0902..		CS 250 T	TORX T08	0.1
B5.06	572010506105	6 ~ 8	36			WCGT 0201..			TS 21	TORX T06	0.075
B5.08	572010508105	8 ~ 10	48			WCGT 0201..			TS 211	TORX T06	0.09
B5.10	572010510105	10 ~ 12	60				TPGX 0902..		CS 250 T	TORX T08	0.1
B5.12	572010512105	12 ~ 14	72				TPGX 0902..		CS 250 T	TORX T08	0.1
B5.14	572010514105	14 ~ 16	84				TPGX 0902..		CS 250 T	TORX T08	0.2
B5.16	572010516105	16 ~ 18	96				TPGX 0902..		CS 250 T	TORX T08	0.3
B8.06	572010506108	6 ~ 8	45			WCGT 0201..			TS 21	TORX T06	0.065
B8.08	572010508108	8 ~ 10	60			WCGT 0201..			TS 211	TORX T06	0.08
B8.10	572010510108	10 ~ 12	75				TPGX 0902..		CS 250 T	TORX T08	0.1
B8.12	572010512108	12 ~ 14	90				TPGX 0902..		CS 250 T	TORX T08	0.2
B8.14	572010514108	14 ~ 16	105				TPGX 0902..		CS 250 T	TORX T08	0.2
B8.16	572010516108	16 ~ 18	120				TPGX 0902..		CS 250 T	TORX T08	0.3

## TRM 80/125 Ø 36 ~ 500



2 μm

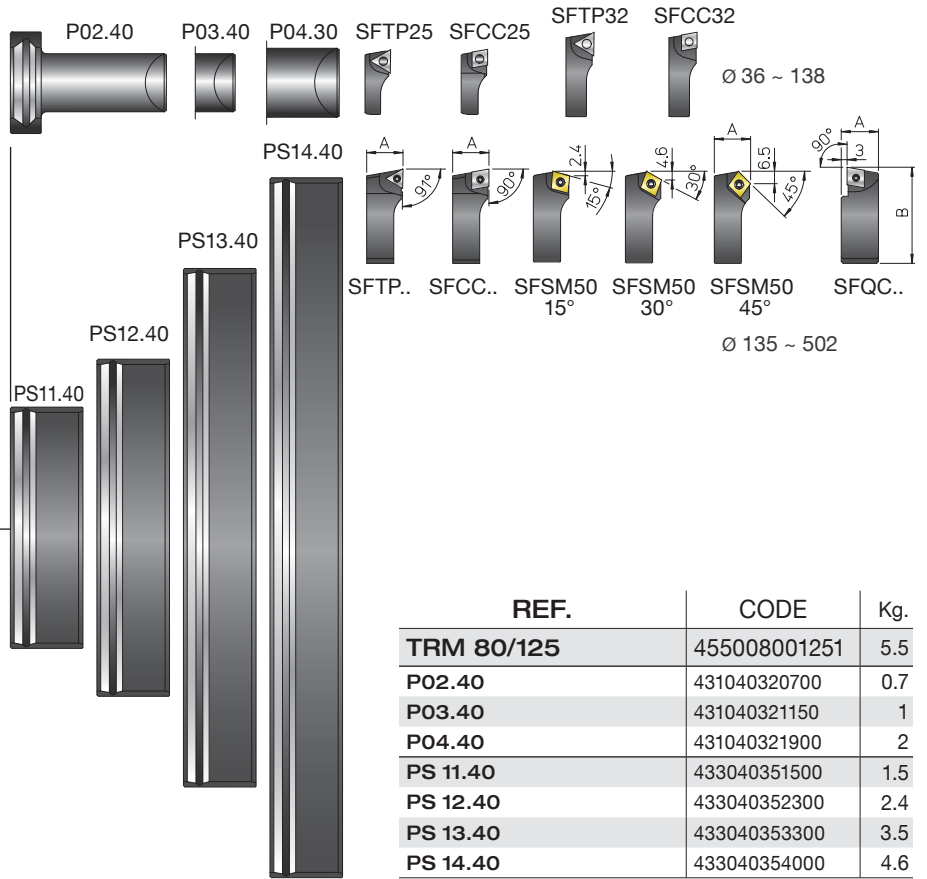
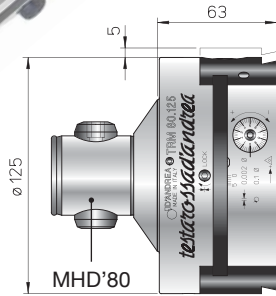

REF.	CODE	Kg.
TRM 80/125	455008001251	5.5
P02.40	431040320700	0.7
P03.40	431040321150	1
P04.40	431040321900	2
PS 11.40	433040351500	1.5
PS 12.40	433040352300	2.4
PS 13.40	433040353300	3.5
PS 14.40	433040354000	4.6

## KIT K03 Ø 36 ~ 410

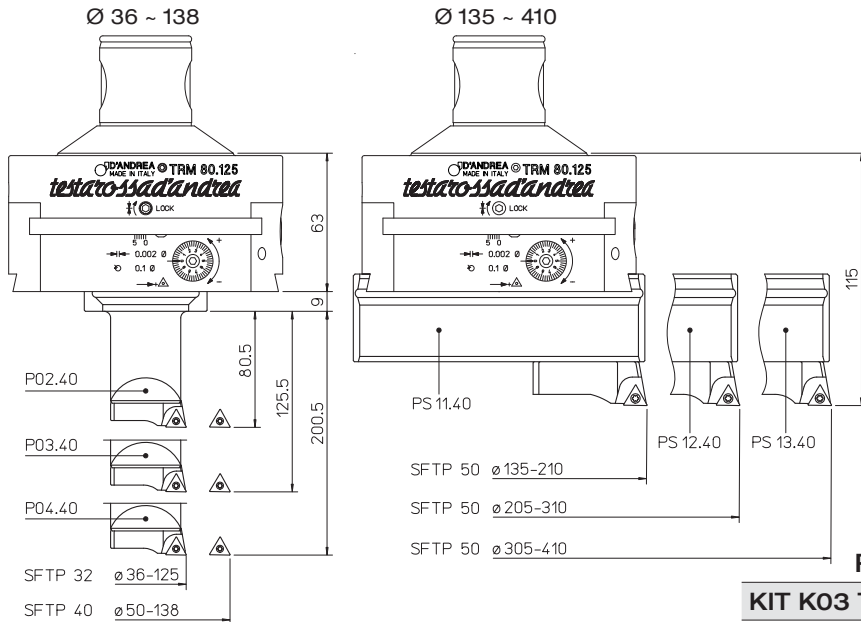

1 P02.40 1 PS11.40 1 SFTP32  
 1 P03.40 1 PS12.40 1 SFTP40  
 1 P04.40 1 PS13.40 1 SFTP50

### TRM 80/125 ESCULSA

REF.	CODE	Ø	Kg.
KIT K03 TRM 80/125	655012500030	36 ~ 410	11.2

## P Ø 36 ~ 138

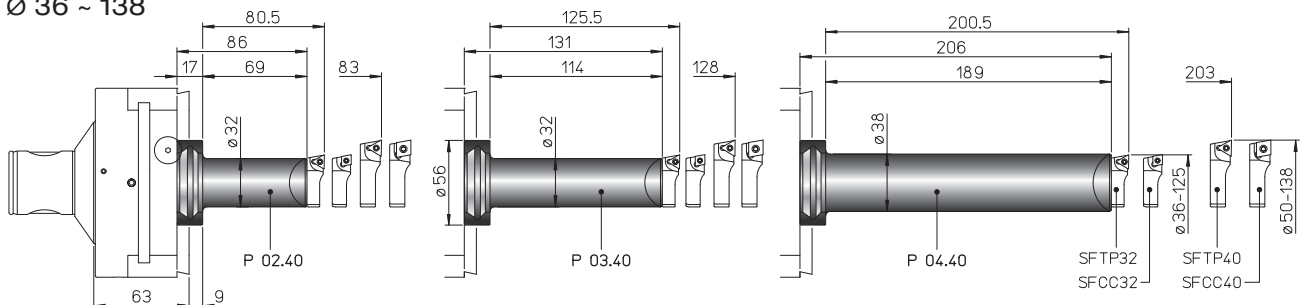

## PS Ø 135 ~ 500

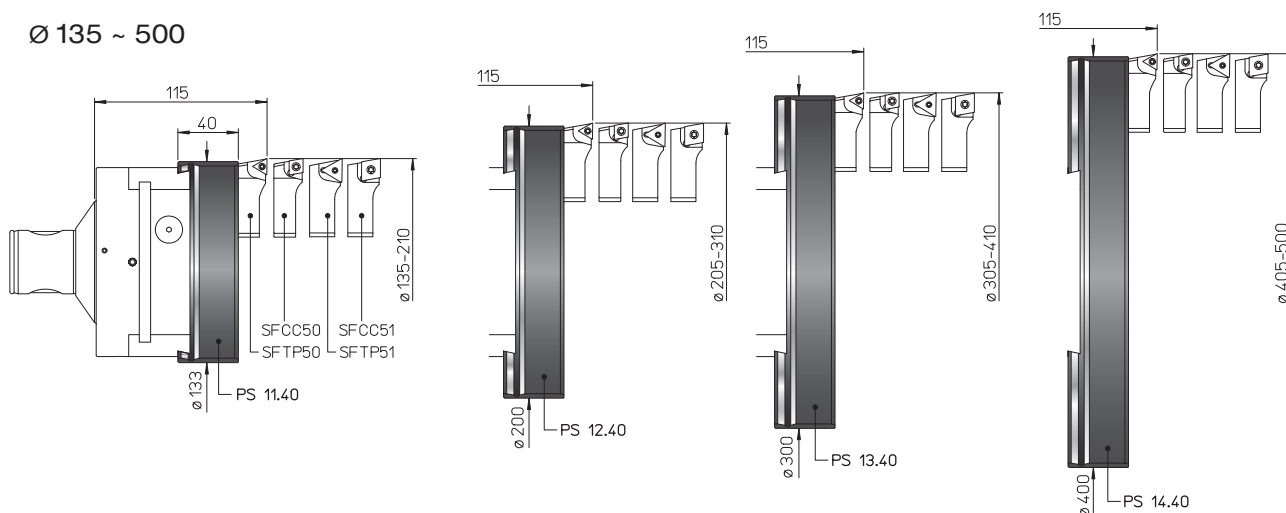

## PS Ø 135 ~ 500

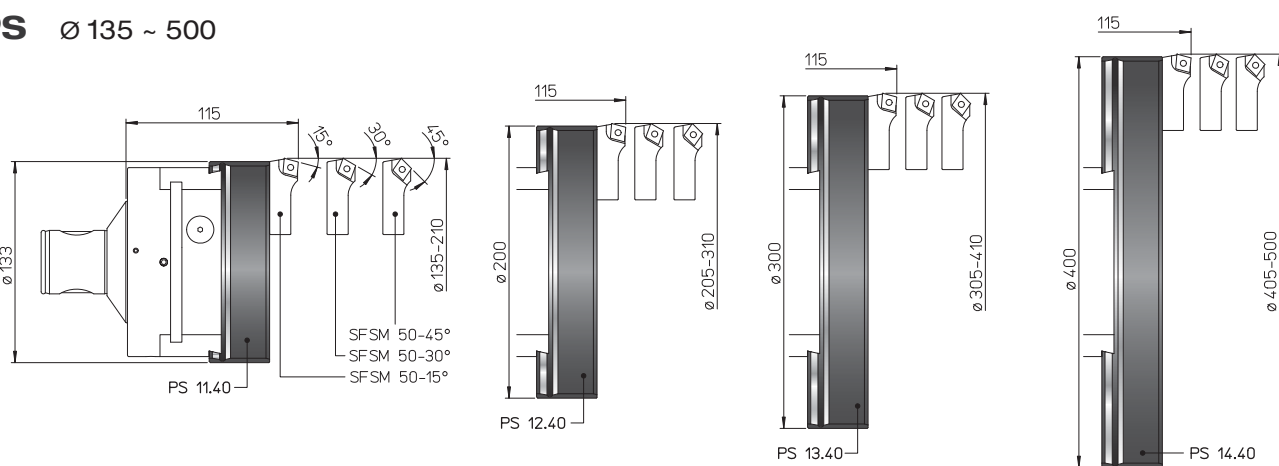

## PS Ø 140 ~ 502

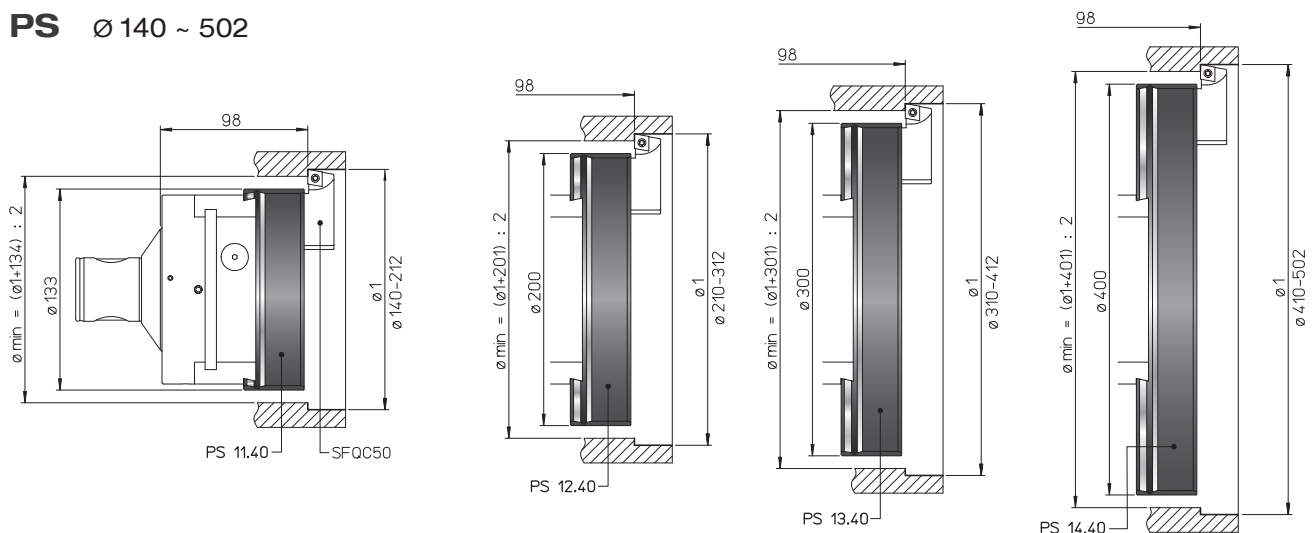

REF.	CODE	A	B					Kg.
SFTP 32	470500532001	11.5	34.5	TPGX 0902..		CS 250T	TORX T08	0.02
SFTP 40	470500540001	14	44	TPGX 1103..		CS 300890T	TORX T08	0.04
SFTP 50	470500550001	19	52	TPGX 1103..		CS 300890T	TORX T08	0.08
SFTP 51	470500550003	21	52	TCMT 16T3..		TS 4	TORX T15	0.09
SFCC 32	470500532002	11.5	34.5		CCGT 0602..	TS 25	TORX T08	0.02
SFCC 40	470500540002	14	44		CCGT 09T3..	TS 4	TORX T15	0.04
SFCC 50	470500550002	19	52		CCGT 09T3..	TS 4	TORX T15	0.08
SFCC 51	470500550004	21	52		CCMT 1204..	TS 5	TORX T25	0.09
SFQC 50	470500550062	20.5	53		CCMT 09T3..	TS 4	TORXT15	0.1
SFSM 50-15°	470500550011	19	50.5		CCMT 09T3..	TS 4	TORXT15	0.07
SFSM 50-30°	470500550013	19	50.5		CCMT 09T3..	TS 4	TORXT15	0.07
SFSM 50-45°	470500550015	19	50.5		CCMT 09T3..	TS 4	TORXT15	0.07

## TRC 14 ~ 40 Ø 14.5 ~ 66



**10 µm**  
nonio  
vernier **2 µm**

REF.	CODE	Ø	Kg.
<b>TRC 14</b>	455011400301	14.5 ~ 18	0.02
<b>TRC 16</b>	455011600341	18 ~ 24	0.05
<b>TRC 20</b>	455012000401	22 ~ 30	0.1
<b>TRC 25</b>	455012500501	28 ~ 40	0.2
<b>TRC 32</b>	455013200631	35.5 ~ 53.5	0.35
<b>TRC 40</b>	455014000801	48 ~ 66	0.7

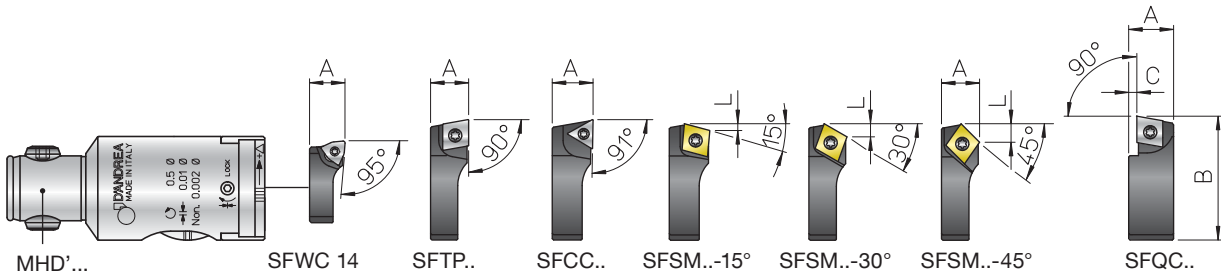

## SEGGI SFWC.. - SFCC .. - SFTP .. - SFSM .. - SFQC ..



REF.	CODE	A	B	C	L						Kg.
<b>SFWC 14</b>	470500514002	8	14			WCGT 0201..			TS 211	TORX T06	0.003
<b>SFCC 16</b>	470500516002	8	17			CCGT 0602..			TS 25	TORX T08	0.003
<b>SFCC 20</b>	470500520002	8.5	21			CCGT 0602..			TS 25	TORX T08	0.005
<b>SFCC 25</b>	470500525002	10	26.5			CCGT 0602..			TS 25	TORX T08	0.01
<b>SFCC 32</b>	470500532002	11.5	34.5			CCGT 0602..			TS 25	TORX T08	0.02
<b>SFCC 40</b>	470500540002	14	44			CCGT 09T3..			TS 4	TORX T15	0.04
<b>SFTP 25</b>	470500525001	10	26.5				TPGX 0902..	CS 250T	TORX T08	TORX T08	0.01
<b>SFTP 32</b>	470500532001	11.5	34.5				TPGX 0902..	CS 250T	TORX T08	TORX T08	0.02
<b>SFTP 40</b>	470500540001	14	44				TPGX 1103..	CS 300890T	TORX T08	TORX T08	0.04
<b>SFQC 16</b>	470500516062	10	18	2		CCMT 0602..			TS 25	TORX T08	0.005
<b>SFQC 20</b>	470500520062	10.5	22.5	2		CCMT 0602..			TS 25	TORX T08	0.008
<b>SFQC 25</b>	470500525062	12	28.5	2.5		CCMT 0602..			TS 25	TORX T08	0.01
<b>SFQC 32</b>	470500532062	13.5	35.5	2.5		CCMT 0602..			TS 25	TORX T08	0.03
<b>SFQC 40</b>	470500540062	16.5	46	3		CCMT 09T3..			TS 4	TORX T15	0.06
<b>SFSM 25-15°</b>	470500525011	10	25.5	1.6		CCMT 0602..			TS 25	TORX T08	0.01
<b>SFSM 25-30°</b>	470500525013	10	25.5	3		CCMT 0602..			TS 25	TORX T08	0.01
<b>SFSM 25-45°</b>	470500525015	10	25.5	4.3		CCMT 0602..			TS 25	TORX T08	0.01
<b>SFSM 32-15°</b>	470500532011	11.5	33.5	1.6		CCMT 0602..			TS 25	TORX T08	0.02
<b>SFSM 32-30°</b>	470500532013	11.5	33.5	3		CCMT 0602..			TS 25	TORX T08	0.02
<b>SFSM 32-45°</b>	470500532015	11.5	33.5	4.3		CCMT 0602..			TS 25	TORX T08	0.02
<b>SFSM 40-15°</b>	470500540011	14	42.5	2.4		CCMT 09T3..			TS 4	TORX T15	0.03
<b>SFSM 40-30°</b>	470500540013	14	42.5	4.6		CCMT 09T3..			TS 4	TORX T15	0.03
<b>SFSM 40-45°</b>	470500540015	14	42.5	6.5		CCMT 09T3..			TS 4	TORX T15	0.03



## TRC 14 Ø 14.5 ~ 18

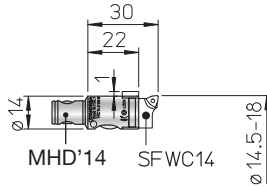

## TRC 16 Ø 18 ~ 24

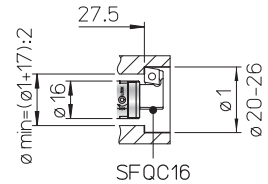
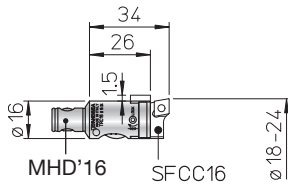

## TRC 20 Ø 22 ~ 30

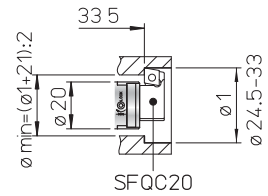
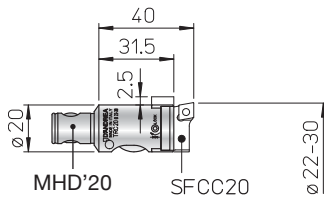

## TRC 25 Ø 28 ~ 40

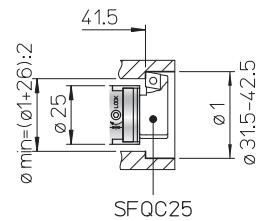
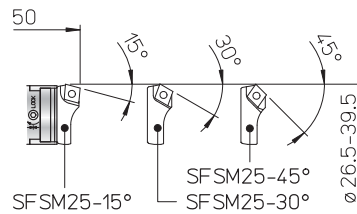
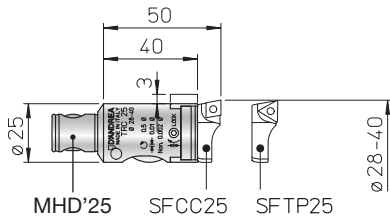

## TRC 32 Ø 35.5 ~ 53.5

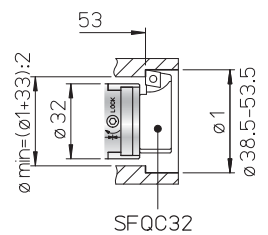
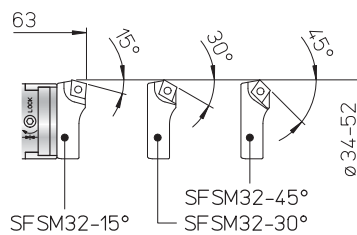
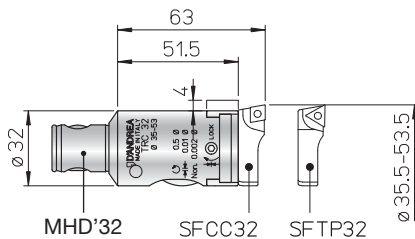

## TRC 40 Ø 48 ~ 66

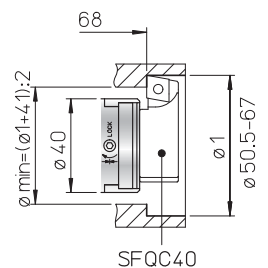
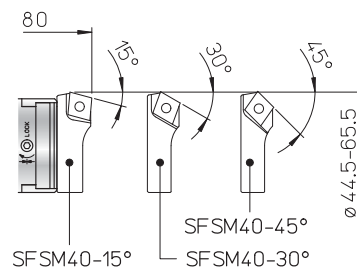
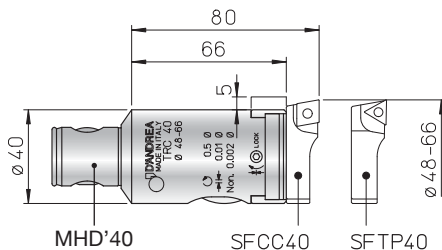

## TRC 50 Ø 2.5 ~ 110

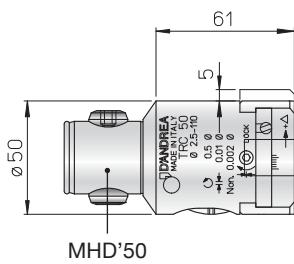

REF.	CODE	Kg.
<b>TRC 50</b>	455015000801	1
<b>RDC D08.16</b>	200560116082	0.02
<b>P25.63 TR..</b>	435116250631	0.5
<b>P25.105 TR..</b>	435116251051	0.8
<b>PS 31.24 TR..</b>	433024140751	0.19
<b>CW 32</b>	392011003201	0.07

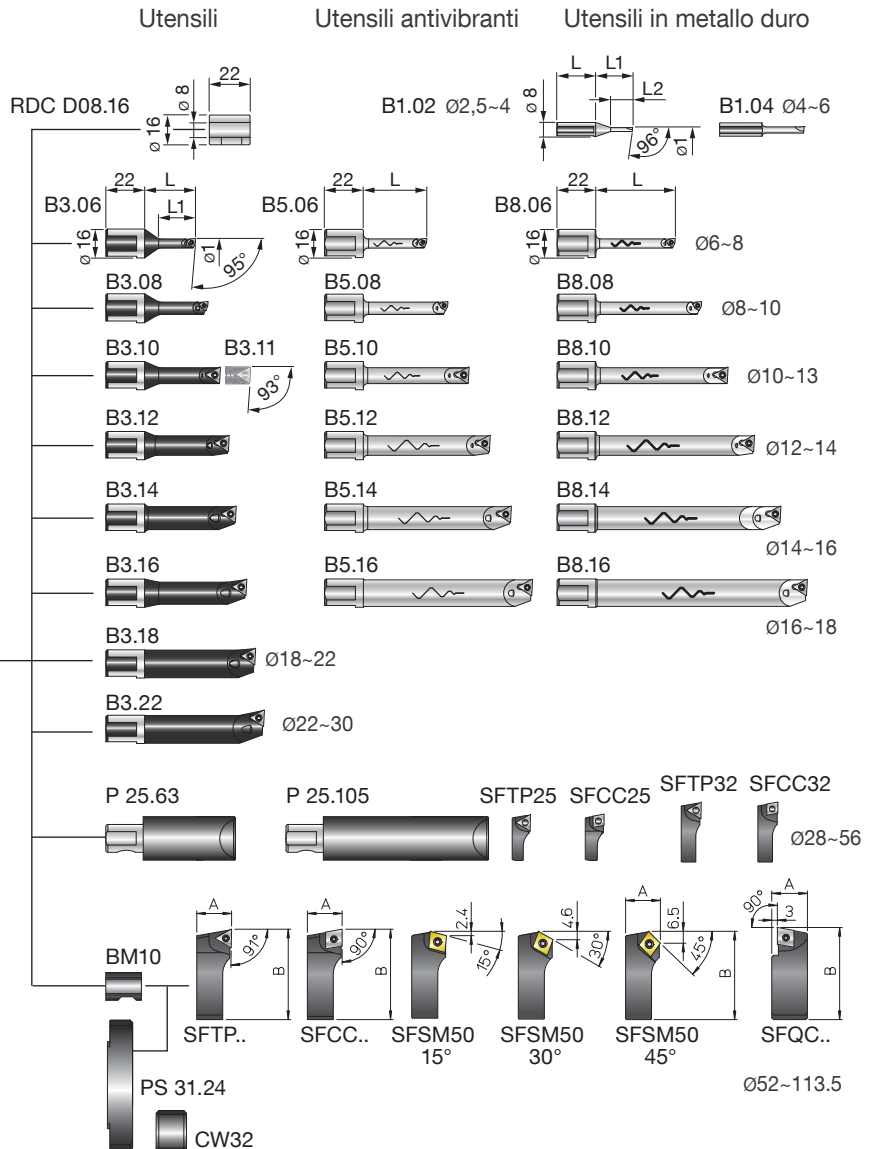

## KIT K01 Ø 6 ~ 110

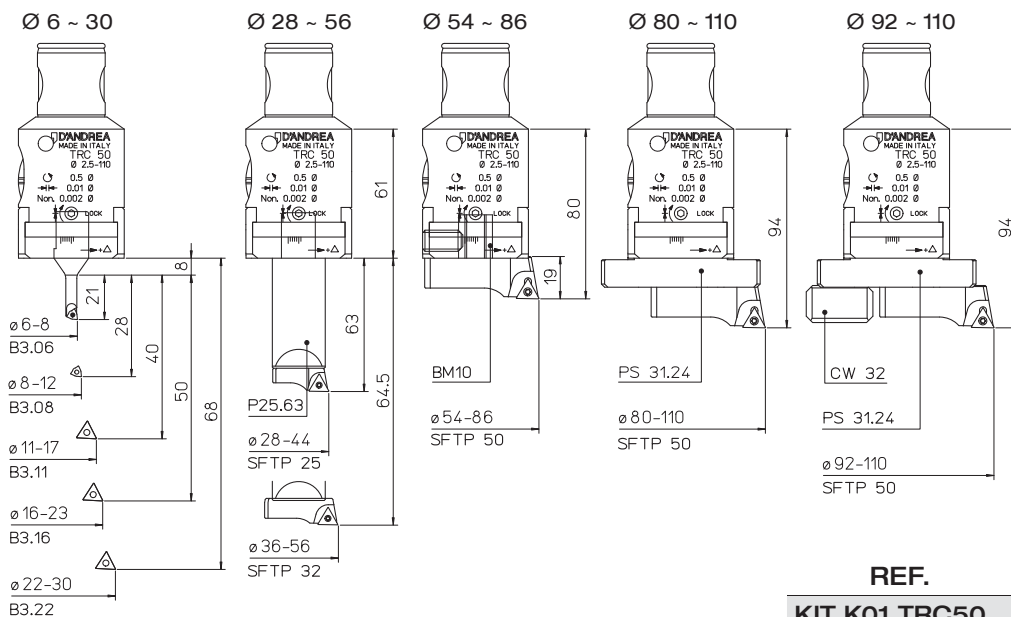

- 1 TRC 50
- 1 BM10
- 1 P25.63
- 1 PS 31.24
- 1 CW 32
- 1 B3.06
- 1 B3.08
- 1 B3.11
- 1 B3.16
- 1 B3.22
- 1 SFTP25
- 1 SFTP32
- 1 SFTP50
- 5 TPGX 090202L DC100
- 1 TPGX 110302L DC100
- 2 WCGT 020102L DC100

REF.	CODE	Ø	Kg.
<b>KIT K01 TRC50</b>	655015010502	6 ~ 110	3.1

## P 25 Ø 28 ~ 56

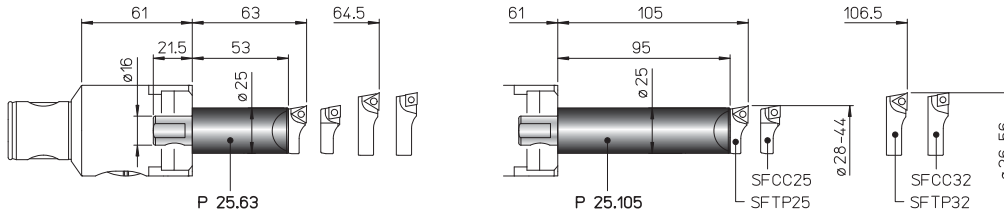

## PS 31.24 Ø 54 ~ 110

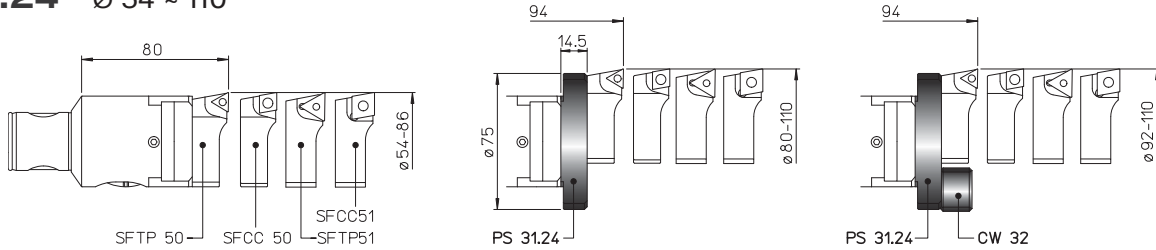

## PS 31.24 Ø 52 ~ 113.5

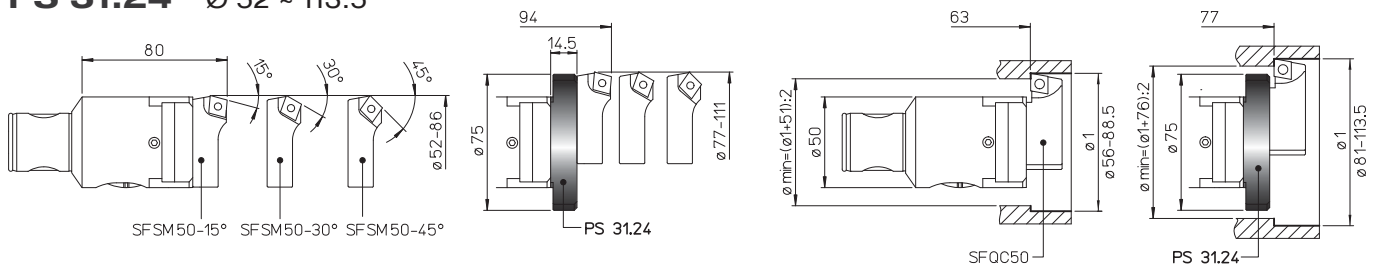

REF.	CODE	Ø1	L	L1	A	B	⊖	⊖	⊖	⊖	⊖	Kg.
SFTP 25	470500525001				10	26.5		TPGX 0902..		CS 250T	TORX T08	0.01
SFTP 32	470500532001				11.5	34.5		TPGX 0902..		CS 250T	TORX T08	0.02
SFTP 50	470500550001				19	52		TPGX 1103..		CS 300890T	TORX T08	0.08
SFTP 51	470500550003				21	52		TCMT 16T3..		TS 4	TORX T15	0.09
SFCC 25	470500525002				10	26.5		CCGT 0602..		TS 25	TORX T08	0.01
SFCC 32	470500532002				11.5	34.5		CCGT 0602..		TS 25	TORX T08	0.02
SFCC 50	470500550002				19	52		CCGT 09T3..		TS 4	TORX T15	0.08
SFCC 51	470500550004				21	52		CCMT 1204..		TS 5	TORX T25	0.09
SFQC 50	470500550062				20.5	53		CCMT 09T3..		TS 4	TORX T15	0.1
SFSM 50-15°	470500550011				19	50.5		CCMT 09T3..		TS 4	TORX T15	0.07
SFSM 50-30°	470500550013				19	50.5		CCMT 09T3..		TS 4	TORX T15	0.07
SFSM 50-45°	470500550015				19	50.5		CCMT 09T3..		TS 4	TORX T15	0.07
B1.02	572010502001	2.5 ~ 4	22	21								0.02
B1.04	572010504001	4 ~ 6	24	24								0.02
B3.06	572010506001	6 ~ 8	29	21			WCGT 0201..			TS 21	TORX T06	0.035
B3.08	572010508001	8 ~ 10	36	28			WCGT 0201..			TS 211	TORX T06	0.04
B3.10	572010510001	10 ~ 12	43	35				TPGX 0902..		CS 250 T	TORX T08	0.05
B3.11	572010511001	11 ~ 13	48	40				TPGX 0902..		CS 250 T	TORX T08	0.055
B3.12	572010512001	12 ~ 14	48	42				TPGX 0902..		CS 250 T	TORX T08	0.06
B3.14	572010514001	14 ~ 16	52	50				TPGX 0902..		CS 250 T	TORX T08	0.07
B3.16	572010516001	16 ~ 18	58	50				TPGX 0902..		CS 250 T	TORX T08	0.07
B3.18	572010518001	18 ~ 22	63					TPGX 0902..		CS 250 T	TORX T08	0.1
B3.22	572010522001	22 ~ 30	68					TPGX 0902..		CS 250 T	TORX T08	0.1
B5.06	572010506105	6 ~ 8	36				WCGT 0201..			TS 21	TORX T06	0.075
B5.08	572010508105	8 ~ 10	48				WCGT 0201..			TS 211	TORX T06	0.09
B5.10	572010510105	10 ~ 12	60					TPGX 0902..		CS 250 T	TORX T08	0.1
B5.12	572010512105	12 ~ 14	72					TPGX 0902..		CS 250 T	TORX T08	0.1
B5.14	572010514105	14 ~ 16	84					TPGX 0902..		CS 250 T	TORX T08	0.2
B5.16	572010516105	16 ~ 18	96					TPGX 0902..		CS 250 T	TORX T08	0.3
B8.06	572010506108	6 ~ 8	45				WCGT 0201..			TS 21	TORX T06	0.065
B8.08	572010508108	8 ~ 10	60				WCGT 0201..			TS 211	TORX T06	0.08
B8.10	572010510108	10 ~ 12	75					TPGX 0902..		CS 250 T	TORX T08	0.1
B8.12	572010512108	12 ~ 14	90					TPGX 0902..		CS 250 T	TORX T08	0.2
B8.14	572010514108	14 ~ 16	105					TPGX 0902..		CS 250 T	TORX T08	0.2
B8.16	572010516108	16 ~ 18	120					TPGX 0902..		CS 250 T	TORX T08	0.3

TRC 63 Ø 6 ~ 125

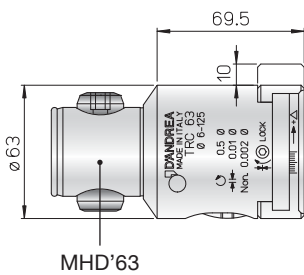

REF.	CODE	Kg.
TRC 63	455016301001	2
P 22.28	433028220631	0.45
PS 31.28 TRC 63	433028220801	0.3
CW 32	392011003201	0.07

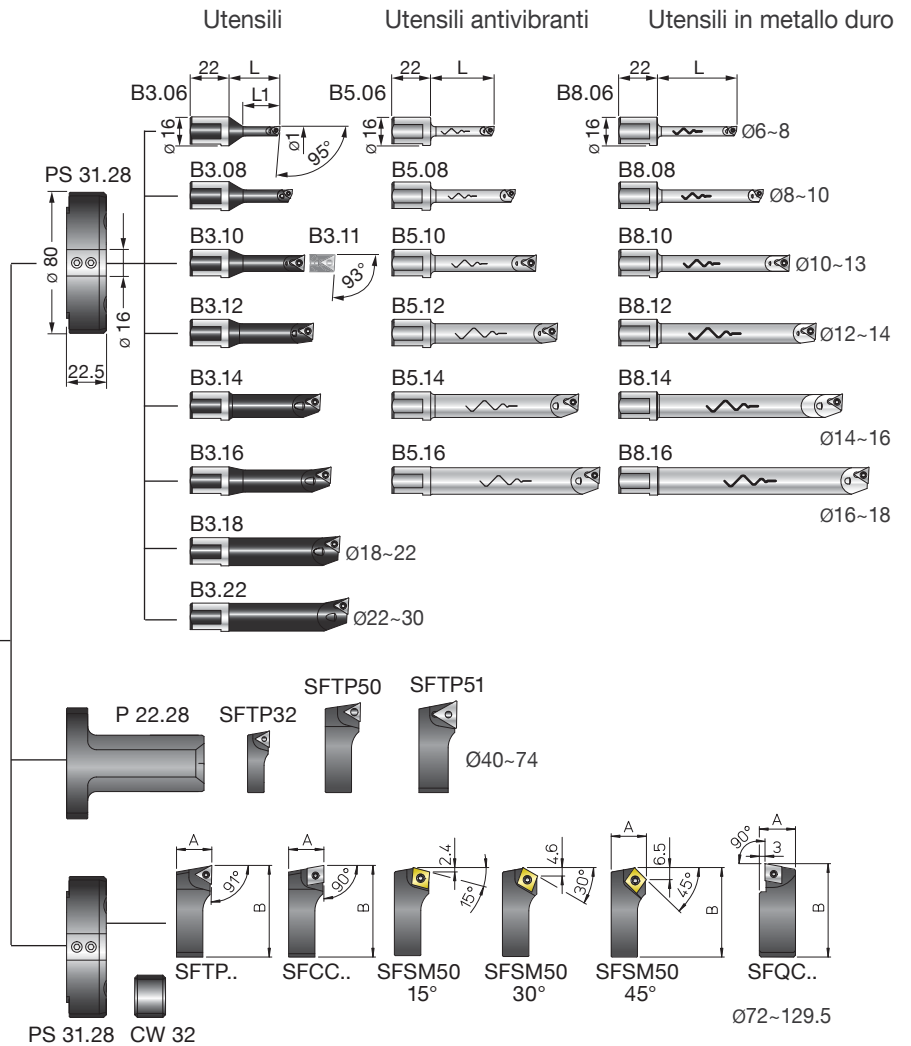

KIT K01 Ø 6 ~ 125

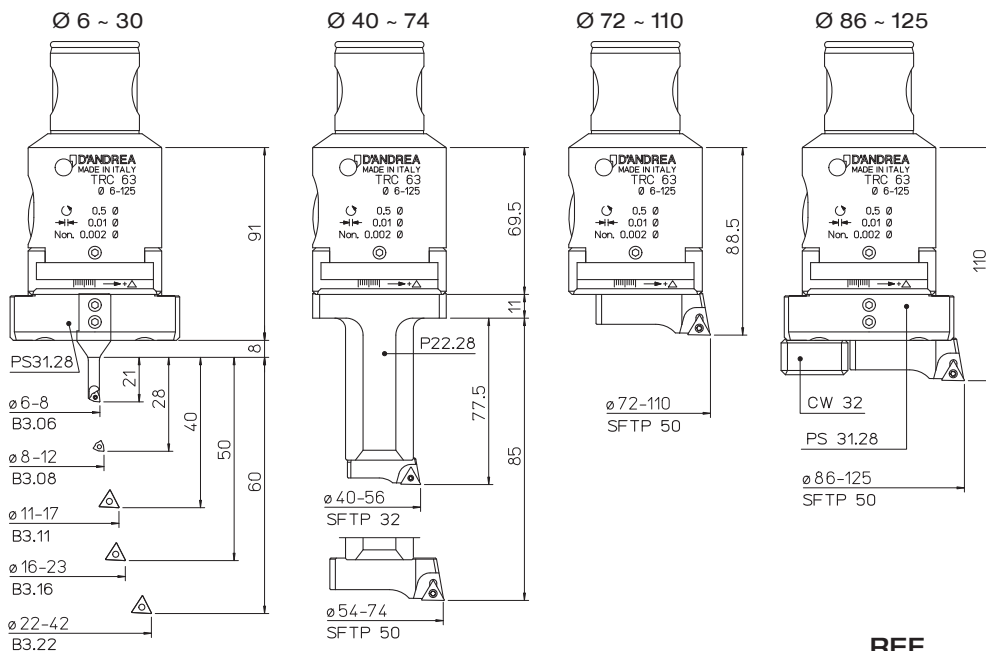

- 1 TRC 63
- 1 PS31.28
- 1 CW 32
- 1 P22.28
- 1 B3.06
- 1 B3.08
- 1 B3.11
- 1 B3.16
- 1 B3.22
- 1 SFTP32
- 1 SFTP50
- 5 TPGX 090202L DC100
- 1 TPGX 110302L DC100
- 2 WCGT 020102L DC100

REF.	CODE	Ø	Kg.
KIT K01 TRC 63	655016310632	6 ~ 125	4.5

## P 22 Ø 40 ~ 74

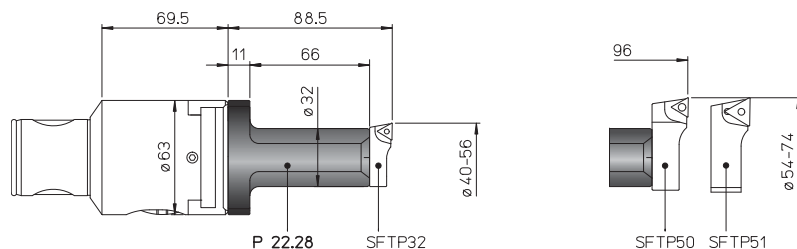

## PS 31.28 Ø 72 ~ 125

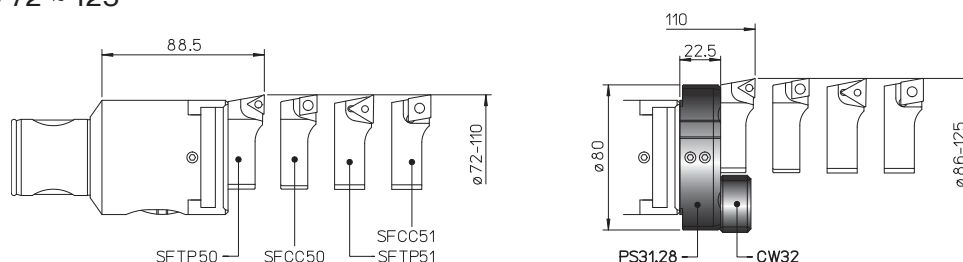

## PS 31.28 Ø 69 ~ 129.5

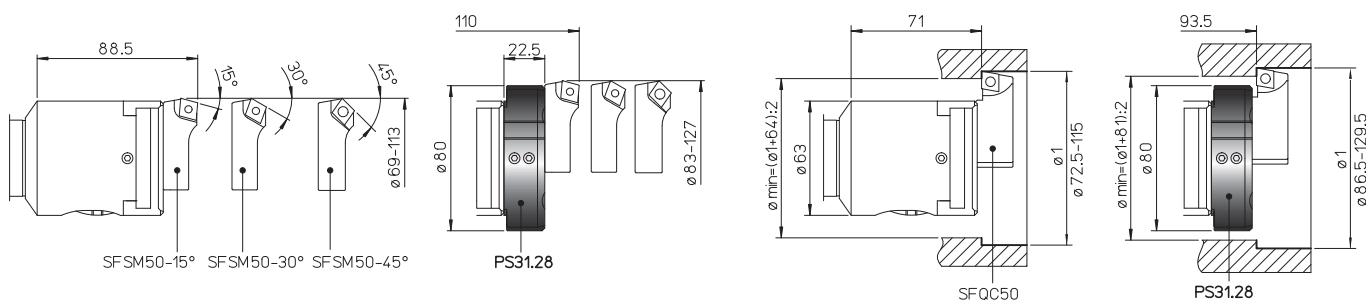

REF.	CODE	Ø1	L	L1	A	B	⚠	⚠	⚠	⚠	⚠	Kg.	
<b>SFTP 32</b>	470500532001				11.5	34.5			TPGX 0902..		CS 250T	TORX T08	0.02
<b>SFTP 50</b>	470500550001				19	52			TPGX 1103..		CS 300890T	TORX T08	0.08
<b>SFTP 51</b>	470500550003				21	52			TCMT 16T3..		TS 4	TORX T15	0.09
<b>SFCC 50</b>	470500550002				19	52			CCGT 09T3..		TS 4	TORX T15	0.08
<b>SFCC 51</b>	470500550004				21	52			CCMT 1204..		TS 5	TORX T25	0.09
<b>SFQC 50</b>	470500550062				20.5	53			CCMT 09T3..		TS 4	TORXT15	0.1
<b>SFSM 50-15°</b>	470500550011				19	50.5			CCMT 09T3..		TS 4	TORXT15	0.07
<b>SFSM 50-30°</b>	470500550013				19	50.5			CCMT 09T3..		TS 4	TORXT15	0.07
<b>SFSM 50-45°</b>	470500550015				19	50.5			CCMT 09T3..		TS 4	TORXT15	0.07
<b>B3.06</b>	572010506001	6 ~ 8	29	21					WCGT 0201..		TS 21	TORX T06	0.035
<b>B3.08</b>	572010508001	8 ~ 10	36	28					WCGT 0201..		TS 211	TORX T06	0.04
<b>B3.10</b>	572010510001	10 ~ 12	43	35					TPGX 0902..		CS 250 T	TORX T08	0.05
<b>B3.11</b>	572010511001	11 ~ 13	48	40					TPGX 0902..		CS 250 T	TORX T08	0.055
<b>B3.12</b>	572010512001	12 ~ 14	48	42					TPGX 0902..		CS 250 T	TORX T08	0.06
<b>B3.14</b>	572010514001	14 ~ 16	52	50					TPGX 0902..		CS 250 T	TORX T08	0.07
<b>B3.16</b>	572010516001	16 ~ 18	58	50					TPGX 0902..		CS 250 T	TORX T08	0.07
<b>B3.18</b>	572010518001	18 ~ 22	63						TPGX 0902..		CS 250 T	TORX T08	0.1
<b>B3.22</b>	572010522001	22 ~ 30	68						TPGX 0902..		CS 250 T	TORX T08	0.1
<b>B5.06</b>	572010506105	6 ~ 8	36						WCGT 0201..		TS 21	TORX T06	0.075
<b>B5.08</b>	572010508105	8 ~ 10	48						WCGT 0201..		TS 211	TORX T06	0.09
<b>B5.10</b>	572010510105	10 ~ 12	60						TPGX 0902..		CS 250 T	TORX T08	0.1
<b>B5.12</b>	572010512105	12 ~ 14	72						TPGX 0902..		CS 250 T	TORX T08	0.1
<b>B5.14</b>	572010514105	14 ~ 16	84						TPGX 0902..		CS 250 T	TORX T08	0.2
<b>B5.16</b>	572010516105	16 ~ 18	96						TPGX 0902..		CS 250 T	TORX T08	0.3
<b>B8.06</b>	572010506108	6 ~ 8	45						WCGT 0201..		TS 21	TORX T06	0.065
<b>B8.08</b>	572010508108	8 ~ 10	60						WCGT 0201..		TS 211	TORX T06	0.08
<b>B8.10</b>	572010510108	10 ~ 12	75						TPGX 0902..		CS 250 T	TORX T08	0.1
<b>B8.12</b>	572010512108	12 ~ 14	90						TPGX 0902..		CS 250 T	TORX T08	0.2
<b>B8.14</b>	572010514108	14 ~ 16	105						TPGX 0902..		CS 250 T	TORX T08	0.2
<b>B8.16</b>	572010516108	16 ~ 18	120						TPGX 0902..		CS 250 T	TORX T08	0.3





## P 22 Ø 40 ~ 90

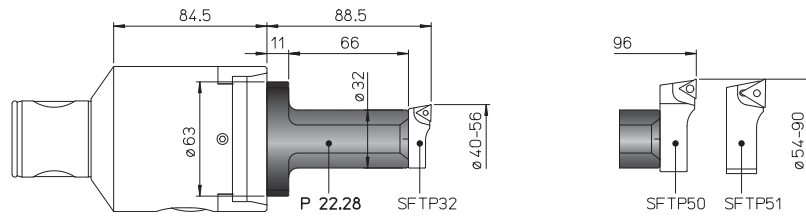

## PS Ø 88 ~ 200

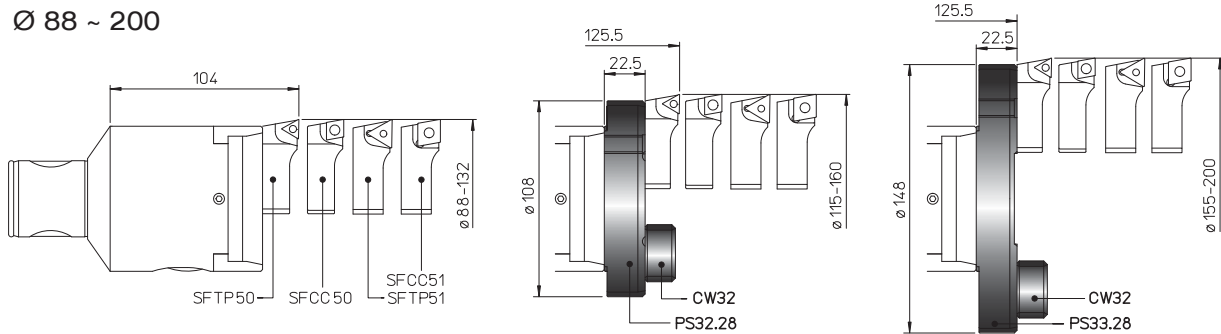

## PS Ø 85 ~ 202.5

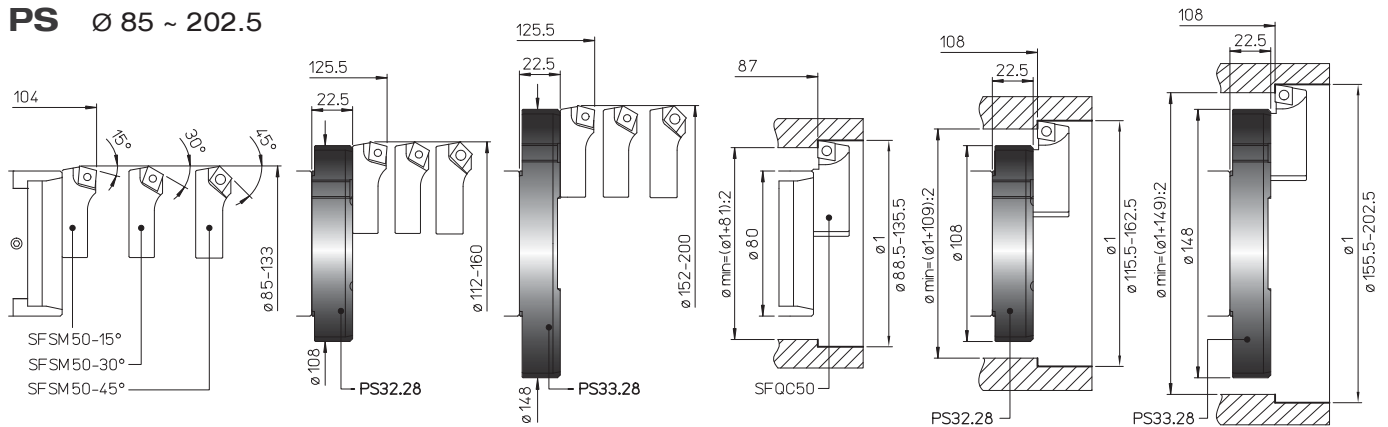

REF.	CODE	Ø1	L	L1	A	B						Kg.	
SFTP 32	470500532001				11.5	34.5			TPGX 0902..		CS 250T	TORX T08	0.02
SFTP 50	470500550001				19	52			TPGX 1103..		CS 300890T	TORX T08	0.08
SFTP 51	470500550003				21	52			TCMT 16T3..		TS 4	TORX T15	0.09
SFCC 50	470500550002				19	52			CCGT 09T3..		TS 4	TORX T15	0.08
SFCC 51	470500550004				21	52			CCMT 1204..		TS 5	TORX T25	0.09
SFQC 50	470500550062				20.5	53			CCMT 09T3..		TS 4	TORXT15	0.1
SFSM 50-15°	470500550011				19	50.5			CCMT 09T3..		TS 4	TORXT15	0.07
SFSM 50-30°	470500550013				19	50.5			CCMT 09T3..		TS 4	TORXT15	0.07
SFSM 50-45°	470500550015				19	50.5			CCMT 09T3..		TS 4	TORXT15	0.07
B3.06	572010506001	6 ~ 8	29	21					WCGT 0201..		TS 21	TORX T06	0.035
B3.08	572010508001	8 ~ 10	36	28					WCGT 0201..		TS 211	TORX T06	0.04
B3.10	572010510001	10 ~ 12	43	35					TPGX 0902..		CS 250 T	TORX T08	0.05
B3.11	572010511001	11 ~ 13	48	40					TPGX 0902..		CS 250 T	TORX T08	0.055
B3.12	572010512001	12 ~ 14	48	42					TPGX 0902..		CS 250 T	TORX T08	0.06
B3.14	572010514001	14 ~ 16	52	50					TPGX 0902..		CS 250 T	TORX T08	0.07
B3.16	572010516001	16 ~ 18	58	50					TPGX 0902..		CS 250 T	TORX T08	0.07
B3.18	572010518001	18 ~ 22	63						TPGX 0902..		CS 250 T	TORX T08	0.1
B3.22	572010522001	22 ~ 30	68						TPGX 0902..		CS 250 T	TORX T08	0.1
B5.06	572010506105	6 ~ 8	36						WCGT 0201..		TS 21	TORX T06	0.075
B5.08	572010508105	8 ~ 10	48						WCGT 0201..		TS 211	TORX T06	0.09
B5.10	572010510105	10 ~ 12	60						TPGX 0902..		CS 250 T	TORX T08	0.1
B5.12	572010512105	12 ~ 14	72						TPGX 0902..		CS 250 T	TORX T08	0.1
B5.14	572010514105	14 ~ 16	84						TPGX 0902..		CS 250 T	TORX T08	0.2
B5.16	572010516105	16 ~ 18	96						TPGX 0902..		CS 250 T	TORX T08	0.3
B8.06	572010506108	6 ~ 8	45						WCGT 0201..		TS 21	TORX T06	0.065
B8.08	572010508108	8 ~ 10	60						WCGT 0201..		TS 211	TORX T06	0.08
B8.10	572010510108	10 ~ 12	75						TPGX 0902..		CS 250 T	TORX T08	0.1
B8.12	572010512108	12 ~ 14	90						TPGX 0902..		CS 250 T	TORX T08	0.2
B8.14	572010514108	14 ~ 16	105						TPGX 0902..		CS 250 T	TORX T08	0.2
B8.16	572010516108	16 ~ 18	120						TPGX 0902..		CS 250 T	TORX T08	0.3

## TRC 32 HS

### TRM 32 HSB Ø 2.5 ~ 18

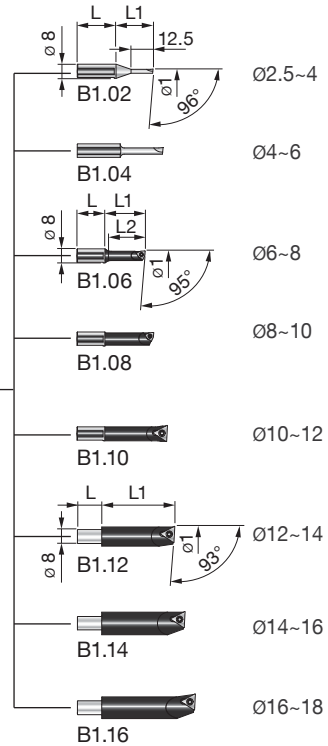
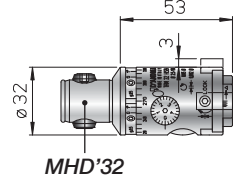
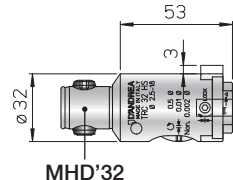

REF.	CODE	Ø	Kg.
TRC 32 HS	455033200531	2.5 ~ 18	0.35
TRM 32 HSB	455103200531	2.5 ~ 18	0.35

## KIT K01 TRC 32 HS Ø 2.5 ~ 12

REF.	CODE	Ø	Kg.
KIT K01 TRC 32 HS	655033230322	2.5 ~ 12	1

## KIT K01 TRM 32 HSB Ø 2.5 ~ 12

REF.	CODE	Ø	Kg.
KIT K01 TRM 32 HSB	655003230321	2.5 ~ 12	1



- 1 TRC 32 HS
- 1 B1.02
- 1 B1.04
- 1 B1.06
- 1 B1.08
- 1 B1.10
- 5 TPGX 090202L DC100
- 2 WCGT 020102L DC100

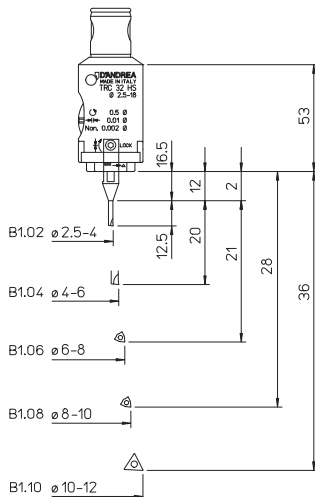

- 1 TRM 32 HSB
- 1 B1.02
- 1 B1.04
- 1 B1.06
- 1 B1.08
- 1 B1.10
- 5 TPGX 090202L DC100
- 2 WCGT 020102L DC100

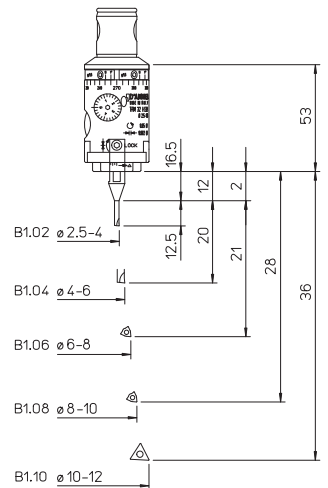

REF.	CODE	Ø1	L	L1	⊖	⊕	⊗	⊘	Kg.
B1.02	572010502001	2.5 ~ 4	22	21					0.02
B1.04	572010504001	4 ~ 6	24	24					0.02
B1.06	572010506000	6 ~ 8	16	23	WCGT 0201..		TS 21	TORX T06	0.01
B1.08	572010508000	8 ~ 10	16	28	WCGT 0201..		TS 211	TORX T06	0.015
B1.10	572010510000	10 ~ 12	16	36		TPGX 0902..	CS 250 T	TORX T08	0.02
B1.12	572010512000	12 ~ 14	14	42		TPGX 0902..	CS 250 T	TORX T08	0.03
B1.14	572010514000	14 ~ 16	14	48		TPGX 0902..	CS 250 T	TORX T08	0.04
B1.16	572010516000	16 ~ 18	14	54		TPGX 0902..	CS 250 T	TORX T08	0.05

# TRC HS ALTA VELOCITA' - TRM HSB BILANCIABILI *testarossa*

## TRC 50 HS TRM 50 HSB Ø 2.5 ~ 22

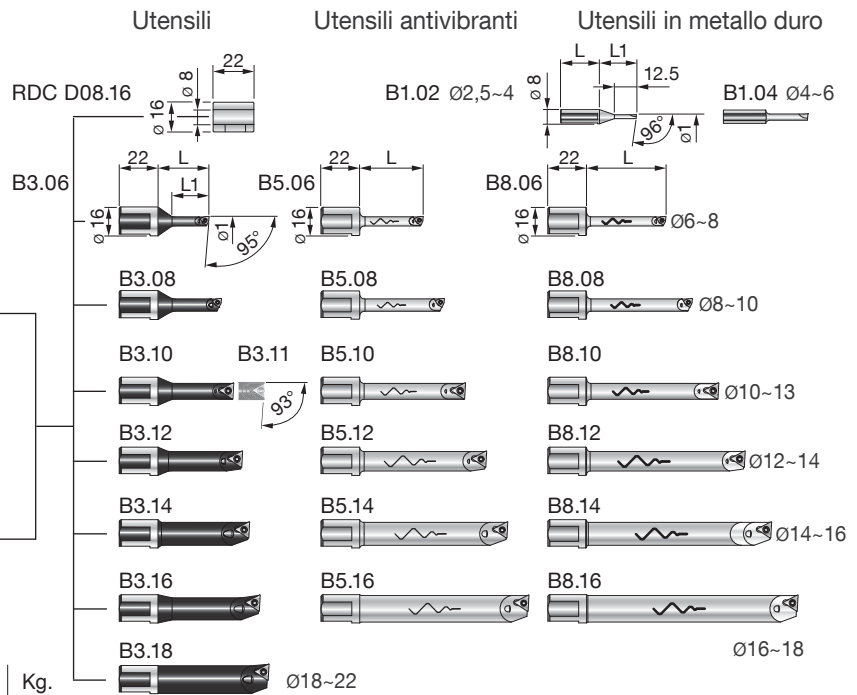
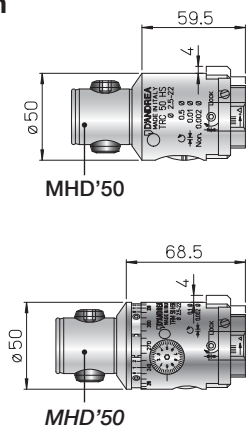

REF.	CODE	Ø	Kg.
TRC 50 HS	455035000601	2.5 ~ 22	1
TRM 50 HSB	455105000701	2.5 ~ 22	1.4

REF.	CODE	Kg.
RDC D08.16	200560116082	0.02

## KIT K01 TRC 50 HS Ø 6 ~ 22

REF.	CODE	Ø	Kg.
KIT K01 TRC 50 HS	655035030502	6 ~ 22	1.8

## KIT K01 TRM 50 HSB Ø 6 ~ 22

REF.	CODE	Ø	Kg.
KIT K01 TRM 50 HSB	655005030501	6 ~ 22	2.1



- 1 TRM 50 HSB
- 1 B3.06
- 1 B3.08
- 1 B3.10
- 1 B3.12
- 1 B3.14
- 1 B3.16
- 1 B3.18
- 5 TPGX 090202L DC100
- 2 WCGT 020102L DC100

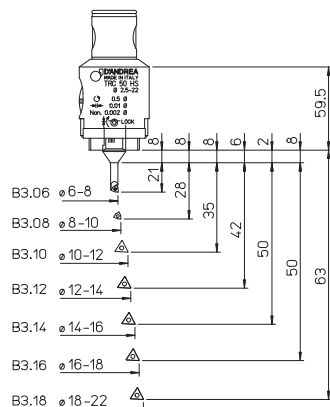

- 1 TRM 50 HSB
- 1 B3.06
- 1 B3.08
- 1 B3.10
- 1 B3.12
- 1 B3.14
- 1 B3.16
- 1 B3.18
- 5 TPGX 090202L DC100
- 2 WCGT 020102L DC100

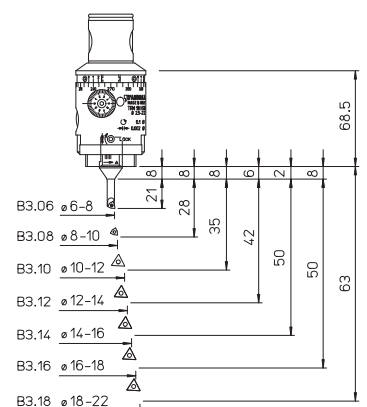

REF.	CODE	Ø1	L	L1	⚠	⚠	🔧	🔧	Kg.
B1.02	572010502001	2.5 - 4	22	21					0.02
B1.04	572010504001	4 - 6	24	24					0.02
B3.06	572010506001	6 - 8	29	21	WCGT 0201..		TS 21	TORX T06	0.035
B3.08	572010508001	8 ~ 10	36	28	WCGT 0201..		TS 211	TORX T06	0.04
B3.10	572010510001	10 ~ 12	43	35		TPGX 0902..	CS 250 T	TORX T08	0.05
B3.11	572010511001	11 ~ 13	48	40		TPGX 0902..	CS 250 T	TORX T08	0.055
B3.12	572010512001	12 ~ 14	48	42		TPGX 0902..	CS 250 T	TORX T08	0.06
B3.14	572010514001	14 ~ 16	52	50		TPGX 0902..	CS 250 T	TORX T08	0.07
B3.16	572010516001	16 ~ 18	58	50		TPGX 0902..	CS 250 T	TORX T08	0.07
B3.18	572010518001	18 ~ 22	63			TPGX 0902..	CS 250 T	TORX T08	0.1
B5.06	572010506105	6 - 8	36		WCGT 0201..		TS 21	TORX T06	0.075
B5.08	572010508105	8 ~ 10	48		WCGT 0201..		TS 211	TORX T06	0.09
B5.10	572010510105	10 ~ 12	60			TPGX 0902..	CS 250 T	TORX T08	0.1
B5.12	572010512105	12 ~ 14	72			TPGX 0902..	CS 250 T	TORX T08	0.1
B5.14	572010514105	14 ~ 16	84			TPGX 0902..	CS 250 T	TORX T08	0.2
B5.16	572010516105	16 ~ 18	96			TPGX 0902..	CS 250 T	TORX T08	0.3
B8.06	572010506108	6 - 8	45		WCGT 0201..		TS 21	TORX T06	0.065
B8.08	572010508108	8 ~ 10	60		WCGT 0201..		TS 211	TORX T06	0.08
B8.10	572010510108	10 ~ 12	75			TPGX 0902..	CS 250 T	TORX T08	0.1
B8.12	572010512108	12 ~ 14	90			TPGX 0902..	CS 250 T	TORX T08	0.2
B8.14	572010514108	14 ~ 16	105			TPGX 0902..	CS 250 T	TORX T08	0.2
B8.16	572010516108	16 ~ 18	120			TPGX 0902..	CS 250 T	TORX T08	0.3

## TRE 32 MHD' Ø 35.5 ~ 51.5



2 µm

REF.	CODE	Ø	Kg.
TRE 32 MHD'32 69K	455200320321 •	35.5 ~ 51.5	0.4

• Salvo disponibilità magazzino

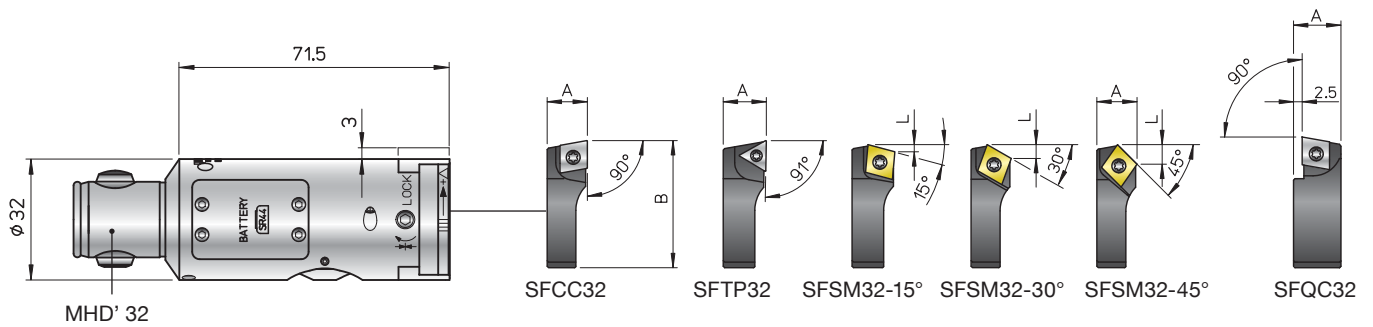

REF.	CODE	A	B	L					Kg.
SFCC 32	470500532002	11.5	34.5		CCGT 0602..		TS 25	TORX T08	0.02
SFTP 32	470500532001	11.5	34.5			TPGX 0902..	CS 250T	TORX T08	0.02
SFQC 32	470500532062	13.5	35.5		CCMT 0602..		TS 25	TORX T08	0.03
SFSM 32-15°	470500532011	11.5	33.5	1.6	CCMT 0602..		TS 25	TORX T08	0.02
SFSM 32-30°	470500532013	11.5	33.5	3	CCMT 0602..		TS 25	TORX T08	0.02
SFSM 32-45°	470500532015	11.5	33.5	4.3	CCMT 0602..		TS 25	TORX T08	0.02

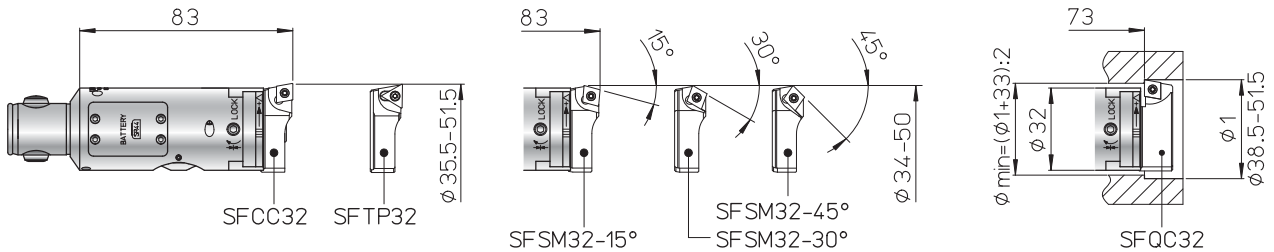



TRE 40 MHD' Ø 48 ~ 64



2 μm

REF.	CODE	Ø	Kg.
TRE 40 MHD'40 69K	455200400401 •	48 ~ 64	0.7

• Salvo disponibilità magazzino

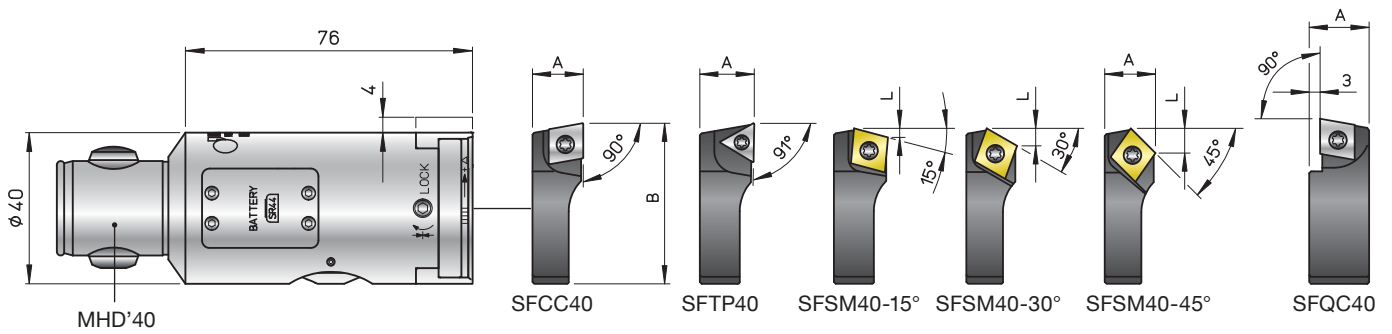

REF.	CODE	A	B	L					Kg.
SFCC 40	470500540002	14	44		CCGT 09T3..		TS 4	TORX T15	0.04
SFTP 40	470500540001	14	44			TPGX 1103..	CS 300890T	TORX T08	0.04
SFQC 40	470500540062	16.5	46		CCMT 09T3..		TS 4	TORXT15	0.06
SFSM 40-15°	470500540011	14	42.5	2.4	CCMT 09T3..		TS 4	TORXT15	0.03
SFSM 40-30°	470500540013	14	42.5	4.6	CCMT 09T3..		TS 4	TORXT15	0.03
SFSM 40-45°	470500540015	14	42.5	6.6	CCMT 09T3..		TS 4	TORXT15	0.03

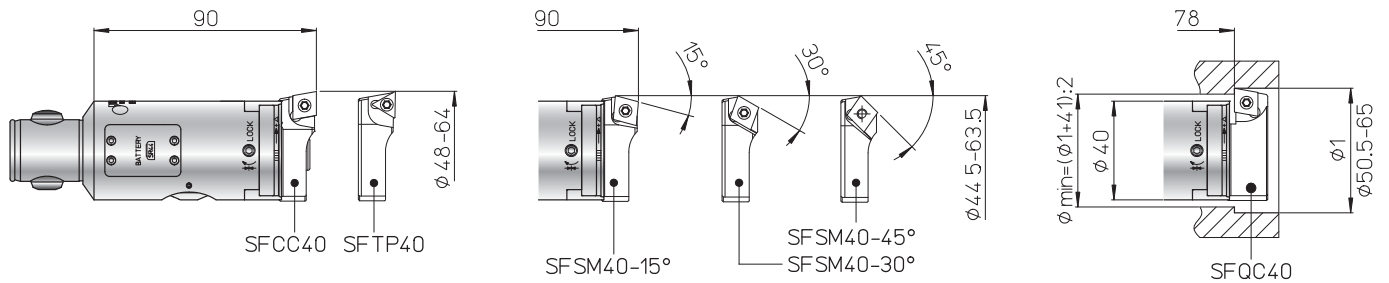

## TRE 50 MHD' Ø 2.5 ~ 110

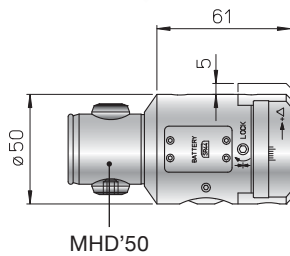

REF.	CODE	Kg.
TRE 50 MHD'50 69K	455200500501	1.1
RDC D08.16	200560116082	0.02
P25.63 TR..	435116250631	0.5
P25.105 TR..	435116251051	0.8
PS 31.24 TR..50	433024140751	0.19
CW 32	392011003201	0.07

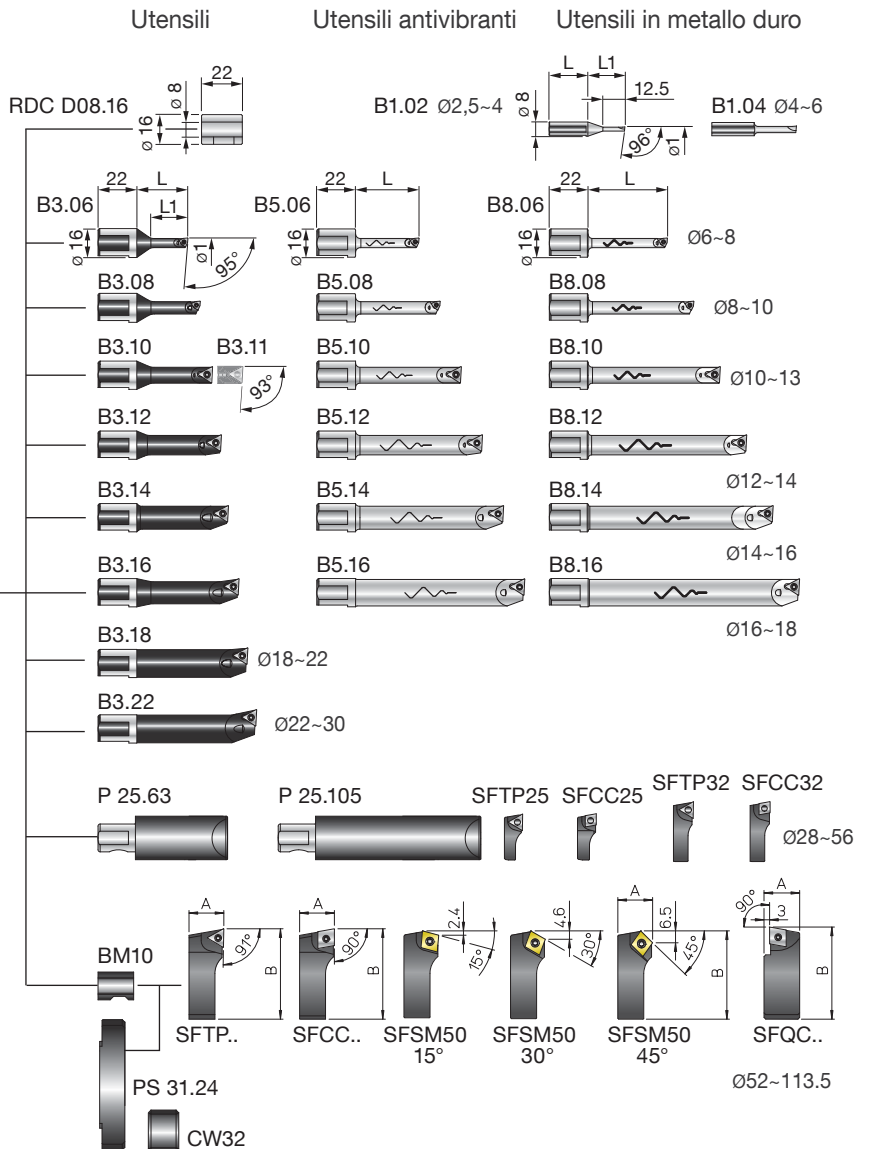

## KIT K01 Ø 6 ~ 110

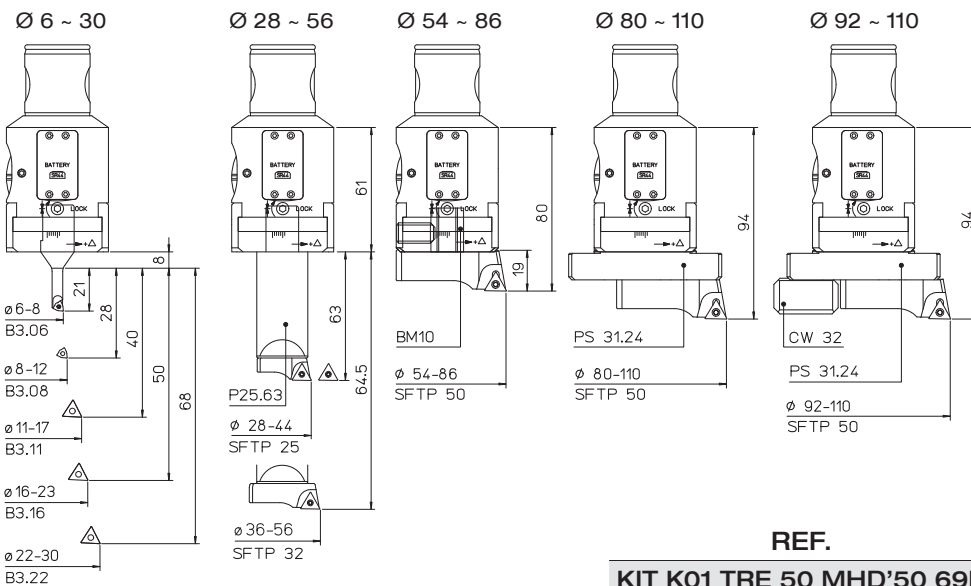

- 1 TRE 50 MHD'50
- 1 BM10
- 1 P25.63
- 1 PS 31.24
- 1 CW 32
- 1 B3.06
- 1 B3.08
- 1 B3.11
- 1 B3.16
- 1 B3.22
- 1 SFTP25
- 1 SFTP32
- 1 SFTP50
- 5 TPGX 090202L DC100
- 1 TPGX 110302L DC100
- 2 WCGT 020102L DC100

REF.	CODE	Ø	Kg
KIT K01 TRE 50 MHD'50 69K	655200500502	6 ~ 110	3.1

## P 25 Ø 28 ~ 56

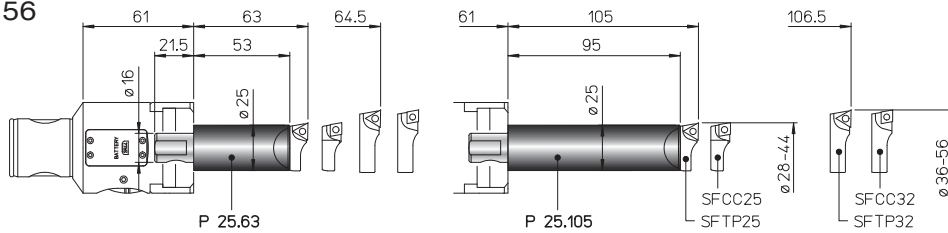

## PS 31.24 Ø 54 ~ 110

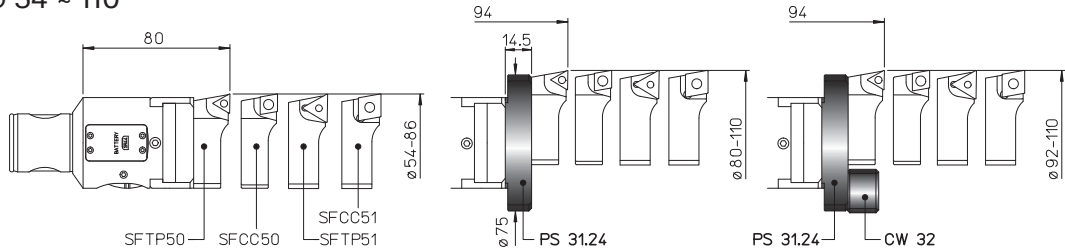

## PS 31.24 Ø 52 ~ 113.5

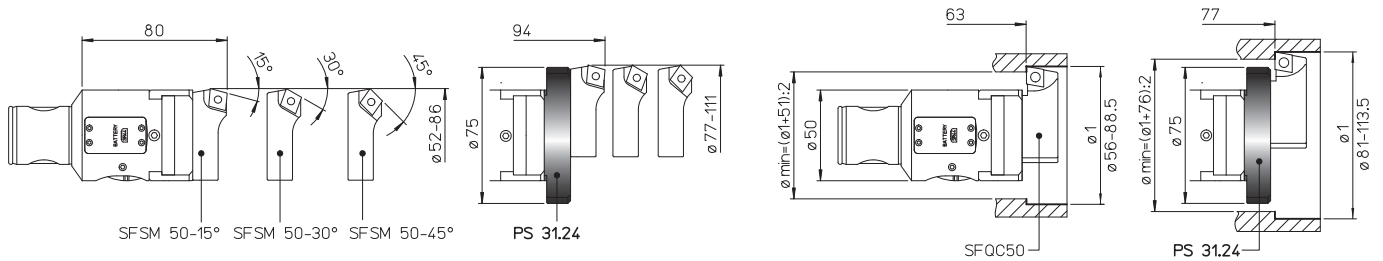

REF.	CODE	Ø1	L	L1	A	B							Kg.
SFTP 25	470500525001				10	26.5		TPGX 0902..		CS 250T	TORX T08		0.01
SFTP 32	470500532001				11.5	34.5		TPGX 0902..		CS 250T	TORX T08		0.02
SFTP 50	470500550001				19	52		TPGX 1103..		CS 300890T	TORX T08		0.08
SFTP 51	470500550003				21	52		TCMT 16T3..		TS 4	TORX T15		0.09
SFCC 25	470500525002				10	26.5		CCGT 0602..		TS 25	TORX T08		0.01
SFCC 32	470500532002				11.5	34.5		CCGT 0602..		TS 25	TORX T08		0.02
SFCC 50	470500550002				19	52		CCGT 09T3..		TS 4	TORX T15		0.08
SFCC 51	470500550004				21	52		CCMT 1204..		TS 5	TORX T25		0.09
SFQC 50	470500550062				20.5	53		CCMT 09T3..		TS 4	TORX T15		0.1
SFSM 50-15°	470500550011				19	50.5		CCMT 09T3..		TS 4	TORX T15		0.07
SFSM 50-30°	470500550013				19	50.5		CCMT 09T3..		TS 4	TORX T15		0.07
SFSM 50-45°	470500550015				19	50.5		CCMT 09T3..		TS 4	TORX T15		0.07
B1.02	572010502001	2.5 ~ 4	22	21									0.02
B1.04	572010504001	4 ~ 6	24	24									0.02
B3.06	572010506001	6 ~ 8	29	21			WCGT 0201..			TS 21	TORX T06		0.035
B3.08	572010508001	8 ~ 10	36	28			WCGT 0201..			TS 211	TORX T06		0.04
B3.10	572010510001	10 ~ 12	43	35			TPGX 0902..			CS 250 T	TORX T08		0.05
B3.11	572010511001	11 ~ 13	48	40			TPGX 0902..			CS 250 T	TORX T08		0.055
B3.12	572010512001	12 ~ 14	48	42			TPGX 0902..			CS 250 T	TORX T08		0.06
B3.14	572010514001	14 ~ 16	52	50			TPGX 0902..			CS 250 T	TORX T08		0.07
B3.16	572010516001	16 ~ 18	58	50			TPGX 0902..			CS 250 T	TORX T08		0.07
B3.18	572010518001	18 ~ 22	63				TPGX 0902..			CS 250 T	TORX T08		0.1
B3.22	572010522001	22 ~ 30	68				TPGX 0902..			CS 250 T	TORX T08		0.1
B5.06	572010506105	6 ~ 8	36				WCGT 0201..			TS 21	TORX T06		0.075
B5.08	572010508105	8 ~ 10	48				WCGT 0201..			TS 211	TORX T06		0.09
B5.10	572010510105	10 ~ 12	60				TPGX 0902..			CS 250 T	TORX T08		0.1
B5.12	572010512105	12 ~ 14	72				TPGX 0902..			CS 250 T	TORX T08		0.1
B5.14	572010514105	14 ~ 16	84				TPGX 0902..			CS 250 T	TORX T08		0.2
B5.16	572010516105	16 ~ 18	96				TPGX 0902..			CS 250 T	TORX T08		0.3
B8.06	572010506108	6 ~ 8	45				WCGT 0201..			TS 21	TORX T06		0.065
B8.08	572010508108	8 ~ 10	60				WCGT 0201..			TS 211	TORX T06		0.08
B8.10	572010510108	10 ~ 12	75				TPGX 0902..			CS 250 T	TORX T08		0.1
B8.12	572010512108	12 ~ 14	90				TPGX 0902..			CS 250 T	TORX T08		0.2
B8.14	572010514108	14 ~ 16	105				TPGX 0902..			CS 250 T	TORX T08		0.2
B8.16	572010516108	16 ~ 18	120				TPGX 0902..			CS 250 T	TORX T08		0.3

TRE 63 MHD' Ø 6 ~ 125



2 µm

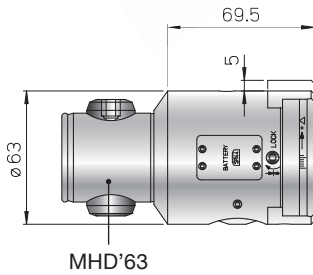

Utensili

Utensili antivibranti

Utensili in metallo duro

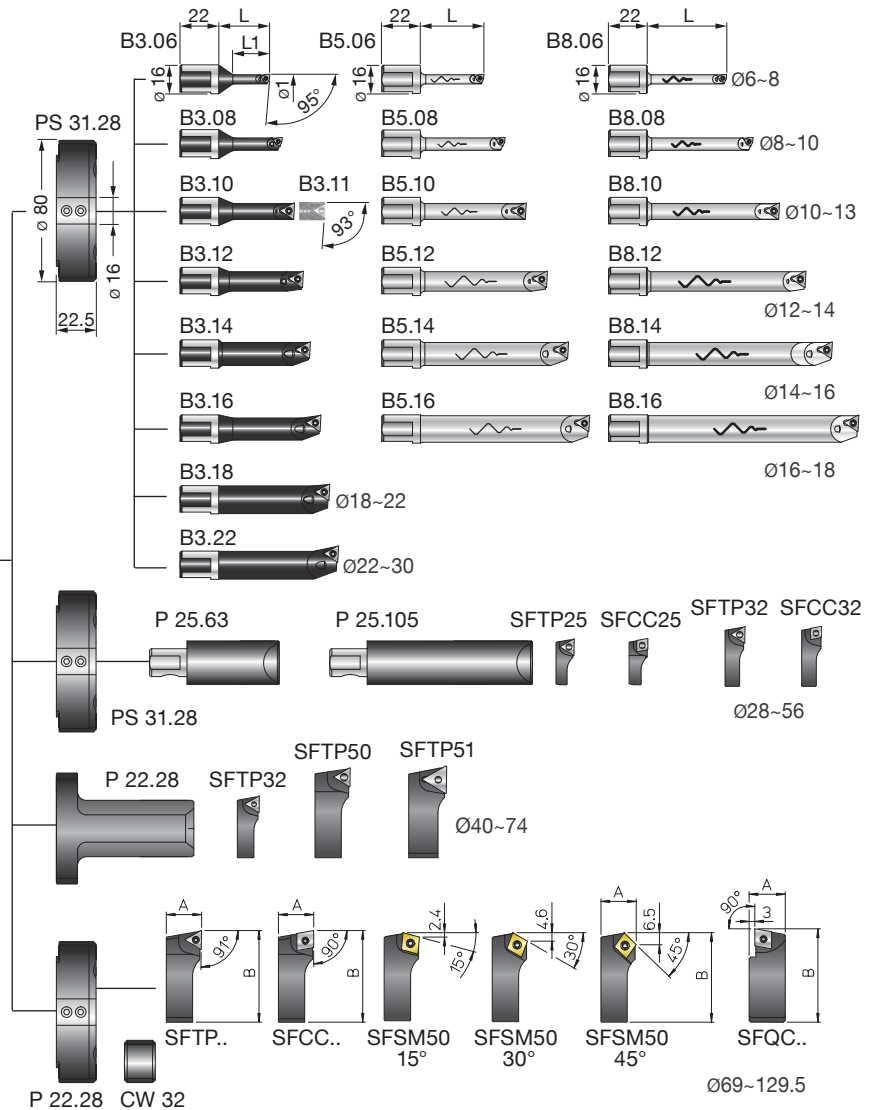

REF.	CODE	Kg.
TRE 63 MHD'63 69K	455200630631	2.2
P 22.28	433028220631	0.45
P25.63 TR..	435116250631	0.5
P25.105 TR..	435116251051	0.8
PS 31.28 TRE 63	433028220802	0.3
CW 32	392011003201	0.07

KIT K01 Ø 6 ~ 125

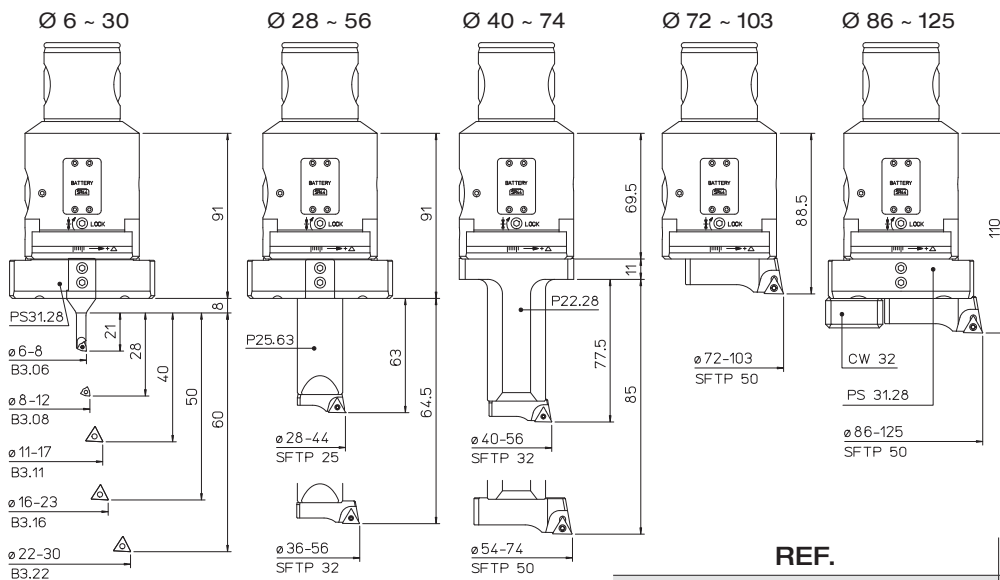

- 1 TRE 63 MHD'63
- 1 P25.63
- 1 P22.28
- 1 PS31.28
- 1 CW 32
- 1 B3.06
- 1 B3.08
- 1 B3.11
- 1 B3.16
- 1 B3.22
- 1 SFTP32
- 1 SFTP50
- 5 TPGX 090202L DC100
- 1 TPGX 110302L DC100
- 2 WCGT 020102L DC100

REF.	CODE	Ø	Kg.
KIT K01 TRE 63 MHD'63 69K	655200500631	6 ~ 125	4.7





TRE 80 MHD' Ø 6 ~ 200

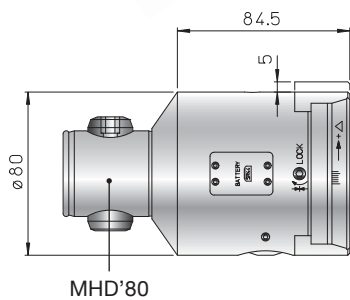

MHD'80

Utensili      Utensili antivibranti      Utensili in metallo duro

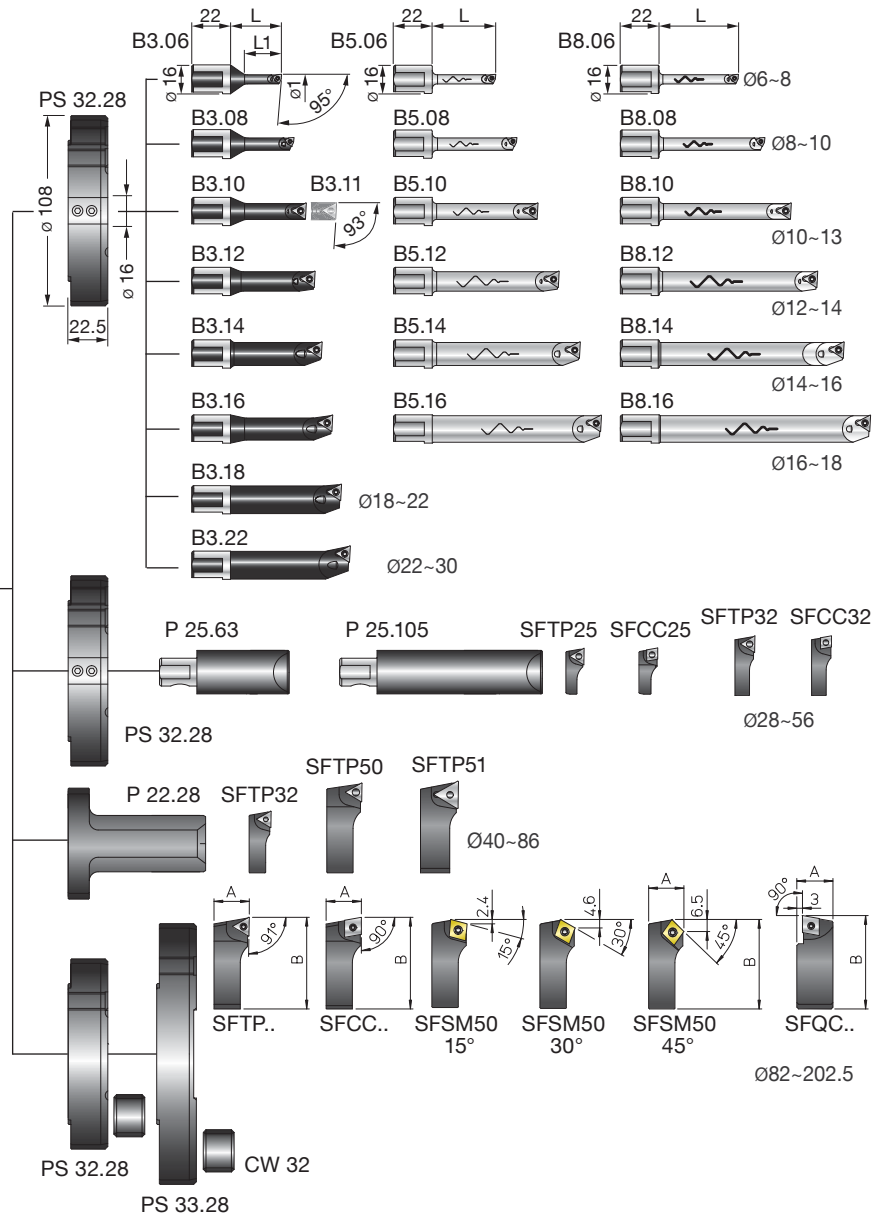

REF.	CODE	Kg.
TRE80 MHD'80 69K	455200800801	3.9
P 22.28	433028220631	0.45
P25.63 TR..	435116250631	0.5
P25.105 TR..	435116251051	0.8
PS 32.28 TRE 80	433028221082	0.5
PS 33.28 TRE 80	433028221482	0.6
CW 32	392011003201	0.07

KIT K01 Ø 6 ~ 200

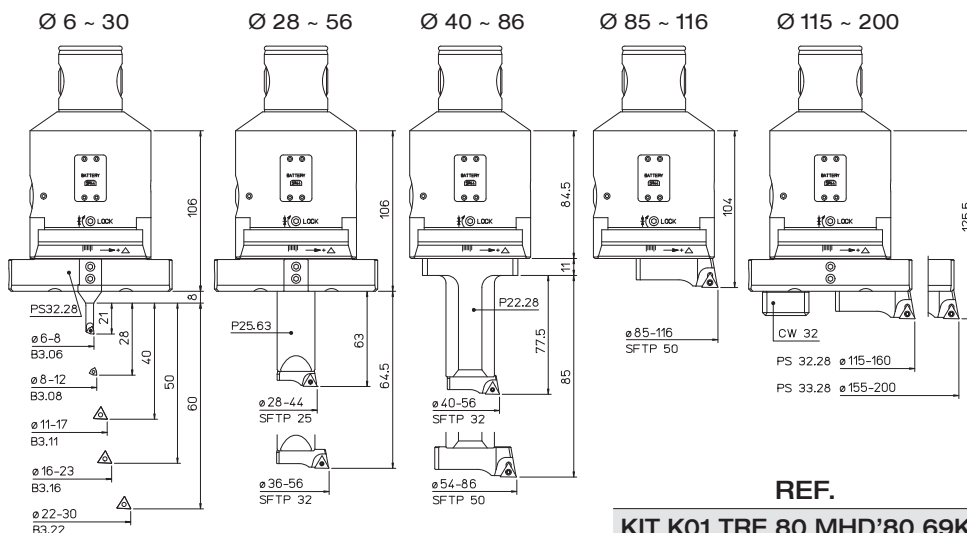

- 1 TRE 80 MHD'80
- 1 PS25.63
- 1 PS32.28
- 1 PS33.28
- 1 CW 32
- 1 P22.28
- 1 B3.06
- 1 B3.08
- 1 B3.11
- 1 B3.16
- 1 B3.22
- 1 SFTP32
- 1 SFTP50
- 5 TPGX 090202L DC100
- 1 TPGX 110302L DC100
- 2 WCGT 020102L DC100

REF.	CODE	Ø	Kg.
KIT K01 TRE 80 MHD'80 69K	655200500801	6 ~ 200	7.1



**BPS** Ø 200 ~ 1200

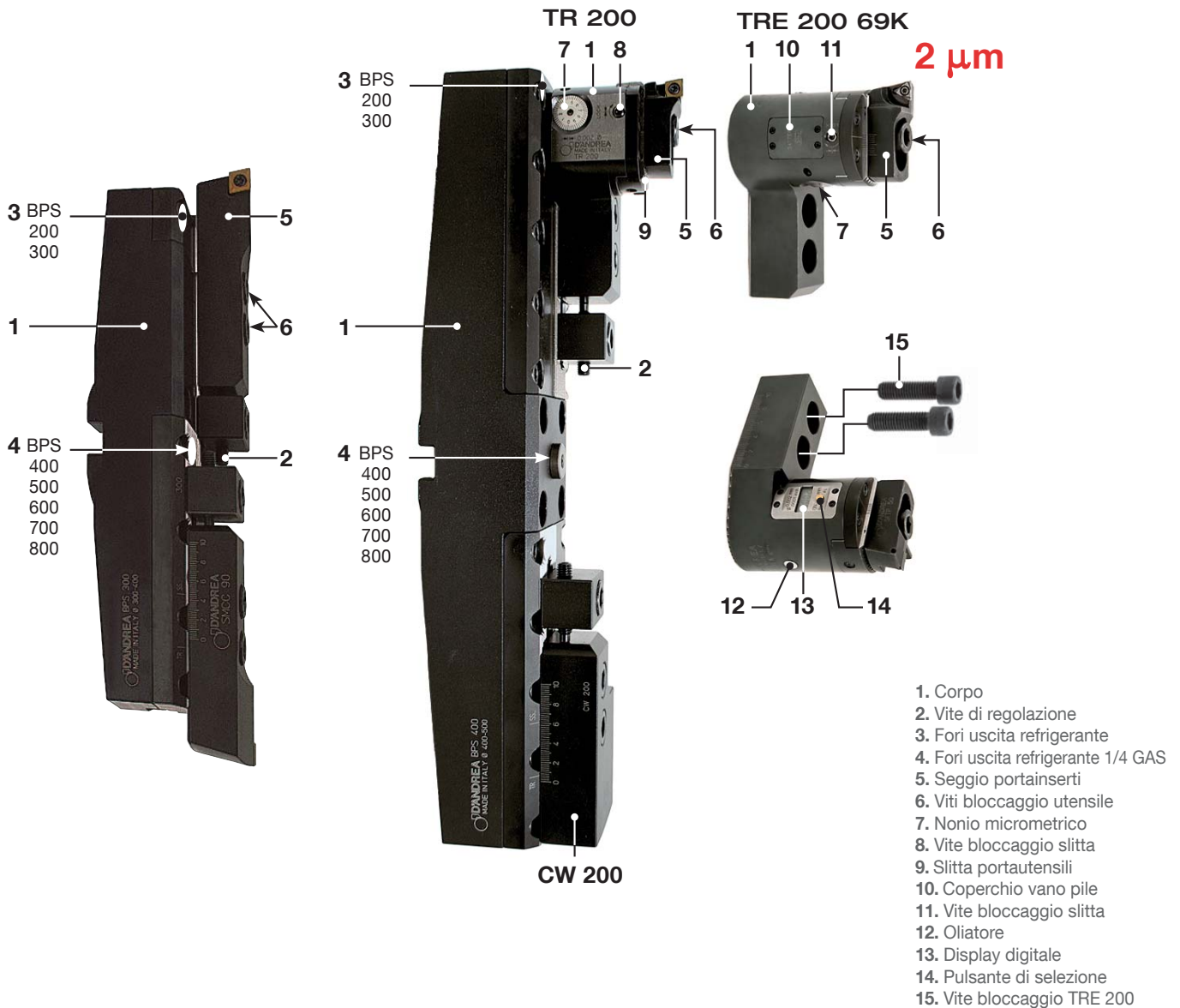

Le barre **BPS** coprono un campo di lavoro da Ø 200 a Ø 1200 mm, sia in sgrossatura che in finitura.  
L'ampia gamma di accessori comprende sia sedgi di sgrossatura che testine micrometriche di finitura in grado di eseguire operazioni di alesatura, smussi e lavorazioni in sottosquadra.  
Il corpo principale delle barre **BPS** è costruito in alluminio sul quale vengono fissate le piastre portaseggio in acciaio.

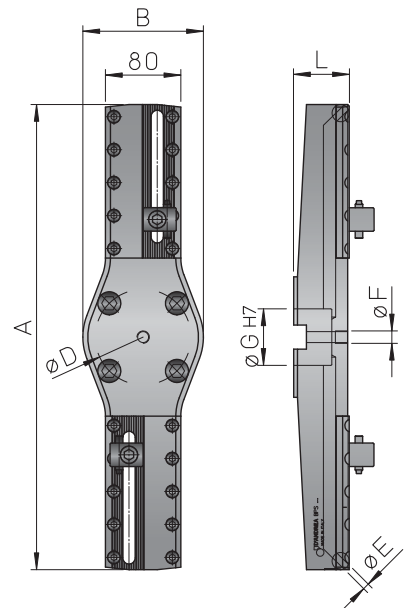

REF.	CODE	Ø	A	B	Ø D	Ø E	Ø F	Ø G	L	Kg.
<b>BPS 200</b>	435540881980	200 ~ 600	194	(4xM12)	66.7	2.5		40	54	3.2
<b>BPS 300</b>	435540882980	300 ~ 700	288	(4xM12)	66.7	2.5		40	54	3.9
<b>BPS 400</b>	435540883980	400 ~ 800	394	(4xM12)	66.7	1/4 GAS		40	61	6.9
<b>BPS 500</b>	435560884940	500 ~ 900	494	128 (4xM16)	101.6	1/4 GAS		60	69	9.4
<b>BPS 600</b>	435560885940	600 ~ 1000	594	128 (4xM16)	101.6	1/4 GAS		60	71	9.9
<b>BPS 700</b>	435560886940 •	700 ~ 1100	694	128 (4xM16)	101.6	1/4 GAS		60	74	11.2
<b>BPS 800</b>	435560887940 •	800 ~ 1200	794	128 (4xM16)	101.6	1/4 GAS		60	80	15.2

• Salvo disponibilità magazzino

BPS Ø 200 ~ 1200

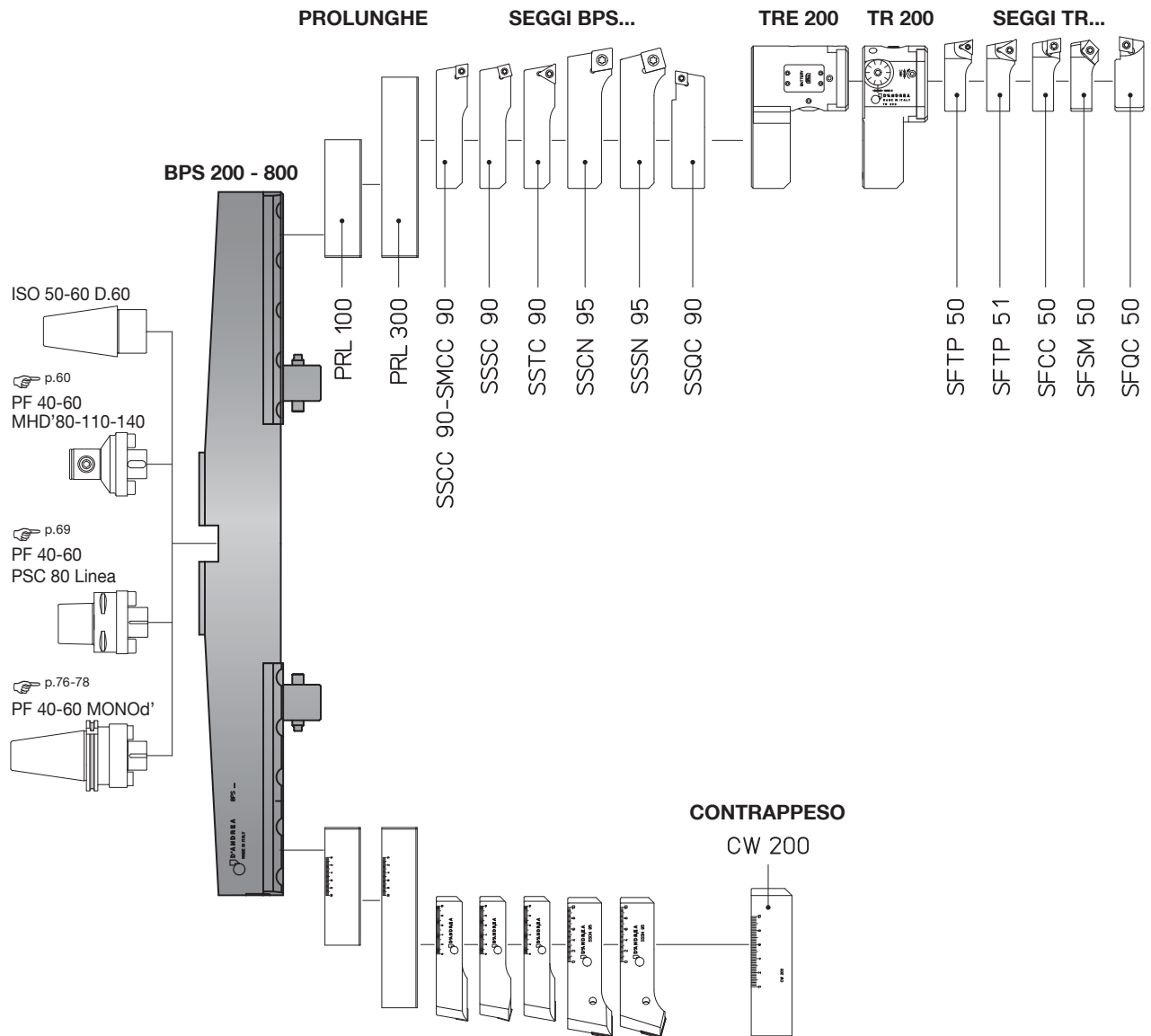

## ISO 50-60 D.60

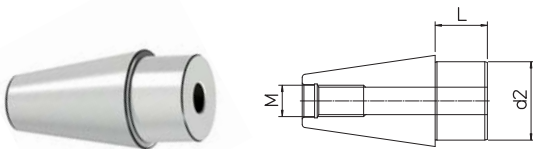

REF.	CODE	d2	L	M	Kg.
ISO 50 D.60	71ISO-50-DC6040 •	60	40	24	4.8
ISO 60 D.60	71ISO-60-DC6040 •	60	40	30	9.7

• Salvo disponibilità magazzino

## PRL PROLUNGHE

## CW CONTRAPPESO

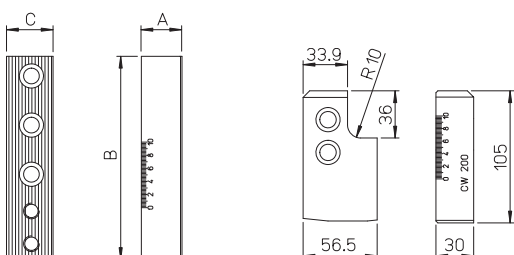

REF.	CODE	A	B	C	Kg.
PRL 100	392011015501	31	155	33.5	1.1
PRL 300	392011030001	41	255	35.5	2.8
CW 200	392011010501				1.3

## BPS Ø 200 ~ 1200

## SGROSSATURA

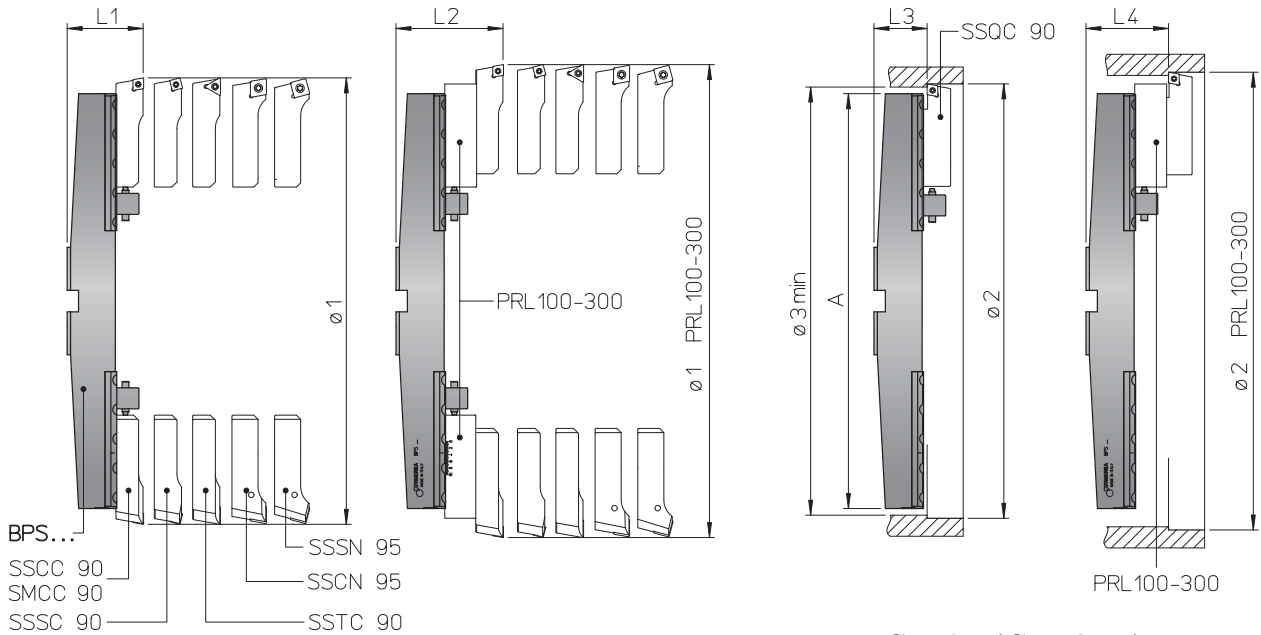

$$\text{Ø 3 min} = (\text{Ø 2} + \text{A} + 1) : 2$$

	BPS 200	BPS 300	BPS 400	BPS 500	BPS 600	BPS 700	BPS 800
A	194	298	394	494	594	694	794
Ø 1	200 ~ 300	300 ~ 400	400 ~ 500	500 ~ 600	600 ~ 700	700 ~ 800	800 ~ 900
Ø 1 PRL 100	300 ~ 400	400 ~ 500	500 ~ 600	600 ~ 700	700 ~ 800	800 ~ 900	900 ~ 1000
Ø 1 PRL 300	400 ~ 600	500 ~ 700	600 ~ 800	700 ~ 900	800 ~ 1000	900 ~ 1100	1000 ~ 1200
Ø 2	202 ~ 302	302 ~ 402	402 ~ 502	502 ~ 602	602 ~ 702	702 ~ 802	802 ~ 902
Ø 2 PRL 100	302 ~ 402	402 ~ 502	502 ~ 602	602 ~ 702	702 ~ 802	802 ~ 902	902 ~ 1002
Ø 2 PRL 300	402 ~ 602	502 ~ 702	602 ~ 802	702 ~ 902	802 ~ 1002	902 ~ 1102	1002 ~ 1202
L1 S... 90	86	86	93	101	103	106	112
L1 S... 95	94	94	101	109	111	114	120
L2 PRL 100 S... 90	116	116	123	131	133	136	142
L2 PRL 300 S... 90	126	126	133	141	143	146	152
L2 PRL 100 S... 95	124	124	131	139	141	144	150
L2 PRL 300 S... 95	134	134	141	149	151	154	160
L3 SSQC 90	56.5	56.5	63.5	71.5	73.5	76.5	82.5
L4 PRL 100 SSQC 90	86.5	86.5	93.5	101.5	103.5	106.5	112.5
L4 PRL 300 SSQC 90	96.5	96.5	103.5	111.5	113.5	116.5	122.5

## SEGGI SSC.. - SMCC .. - SSS .. - SSTC .. - SSQC ..

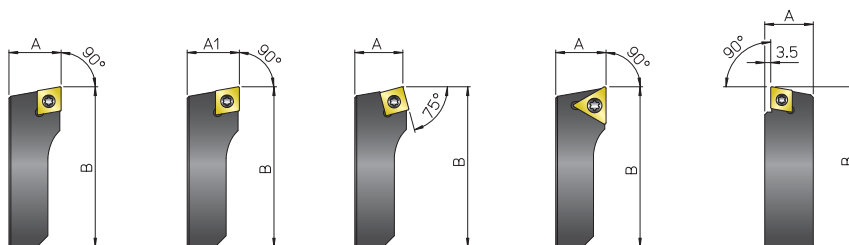

REF.	CODE	A	A1	B						Kg.
SSCC 90	470500590201	32	130	CCMT 1204..				TS 5	TORX T25	0.7
SSCN 95	470500595201	40	130	CNM. 1906..					<b>p. 89</b>	0.9
SMCC 90	470500590203		31.7	130	CCMT 1204..			TS 5	TORX T25	0.7
SSSC 90	470500590202	32	130		SCMT 1204..			TS 5	TORX T25	0.7
SSSN 95	470500595202	40	130		SNM . 1906..				<b>p. 89</b>	0.9
SSTC 90	470500590206	32	130			TCMT 2204..		TS 5	TORX T25	0.7



BPS Ø 200 ~ 1200

FINITURA

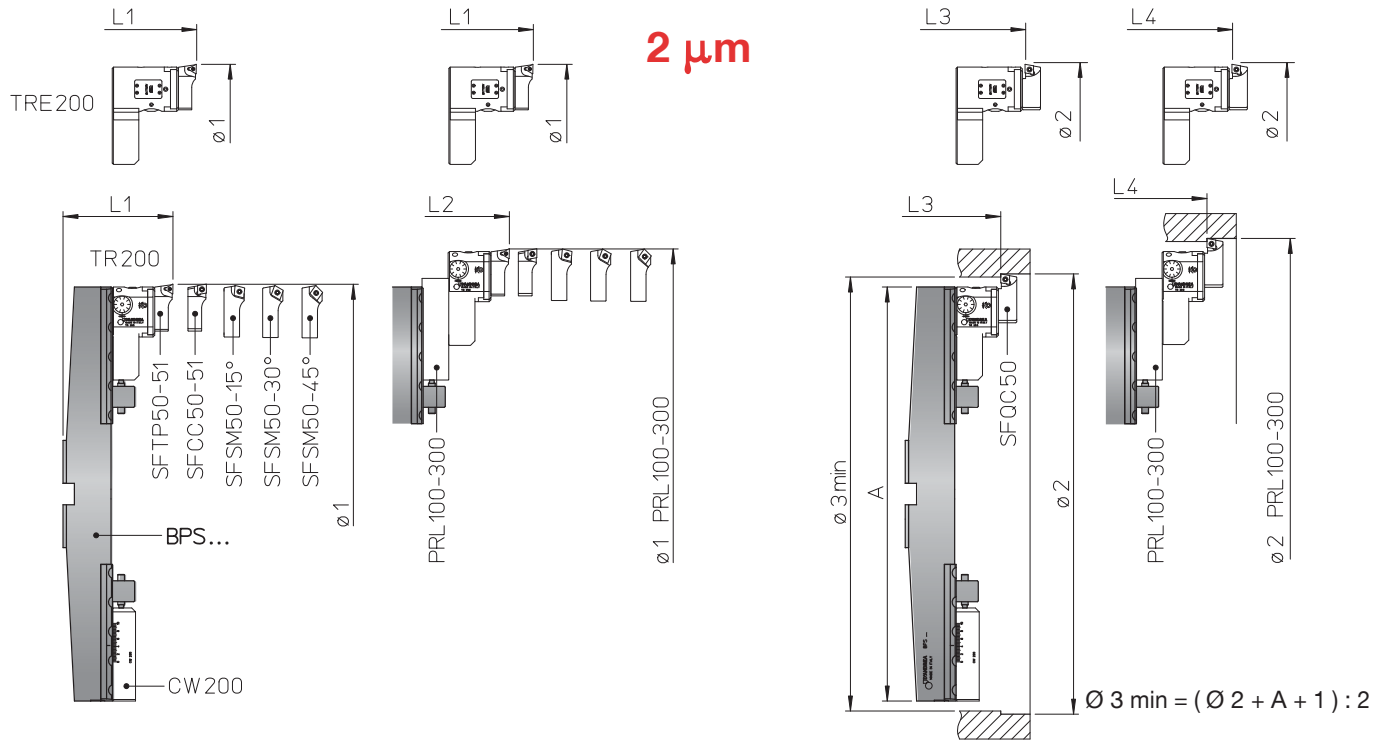

	BPS 200		BPS 300		BPS 400		BPS 500		BPS 600		BPS 700		BPS 800	
A	194		298		394		494		594		694		794	
Ø 1	200 ~ 300		300 ~ 400		400 ~ 500		500 ~ 600		600 ~ 700		700 ~ 800		800 ~ 900	
Ø 1 PRL 100	300 ~ 400		400 ~ 500		500 ~ 600		600 ~ 700		700 ~ 800		800 ~ 900		900 ~ 1000	
Ø 1 PRL 300	400 ~ 600		500 ~ 700		600 ~ 800		700 ~ 900		800 ~ 1000		900 ~ 1100		1000 ~ 1200	
Ø 2	202 ~ 302		302 ~ 402		402 ~ 502		502 ~ 602		602 ~ 702		702 ~ 802		802 ~ 902	
Ø 2 PRL 100	302 ~ 402		402 ~ 502		502 ~ 602		602 ~ 702		702 ~ 802		802 ~ 902		902 ~ 1002	
Ø 2 PRL 300	402 ~ 602		502 ~ 702		602 ~ 802		702 ~ 902		802 ~ 1002		902 ~ 1102		1002 ~ 1202	
L	TR200	TRE200	TR200	TRE200	TR200	TRE200	TR200	TRE200	TR200	TRE200	TR200	TRE200	TR200	TRE200
L1	120	147	120	147	127	154	135	162	137	164	140	167	146	173
L2 PRL 100	150	177	150	177	157	184	165	192	167	194	170	197	176	203
L2 PRL 300	160	187	160	187	167	194	175	202	177	204	180	207	186	213
L3	103	130	103	130	110	137	118	145	120	147	123	150	129	156
L4 PRL 100	133	160	133	160	140	167	148	175	150	177	153	180	159	186
L4 PRL 300	143	170	143	170	150	177	158	185	160	187	163	190	169	196

TRE 200

TR 200

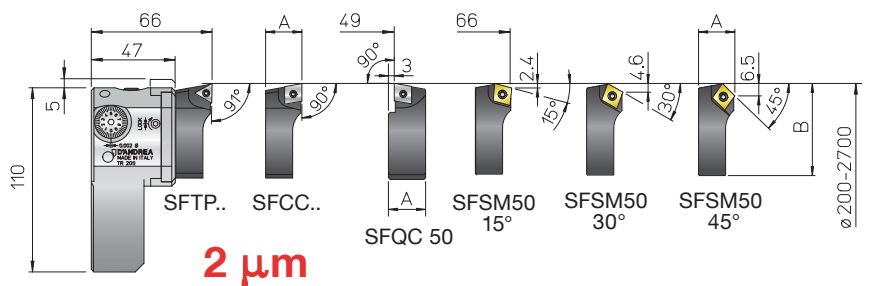
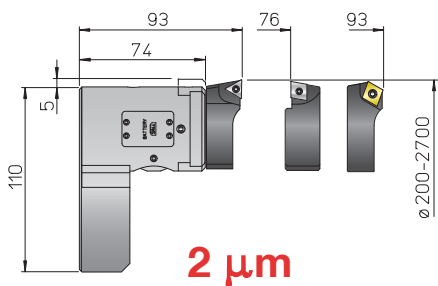

REF.	CODE	Ø	Kg.
TRE 200	455220002001	200 ~ 2700	1.7

REF.	CODE	Ø	Kg.
TR 200	455020002000	200 ~ 2700	1.3

REF.	CODE	A	B	△	□	⊞	⊞	Kg.
SFTP 50	470500550001	19	52	TPGX 1103..		CS 300890T	TORX T08	0.08
SFTP 51	470500550003	21	52	TCMT 16T3..			TS 4 TORX T15	0.09
SFCC 50	470500550002	19	52	CCGT 09T3..			TS 4 TORX T15	0.08
SFCC 51	470500550004	21	52	CCMT 1204..			TS 5 TORX T25	0.09
SFQC 50	470500550062	20.5	53	CCMT 09T3..			TS 4 TORXT15	0.1
SFSM 50-15°	470500550011	19	50.5	CCMT 09T3..			TS 4 TORXT15	0.07
SFSM 50-30°	470500550013	19	50.5	CCMT 09T3..			TS 4 TORXT15	0.07
SFSM 50-45°	470500550015	19	50.5	CCMT 09T3..			TS 4 TORXT15	0.07

## PE ADATTATORI PER PINZE ELASTICHE

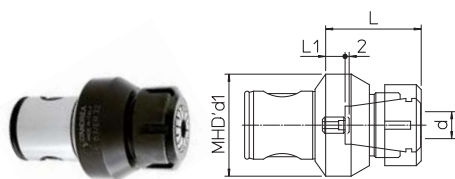

Pinze elastiche e chiavi di serraggio escluse

REF.	CODE	MHD' d1	d	L	L1	kg			N-m
PE 16 / ER11M	655701600110	16	0.5 ~ 7	25	2.5	0.03	ER-11M	E11M	30
PE 20 / ER16M	655702000160	20	0.5 ~ 10	32	1	0.06	ER-16M	E16M	40
PE 25 / ER20M	655702500200	25	1 ~ 13	40	2.5	0.15	ER-20M	E20M	80
PE 32 / ER25M	655703200250	32	1 ~ 16	42	1.5	0.25	ER-25M	E25M	160
PE 40 / ER25	655704000250	40	1 ~ 16	45	5	0.4	UM/ER25	E25	200
PE 50 / ER25	655705000250	50	1 ~ 16	48	7	0.7	UM/ER25	E25	200
PE 50 / ER32	655705000320	50	2 ~ 20	55	8	1	UM/ER32	E32	220
PE 63 / ER32	655706300320	63	2 ~ 20	59	12	1.3	UM/ER32	E32	220
PE 63 / ER40	655706300400	63	3 ~ 26	64	12	1.5	UM/ER40	E40	250

## MHD' FORCE ADATTATORI A FORTE SERRAGGIO

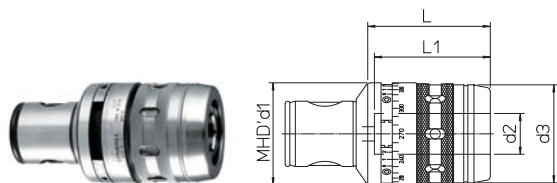

Pinze elastiche e chiavi di serraggio escluse

REF.	CODE	MHD' d1	d2	d3	L	L1	kg
FORCE 50/20 HS	656305000205	50	20	48	60	60	1
FORCE 63/32 HS	656306300325	63	32	66	80	80	2

## AW ADATTATORI WELDON WHISTLE NOTCH

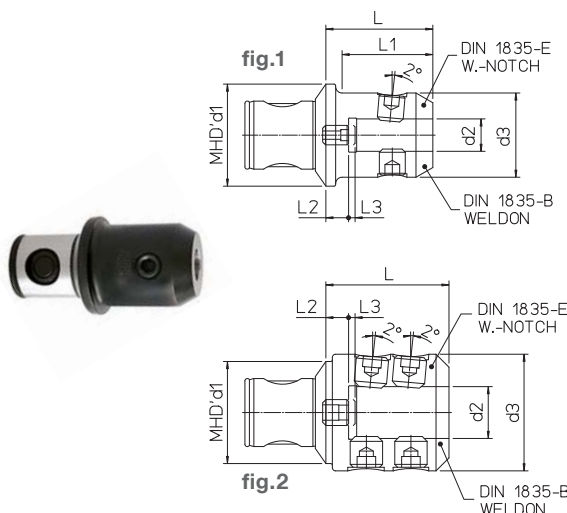

REF.	CODE	MHD' d1	d2 <sup>H5</sup>	d3	L	L1	L2	L3	kg	fig.
AW 50/6	655805000060	50	6	25	44	32.5	7	2	0.5	1
AW 50/8	655805000080	50	8	28	44	33	7	2	0.5	1
AW 50/10	655805000100	50	10	35	52	42	11	3	0.7	1
AW 50/12	655805000120	50	12	42	57	48	11	3	0.8	1
AW 50/14	655805000140	50	14	42	57	48	11	3	0.8	1
AW 50/16	655805000160	50	16	48	67	61	17	4	1.1	1
AW 50/20	655805000200	50	20	51	67		16	4	1.2	1
AW 50/25	655805000250	50	25	63	80		22	4	1.8	2
AW 63/16	655806300160	63	16	48	64	53	14	4	1.4	1
AW 63/20	655806300200	63	20	52	66	56	14	4	1.5	1
AW 63/25	655806300250	63	25	64	74		16	4	2.1	2
AW 63/32	655806300320	63	32	72	76		14	4	2.5	2
AW 80/40	655808000400	80	40	80	83		12	4	3.2	2

## PF ADATTATORI PER FRESE A DISCO E A SPIANARE

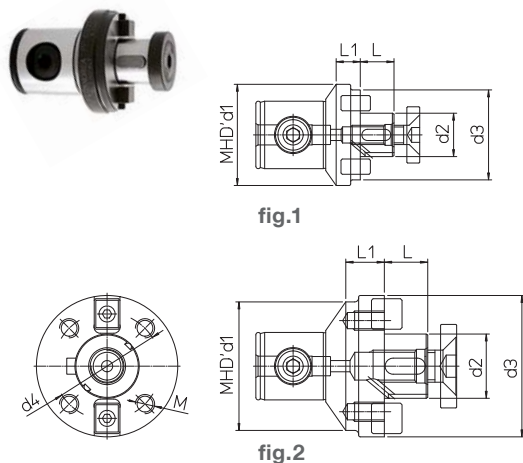

REF.	CODE	MHD' d1	d2	d3	d4	M	L	L1	kg	fig.
PF 40/16	655904020165	40	16	32			17	15	0.3	1
PF 40/22	655904020225	40	22	40			19	13	0.4	1
PF 50/16	655905000160	50	16	32			17	15	0.5	1
PF 50/22	655905000220	50	22	40			19	15	0.5	1
PF 50/27	655905000270	50	27	50			21	15	0.6	1
PF 50/32	655905000320	50	32	60			24	15	0.7	1
PF 63/22	655906300220	63	22	60			19	15	0.9	1
PF 63/27	655906300270	63	27	60			21	15	1.1	1
PF 63/32	655906300320	63	32	63			24	15	1.2	1
PF 80/32	655908000320	80	32	80			24	24	1.7	1
PF 80/40	655908000400	80	40	84	66.7	M12	27	24	1.9	2
PF 80/50	655908000500	80	50	90			30	24	2.0	2
PF 80/60	655908000600	80	60	128.5	101.6	M16	40	31.5	3.5	2
PF 110/40	655911000400	110	40	88	66.7	M12	27	20	4.2	2
PF 110/60	655911000600	110	60	128.5	101.6	M16	40	36	6	2
PF 140/40 •	655914000400	140	40	88	66.7	M12	27	26	6.2	2
PF 140/60 •	655914000600	140	60	140	101.6	M16	40	26	7.8	2

PF.. /40-60 BPS p.57

• Salvo disponibilità magazzino

## B16 ADATTATORI PER MANDRINO B16 D238



REF.	CODE	MHD' d1	L	kg	Adattatori per mandrini portapunte con attacco B16 DIN 238.
B 50/16	656105000160	50	10	0.4	
B 63/16	656106300160	63	13.5	0.8	

## CM ADATTATORI PER CONO MORSE

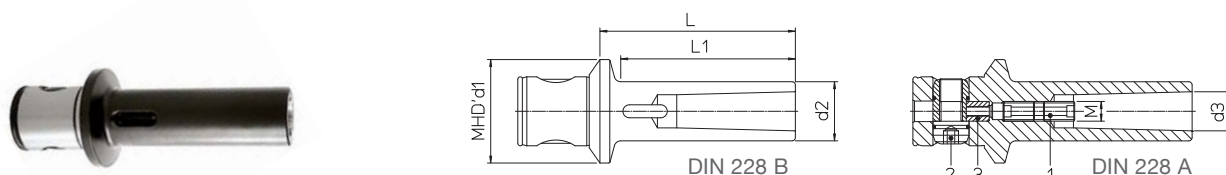

REF.	CODE	MHD' d1	MORSE	d2	d3	L	L1	M	kg
CM 50/1	656005000010	50	1	20	12.065	80	68	M6	0.6
CM 50/2	656005000020	50	2	30	17.780	100	86	M10	0.7
CM 50/3	656005000030	50	3	36	23.825	120	110	M12	1
CM 63/3	656006300030	63	3	36	23.825	120	108	M12	1.3
CM 63/4	656006300040	63	4	48	31.267	150	133	M16	2

**CM DIN 228-A.** Per montare un utensile a cono morse con attacco filettato occorre: a. Montare avvitando interamente la vite 1; b. Togliere il perno espandibile 2 e la bussola 3 per permettere il passaggio posteriore della chiave esagonale; c. Montare l'utensile e avvitare in senso orario la vite 1; d. Rimontare bussola 3 e perno espandibile 2.

**CM DIN 228-B.** Prima di montare un utensile a cono morse con tenone occorre togliere la vite 1. Adattatori combinati per cono morse con foro filettato DIN 228-A e con dente DIN 228-B.

## AM ADATTATORI DI MASCHIATURA CON DOPPIA COMPENSAZIONE

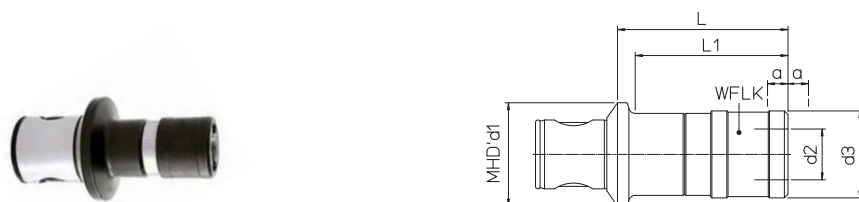

REF.	CODE	MHD' d1	WFLK	Capacity	L	L1	d2	d3	a	kg
AM 50/M3-12	656505000100	50	WFLK 115B/A 308	M 3 ~ 12	72	60	19	36	7.5	0.9
AM 50/M8-20	656505000200	50	WFLK 225B/A 308	M 8 ~ 20	106		31	53	12.5	1.2
AM 63/M3-12	656506300100	63	WFLK 115B/A 308	M 3 ~ 12	70	58	19	36	7.5	1
AM 63/M8-20	656506300200	63	WFLK 225B/A 308	M 8 ~ 20	104	93	31	53	12.5	1.3

## NS ADATTATORI SEMILAVORATI

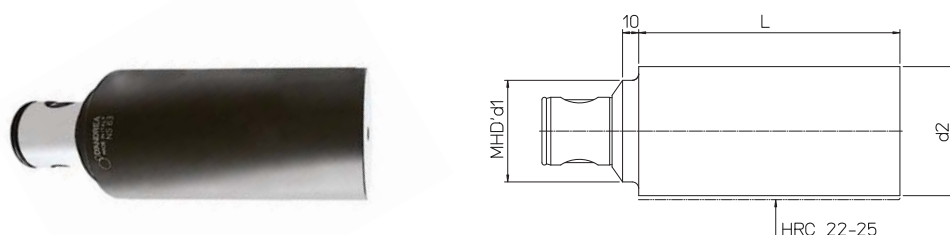

REF.	CODE	MHD' d1	d2	L	kg	SPECIALI A RICHIESTA
NS 50	657205001600	50	63	160	4.2	
NS 63	657206302000	63	80	200	8.7	
NS 80	657208002500	80	100	250	16	
NS 110	657211002500	110	130	250	18	
NS 140	657214002500	140	150	250	30	



## WCGT ○○○○○○L

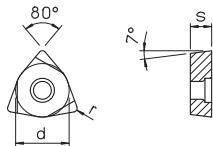

REF.	d	s	r	T	S	METALLO DURO		CERMET	CERMET RIVESTITO
						DP300	DK100	DC100	DC100T
WCGT 020102 L	3.97	1.59	0.2	TS 21*-TS 211*	TORX T06	•	•	•	•
WCGT 020104 L	3.97	1.59	0.4	TS 21*-TS 211*	TORX T06	•	•	•	•

\* TS21 : B...06 / \* TS211 : B...08

## CCGT ○○○○○○L

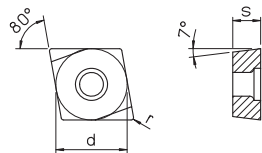

REF.	d	s	r	T	S	METALLO DURO		CERMET	CERMET RIVESTITO
						DP300	DK100	DC100	DC100T
CCGT 060200 L10°	6.35	2.38	0	TS 25	TORX T08	•	•	•	•
CCGT 060202 L	6.35	2.38	0.2	TS 25	TORX T08	•	•	•	•
CCGT 060204 L	6.35	2.38	0.4	TS 25	TORX T08	•	•	•	•
CCGT 09T302 L	9.525	3.97	0.2	TS 4	TORX T15	•	•	•	•
CCGT 09T304 L	9.525	3.97	0.4	TS 4	TORX T15	•	•	•	•

## TPGX ○○○○○○L

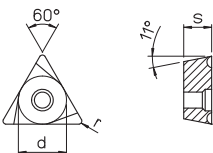

REF.	d	s	r	T	S	METALLO DURO		CERMET	CERMET RIVESTITO
						DP300	DK100	DC100	DC100T
TPGX 090200 L10°	5.56	2.38	0	CS250T	TORX T08	•	•	•	•
TPGX 090202 L	5.56	2.38	0.2	CS250T	TORX T08	•	•	•	•
TPGX 090204 L	5.56	2.38	0.4	CS250T	TORX T08	•	•	•	•
TPGX 110300 L10°	6.35	3.18	0	CS300890T	TORX T08	•	•	•	•
TPGX 110302 L	6.35	3.18	0.2	CS300890T	TORX T08	•	•	•	•
TPGX 110304 L	6.35	3.18	0.4	CS300890T	TORX T08	•	•	•	•

## TPGX ○○○○○○

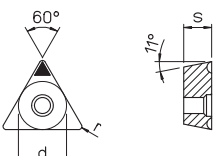

REF.	d	s	r	T	S	DIAMANTE POLICRISTALLINO		NITRURO CUBICO DI BORO	
						D20 MDC	D20 CBN	D25 CBN	D25 CBN
TPGX 090202	5.56	2.38	0.2	CS250T	TORX T08	•	•	•	•
TPGX 090204	5.56	2.38	0.4	CS250T	TORX T08	•	•	•	•
TPGX 110302	6.35	3.18	0.2	CS300890T	TORX T08	•	•	•	•
TPGX 110304	6.35	3.18	0.4	CS300890T	TORX T08	•	•	•	•

## CCMT ○○○○○○

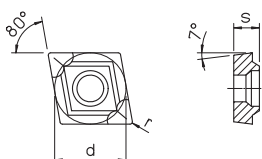

REF.	d	s	r	T	S	METALLO DURO	
						DP300	DP100 R
CCMT 060202	6.35	2.38	0.2	TS 25	TORX T08	•	•
CCMT 060204	6.35	2.38	0.4	TS 25	TORX T08	•	•
CCMT 09T304	9.525	3.97	0.4	TS 4	TORX T15	•	•
CCMT 09T308	9.525	3.97	0.8	TS 4	TORX T15	•	•
CCMT 120404	12.7	4.76	0.4	TS 5	TORX T25	•	•
CCMT 120408	12.7	4.76	0.8	TS 5	TORX T25	•	•

# QUALITÀ DI BARENATURA

ISO	METALLO DURO	CERMET	CERMET RIVESTITO	METALLO DURO RIVESTITO CVD
P01				
P10		DC100	DC100T	DP100R
P20				
P30	DP300			
P40				
K01				
K10	DK100	DC100	DC100T	DP100R
K20	DP300			
K30				

<b>DP300</b>	Sgrossatura e finitura. Acciai a basso tenore di carbonio - acciai inox
<b>DK100</b>	Sgrossatura e finitura. Leghe di alluminio Ghise
<b>DP100R</b>	Sgrossatura. Acciai, acciai legati e ghise
<b>DC100</b>	Finitura. Acciai legati in genere e ghise sferoidali
<b>DC100T</b>	Finitura. Acciai legati in genere, acciai inox e ghise sferoidali
<b>D20MDC</b>	Finitura. Leghe di alluminio, materiali non-ferrosi e non-metalli
<b>D20CBN</b>	Finitura. Acciai con elevata durezza superiore 50 HRC (può sostituire la rettifica)
<b>D25CBN</b>	Finitura. Acciai con elevata durezza superiore 50 HRC e taglio interrotto (può sostituire la rettifica)

TORX

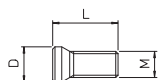

REF.		CODE	M	L	D	Nm	REF.		CODE
TS 21		494010002034	M 2x0.4	3.7	2.7	0,5	TORX T06		10 150 09 0 0600
TS 211		494010002040	M 2x0.4	4	2.7	0,5	TORX T06		10 150 09 0 0600
CS 250 T		494010002565	M 2.5x0.45	6	3.7	1,0	TORX T08		10 150 09 0 0800
CS 300890 T		494010003008	M 3x0.5	8	4.1	1,0	TORX T08		10 150 09 0 0800
TS 25		494010002555	M 2.5x0.45	5.7	3.45	1,0	TORX T08		10 150 09 0 0800
TS 4		494010004008	M 4x0.7	10	5.5	3,0	TORX T15		10 150 09 0 1500
TS 5		494010005009	M 5x0.8	11.5	7	7,5	TORX T25		10 150 09 0 2500



# PSC Linea

È una linea di portautensili modulari di alta precisione che consente di eseguire con estrema flessibilità e rigidità operazioni di alesatura, fresatura e foratura.



## ATTACCHI BASE

**DIN-AD / PSC**  
DIN 69871 / ISO 26623-2



**MAS BT / PSC**  
MAS 403 BT / ISO 26623-2



**HSK-A / PSC**  
DIN 69893 / ISO 26623-2



**CAT-AD+B / PSC**  
ANSI B5.50 / ISO 26623-2



## PROLUNGHE RIDUZIONI

**PR / PSC**  
ISO 26623-1 / 2



**RD / PSC**  
ISO 26623-1 / 2



## RIDUZIONI A MODULARE

**PSC - MHD<sup>1</sup>**  
ISO 26623-1



## PORTAFRESE

**PSC-PF**  
ISO 26623-1



## FORTE SERRAGGIO

**PSC-MF**  
ISO 26623-1



## ADATTATORI SEMILAVORATI

**PSC NS-H.28-42**  
ISO 26623-1



## A RICHIESTA TRE PSC - TR PSC



**TRE 50 PSC50 69K**  
Ø 2.5-110

**TRE 63 PSC63 69K**  
Ø 6 ~ 125

**TRE 80 PSC80 69K**  
Ø 6 ~ 200



**TR 50 PSC 40**  
**TR 50 PSC 50**  
**TR 50 PSC 63**  
Ø 2.5 ~ 108

**TR 63 PSC 63**  
Ø 2.5 ~ 125

**TR 80 PSC 80**  
Ø 2.5 ~ 160

## A RICHIESTA ALTRI ATTACCHI

L'attacco PSC è conforme alla normativa ISO 26623 ed è disponibile in sei grandezze. Garantisce l'intercambiabilità di tutti gli elementi del sistema, che include attacchi base, prolunghes, riduzioni e adattatori portautensili.

## Attacco PSC ISO 26623-1/2

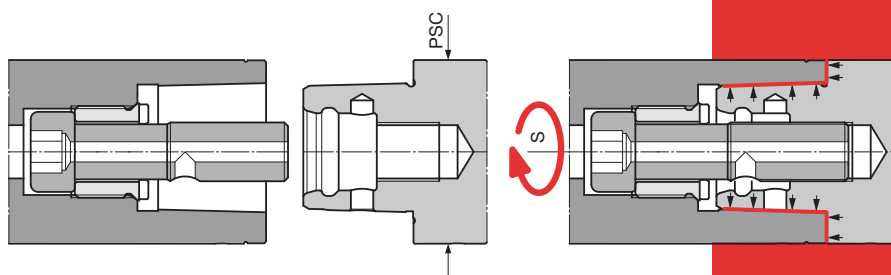

Il programma si integra con la **linea di alesatura MHD'** che completa la linea PSC con un'ampia gamma di testine di sgrossatura e di finitura, queste ultime sia analogiche che digitali.

PSC	S	⬡ Nm
PSC 32	8	45
PSC 40	8	55
PSC 50	10	95
PSC 63	14	170
PSC 80	14	170
PSC 100	17	380

**ATTACCHI BASE** realizzati secondo normative DIN 69871, MAS 403 BT, ANSI-CAT, DIN 69893 e costruiti in acciaio cementato, temprato e rettificato.

**PR e RD** Per ogni grandezza PSC esistono prolunghes e riduzioni di diverse lunghezze che consentono di raggiungere le profondità di lavorazione desiderate.

**RD MHD'** Le riduzioni MHD' permettono di integrare al programma PSC Linea la linea di alesatura MHD'.

**PF** Adattatori portafresa che, fra l'altro permettono l'impiego della linea BPS per grandi diametri.

**MONOforce** Linea di portautensili a forte serraggio ideale per lavorazioni ove sussistano esigenze di precisione e necessità di serraggio utensili sollecitati ad elevati carichi torsionali.



## DIN-AD / PSC DIN 69871 / ISO 26623-2

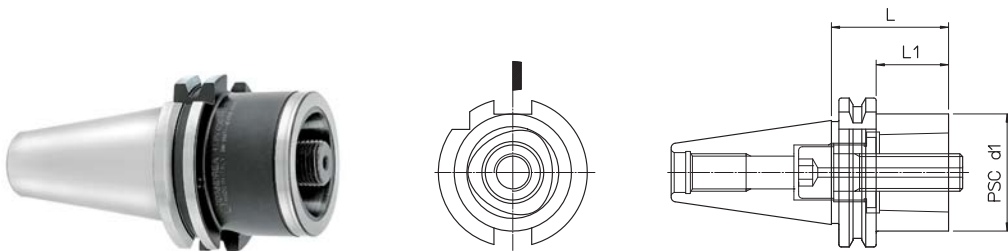

DIN	REF.	CODE	PSC d1	L	L1	kg
40	DIN69871-AD40 PSC 40.30	41PS04014020	40	30	11	0.8
40	DIN69871-AD40 PSC 50.40	41PS05014028	50	40	21	0.9
40	DIN69871-AD40 PSC 50.50	41PS05014022	50	50	31	1.1
50	DIN69871-AD50 PSC 50.30	41PS05015020	50	30	11	2.7
50	DIN69871-AD50 PSC 63.30	41PS06315028	63	30	11	2.8
50	DIN69871-AD50 PSC 63.50	41PS06315022	63	50	31	3
50	DIN69871-AD50 PSC 80.70	41PS08015020	80	70	51	3.7

## HSK-A / PSC DIN 69893 / ISO 26623-2

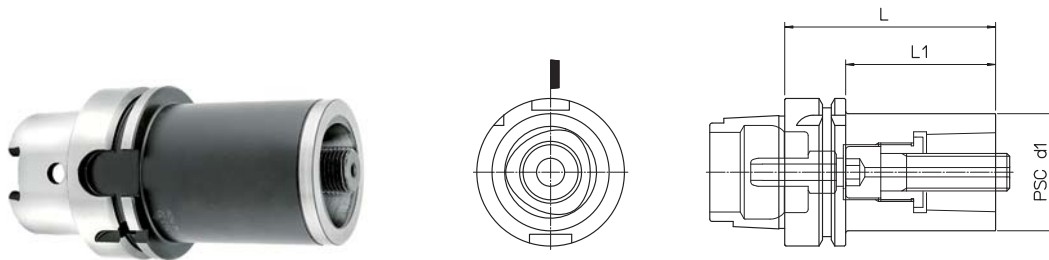

Completo di raccordo per il refrigerante

HSK-A	REF.	CODE	PSC d1	L	L1	kg
63	HSK-A63 PSC 40.80	41PS04056320	40	80	54	1.1
63	HSK-A63 PSC 50.90	41PS05056320	50	90	64	1.5
100	HSK-A100 PSC 50.100	41PS05059920	50	100	71	3
100	HSK-A100 PSC 63.110	41PS06359920	63	110	81	3.6
100	HSK-A100 PSC 80.120	41PS08059920	80	120	91	4.7
125	HSK-A125 PSC 80.130	41PS08059520	80	130	101	6.5

## MAS BT-AD / PSC MAS 403 BT / ISO 26623-2

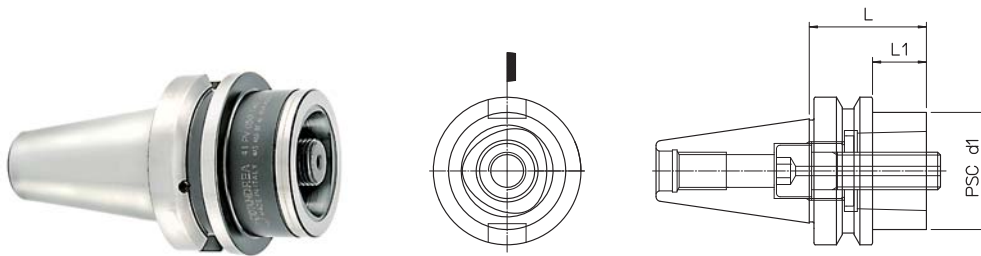

BT	REF.	CODE	PSC d1	L	L1	kg
40	MAS403 BT40-AD PSC 40.30	41PS04014030	40	30	3	0.9
40	MAS403 BT40-AD PSC 50.50	41PS05014032	50	50	23	1.2
50	MAS403 BT50-AD PSC 50.40	41PS05015030	50	40	2	3.4
50	MAS403 BT50-AD PSC 63.50	41PS06315032	63	50	12	3.5
50	MAS403 BT50-AD PSC 80.70	41PS08015030	80	70	32	4

## CAT-AD / PSC ANSI B5.50 / ISO 26623-2

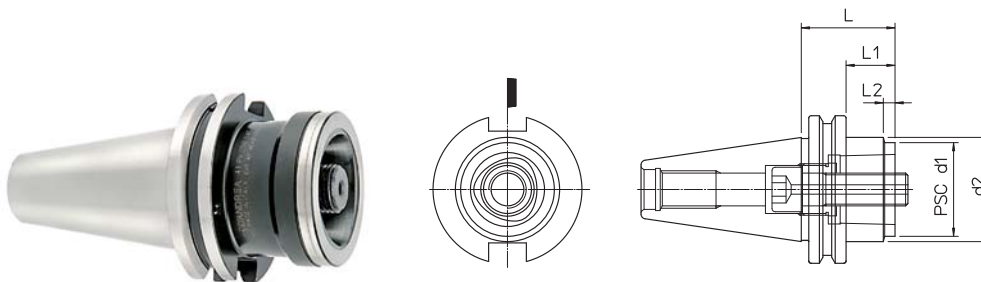

CAT	REF.	CODE	PSC d1	d2	L	L1	L2	M	kg
40	CAT40 AD PSC 40.40	41PS04014045	40	44.5	40	21	5	UNC 5/8-11	0.95
40	CAT40 AD PSC 50.50	41PS05014045	50		50	31		UNC 5/8-11	1
50	CAT50 AD PSC 50.40	41PS05015045	50	69.9	40	21	5	UNC 1/8	2.5
50	CAT50 AD PSC 63.50	41PS06315045	63	70	50	31	12.5	UNC 1/8	3
50	CAT50 AD PSC 80.100	41PS08015045	80		100	81		UNC 1/8	4.6

### RD PSC ISO 26623-1 / 2

#### PROLUNGHE

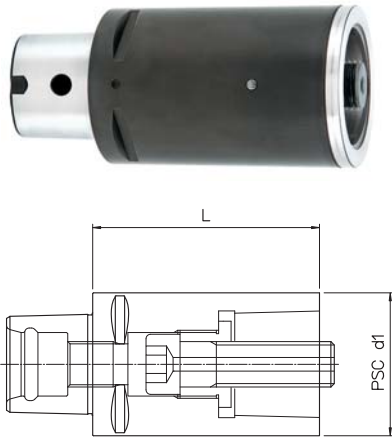

REF.	CODE	PSC d1	L	kg
PR PSC 32.60	656PS03206000	32	60	0.35
PR PSC 32.80	656PS03208000	32	80	0.45
PR PSC 40.60	656PS04006000	40	60	0.55
PR PSC 40.80	656PS04008000	40	80	0.7
PR PSC 40.100	656PS04010000	40	100	0.9
PR PSC 50.80	656PS05008000	50	80	1.1
PR PSC 50.100	656PS05010000	50	100	1.4
PR PSC 63.100	656PS06310000	63	100	2.2
PR PSC 63.140	656PS06314000	63	140	3.2
PR PSC 80.100	656PS08010000	80	100	3.6
PR PSC 80.125	656PS08012500	80	125	4.5

### RD PSC ISO 26623-1 / 2

#### RIDUZIONI

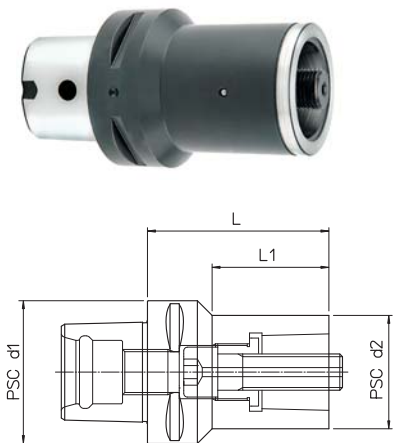

REF.	CODE	PSC d1	PSC d2	L	L1	kg
RD PSC 40/32.70	657PS04003200	40	32	70	12	0.6
RD PSC 50/32.60	657PS05003200	50	32	60	34.8	0.65
RD PSC 50/40.65	657PS05004000	50	40	65	45	0.7
RD PSC 50/40.85	657PS05004001	50	40	85	12	1
RD PSC 63/32.70	657PS06303200	63	32	70	39	1.1
RD PSC 63/40.80	657PS06304000	63	40	80	51.4	1.3
RD PSC 63/50.80	657PS06305000	63	50	80	51.5	1.5
RD PSC 63/50.110	657PS06305001	63	50	110	12	3.4
RD PSC 80/32.60	657PS08003200	80	32	60	29.3	1.8
RD PSC 80/40.70	657PS08004000	80	40	70	36.5	1.9
RD PSC 80/50.80	657PS08005000	80	50	80	49.3	2.2
RD PSC 80/63.80	657PS08006300	80	63	80	53.1	2.5
RD PSC 80/63.120	657PS08006301	80	63	120	12	3.9
RD PSC 100/80.100	657PS10008000	100	80	100	58.2	5

### PSC-MHD' ISO 26623-1

#### RIDUZIONI A MODULARE

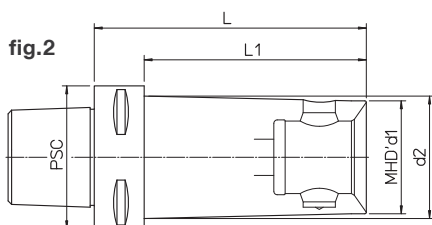
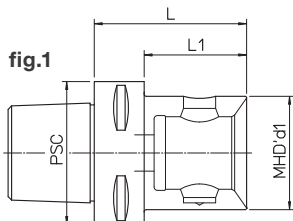

PSC	REF.	CODE	MHD' d1	d2	L	L1	Kg.	fig.
40	PSC 40 - MHD' 32.42	416322604004	32	-	42	22	0.3	1
40	PSC 40 - MHD' 40.45	416402604004	40	-	45	-	0.4	1
50	PSC 50 - MHD' 50.55	416502605005	50	-	55	-	0.8	1
63	PSC 63 - MHD' 40.50	416402606305	40	-	50	28	0.9	1
63	PSC 63 - MHD' 40.120	416402606312	40	44	120	98	1.5	2
63	PSC 63 - MHD' 50.55	416502606305	50	-	55	33	0.8	1
63	PSC 63 - MHD' 50.67	416502606306	50	-	67	45	1.1	1
63	PSC 63 - MHD' 50.120	416502606312	50	54	120	98	1.9	2
63	PSC 63 - MHD' 63.77	416632606307	63	-	77	-	1.8	1
80	PSC 80 - MHD' 50.60	416502608006	50	-	60	30	2	1
80	PSC 80 - MHD' 50.120	416502608012	50	54	120	90	2.8	2
80	PSC 80 - MHD' 63.70	416632608007	63	-	70	40	2.3	1
80	PSC 80 - MHD' 63.150	416632608015	63	67	150	120	4	2
80	PSC 80 - MHD' 80.75	416802608007	80	-	75	-	2.6	1
80	PSC 80 - MHD' 80.120	416802608012	80	-	120	-	4.3	1
100	PSC 100 - MHD' 80.80	416802610008	110	-	80	44	3.5	1
100	PSC 100 - MHD' 110.120	416912610012	110	-	120	84	5	1



# PORTAFRESE - FORTE SERRAGGIO - SEMILAVORATI

**PSC-PF** ISO 26623-1

PORTAFRESE

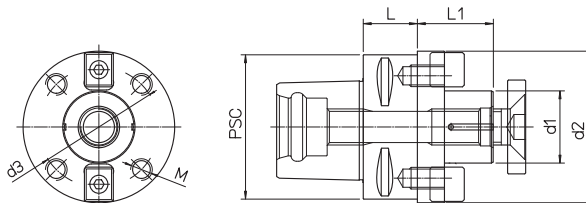

• Salvo disponibilità magazzino

PSC	REF.	CODE	d1	d2	d3	M	L	L1	kg
40	<b>PSC 40 PF22.25</b>	71PSC-040PF2202 •	22				25	19	0.3
50	<b>PSC 50 PF22.25</b>	71PSC-050PF2202	22				25	19	0.5
50	<b>PSC 50 PF27.25</b>	71PSC-050PF2702 •	27				25	21	0.6
63	<b>PSC 63 PF27.25</b>	71PSC-063PF2702	27				25	21	0.8
63	<b>PSC 63 PF32.25</b>	71PSC-063PF3202 •	32				25	24	0.9
80	<b>PSC 80 PF32.30</b>	71PSC-080PF3203 •	32				30	24	1.8
80	<b>PSC 80 PF40.45</b>	71PSC-080PF4004 •	40	84	66.7	M12	45	27	2.4
80	<b>PSC 80 PF60.60</b>	71PSC-080PF6006 •	60	128.5	101.6	M16	60	40	5.2

PSC 80  
PF 40 - 60 BPS p.57

**ISO 26623-1 PSC**

FORTE SERRAGGIO

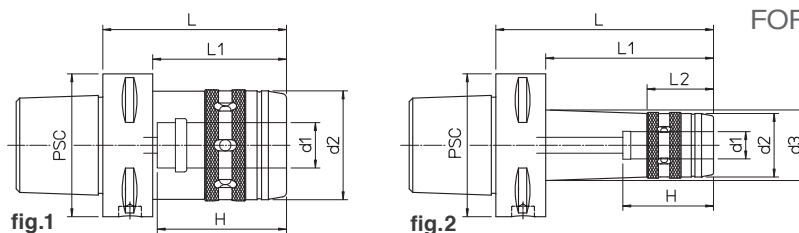

Chiave di serraggio esclusa - Predisposizione Chip

PSC	REF.	CODE	d1	d2	d3	H	L	L1	L2	kg	fig.
63	<b>PSC 63 - MF 12.70</b>	71PSC-063MF1207	12	28		46	70	48		0.9	1
63	<b>PSC 63 - MF 12.100</b>	71PSC-063MF1210	12	28	31.5	46	100	78	29.5	1.4	2
63	<b>PSC 63 - MF 20.80</b>	71PSC-063MF2008	20	48		60	80	58		1.3	1
63	<b>PSC 63 - MF 20.120</b>	71PSC-063MF2012	20	48		60	120	98		1.9	2
63	<b>PSC 63 - MF 32.100</b>	71PSC-063MF3210	32	66		80	100			2.1	1
63	<b>PSC 63 - MF 32.140</b>	71PSC-063MF3214	32	66		80	140			3.1	2
80	<b>PSC 80 - MF 20.80</b>	71PSC-080MF2008	20	48		60	80	50		3.7	1
80	<b>PSC 80 - MF 20.125</b>	71PSC-080MF2012	20	48		60	125	95		4.1	2
80	<b>PSC 80 - MF 32.100</b>	71PSC-080MF3210	32	66		80	100	70		4.4	1
80	<b>PSC 80 - MF 32.160</b>	71PSC-080MF3216	32	66		80	160	130		4.9	2

**PSC NS-H.28-42** ISO 26623-1

ADATTATORI SEMILAVORATI

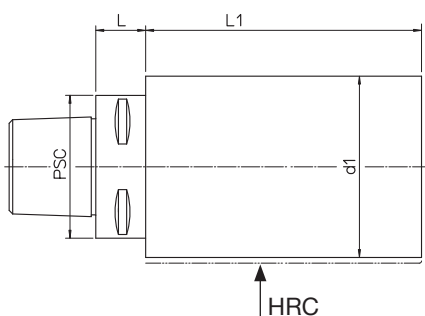

PSC	REF.	CODE	d1	L	L1	kg	HRC
40	<b>PSC 40 - NS 50.160/140 H.28</b>	71PSC040Z205014	50	20	140	2.4	28
40	<b>PSC 40 - NS 50.160/140 H.42</b>	71PSC040Z405014	50	20	140	2.4	42
40	<b>PSC 40 - NS 63.160/140 H.28</b>	71PSC040Z206314	63	20	140	3.6	28
40	<b>PSC 40 - NS 63.160/140 H.42</b>	71PSC040Z406314	63	20	140	3.6	42
40	<b>PSC 40 - NS 80.160/140 H.28</b>	71PSC040Z208014	80	20	140	5.7	28
40	<b>PSC 40 - NS 80.160/140 H.42</b>	71PSC040Z408014	80	20	140	5.7	42
50	<b>PSC 50 - NS 63.160/140 H.28</b>	71PSC050Z206314	63	20	140	3.8	28
50	<b>PSC 50 - NS 63.160/140 H.42</b>	71PSC050Z406314	63	20	140	3.8	42
50	<b>PSC 50 - NS 80.160/140 H.28</b>	71PSC050Z208014	80	20	140	10.2	28
50	<b>PSC 50 - NS 80.160/140 H.42</b>	71PSC050Z408014	80	20	140	10.2	42
50	<b>PSC 50 - NS 100.180/160 H.28</b>	71PSC050Z210016	100	20	160	5.9	28
50	<b>PSC 50 - NS 100.180/160 H.42</b>	71PSC050Z410016	100	22	160	5.9	42
63	<b>PSC 63 - NS 80.162/140 H.28</b>	71PSC063Z208014	80	22	140	6.2	28
63	<b>PSC 63 - NS 80.162/140 H.42</b>	71PSC063Z408014	80	22	140	6.2	42
63	<b>PSC 63 - NS 100.182/160 H.28</b>	71PSC063Z210016	100	22	160	10.4	28
63	<b>PSC 63 - NS 100.182/160 H.42</b>	71PSC063Z410016	100	22	160	10.4	42
63	<b>PSC 63 - NS 120.202/180 H.28</b>	71PSC063Z212018	120	22	180	17	28
63	<b>PSC 63 - NS 120.202/180 H.42</b>	71PSC063Z412018	120	22	180	17	42
80	<b>PSC 80 - NS 100.190/160 H.28</b>	71PSC080Z210016	100	30	160	11.5	28
80	<b>PSC 80 - NS 100.190/160 H.42</b>	71PSC080Z410016	100	30	160	11.5	42
80	<b>PSC 80 - NS 140.210/180 H.28</b>	71PSC080Z214018	140	30	180	23.4	28
80	<b>PSC 80 - NS 140.210/180 H.42</b>	71PSC080Z414018	140	30	180	23.4	42

# MONOforce

**MONOforce** rappresenta la soluzione ideale ed economica per l'attrezzatura di tutte le macchine utensili in particolare ove sussistano esigenze di precisione e necessità di serraggio utensili sollecitati a elevati carichi torsionali.



Costruito nella versione per mandrini macchina HSK 63 e 100, ISO 26623-1 PSC 63 e 80, nonché DIN 69871 e MAS-BT 40 e 50, permette l'impiego di bussole di riduzione da Ø 12 mm, Ø 20 mm e Ø 32 mm, disponibili in tutta la gamma diametrale compatibile con questi diametri d'alloggiamento per serraggi da Ø 3 mm a Ø 25 mm, anche a TENUTA.



**DIN 69871 AD**

**MAS 403 BT AD**

**DIN 69893 HSK**

**ISO 26623-1 PSC**

MAX.	RPM 15.000
------	------------

MAX.	40 BAR
------	--------

# PORTAUTENSILI A FORTE SERRAGGIO

## DIN 69871 AD

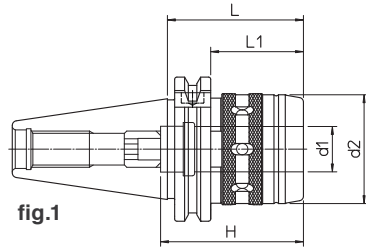

fig.1

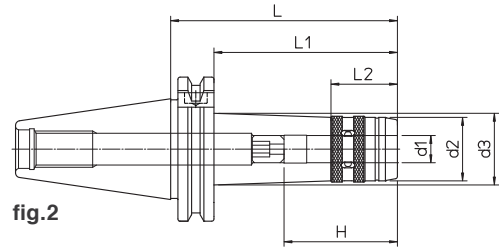

fig.2

Chiave di serraggio esclusa - Predisposizione Chip

DIN	REF.	CODE	d1	d2	d3	H	L	L1	L2	kg	fig.
40	DIN69871-AD40 MF12.50	71DIN-A40MF1205	12	28		46	50	31		0.8	1
40	DIN69871-AD40 MF12.100	71DIN-A40MF1210	12	28	32	46	100	81	29.5	1.2	2
40	DIN69871-AD40 MF20.60	71DIN-A40MF2006	20	48		63	60	41		1.1	1
40	DIN69871-AD40 MF20.100	71DIN-A40MF2010	20	48		63	100	81		1.4	2
40	DIN69871-AD40 MF32.95	71DIN-A40MF3209	32	66		80	95			1.6	1
40	DIN69871-AD40 MF32.140	71DIN-A40MF3214	32	66		80	140			2.0	2
50	DIN69871-AD50 MF20.80	71DIN-A50MF2008	20	48		63	80	61		2.3	1
50	DIN69871-AD50 MF20.125	71DIN-A50MF2012	20	48		63	125	106		2.7	2
50	DIN69871-AD50 MF32.75	71DIN-A50MF3207	32	66		90	75	56		2.8	1
50	DIN69871-AD50 MF32.160	71DIN-A50MF3216	32	66		90	160	141		3.2	2

## MAS 403 BT AD

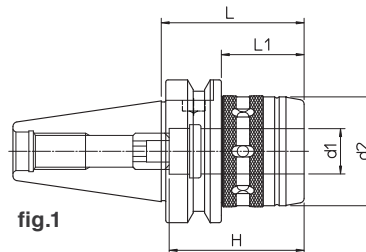

fig.1

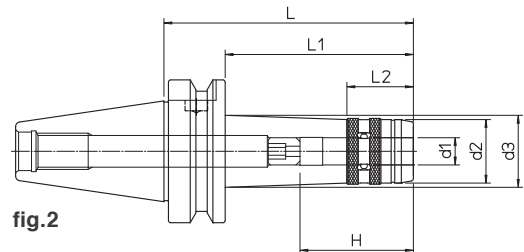

fig.2

Chiave di serraggio esclusa - Predisposizione Chip

BT	REF.	CODE	d1	d2	d3	H	L	L1	L2	kg	fig.
40	MAS403 BT40-AD MF12.60	71MBT-A40MF1206	12	28		46	60	33		0.9	1
40	MAS403 BT40-AD MF12.100	71MBT-A40MF1210	12	28	32	46	100	73	29.5	1.4	2
40	MAS403 BT40-AD MF20.65	71MBT-A40MF2007	20	48		63	65	38		1.3	1
40	MAS403 BT40-AD MF20.100	71MBT-A40MF2010	20	48		63	100	73		1.9	2
40	MAS403 BT40-AD MF32.90	71MBT-A40MF3209	32	66		80	90			2.1	1
40	MAS403 BT40-AD MF32.140	71MBT-A40MF3214	32	66		80	140			3.1	2
50	MAS403 BT50-AD MF20.85	71MBT-A50MF2008	20	48		63	85	47		3.7	1
50	MAS403 BT50-AD MF20.125	71MBT-A50MF2012	20	48		63	125	87		4.1	2
50	MAS403 BT50-AD MF32.95	71MBT-A50MF3209	32	66		90	95	57		4.4	1
50	MAS403 BT50-AD MF32.160	71MBT-A50MF3216	32	66		90	160	122		4.9	2

## MAS 403 BT AD FACE CONTACT

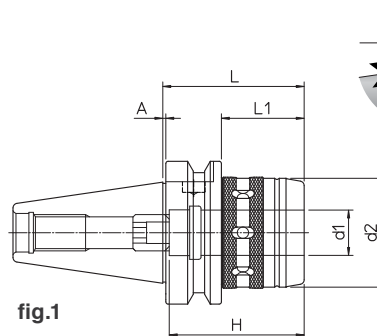

fig.1

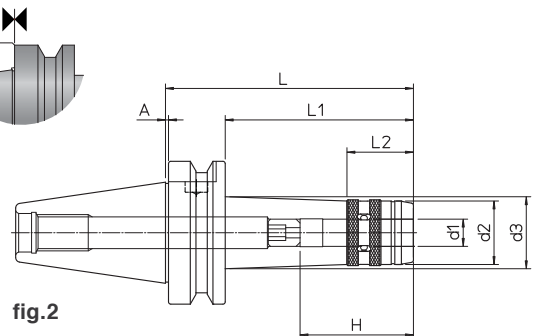
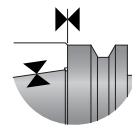

fig.2

Chiave di serraggio esclusa - Predisposizione Chip

BT	REF.	CODE	d1	d2	d3	H	A	L	L1	L2	kg	fig.
40	MAS403 BT40-AD FC MF12.100	71MBF-A40MF1210	12	28	32	46	1	100	73	29.5	1.4	2
40	MAS403 BT40-AD FC MF20.65	71MBF-A40MF2007	20	48		63	1	65	38		1.3	1
40	MAS403 BT40-AD FC MF32.90	71MBF-A40MF3209	32	66		80	1	90			2.1	1
50	MAS403 BT50-AD FC MF20.85	71MBF-A50MF2008	20	48		63	1.5	85	47		3.7	1
50	MAS403 BT50-AD FC MF32.95	71MBF-A50MF3209	32	66		90	1.5	95	57		4.4	1

### DIN 69893 HSK-A

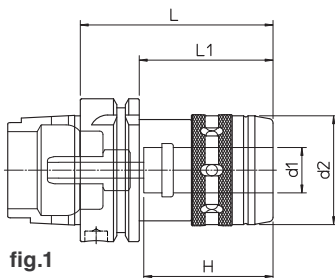

fig.1

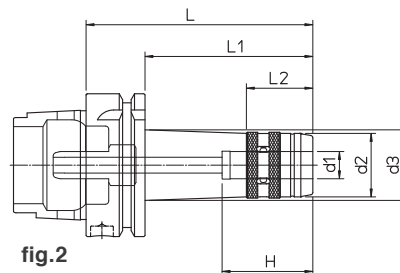

fig.2

Completo di raccordo per il refrigerante - Chiave di serraggio esclusa - Predisposizione Chip

HSK-A	REF.	CODE	d1	d2	d3	H	L	L1	L2	kg	fig.
63	HSK-A63 MF12.70	71HSK-A63MF1207	12	28		46	70	44		0.8	1
63	HSK-A63 MF12.100	71HSK-A63MF1210	12	28	32	46	100	74	29.5	1.1	2
63	HSK-A63 MF20.85	71HSK-A63MF2008	20	48		60	85	59		1.2	1
63	HSK-A63 MF20.125	71HSK-A63MF2012	20	48		60	125	99		1.7	2
63	HSK-A63 MF32.105	71HSK-A63MF3210	32	66		80	105			2	1
63	HSK-A63 MF32.140	71HSK-A63MF3214	32	66		80	140			2.6	2
100	HSK-A100 MF20.95	71HSKA100MF2009	20	48		60	95	66		2.8	1
100	HSK-A100 MF32.110	71HSKA100MF3211	32	66		80	110	81		3.1	1
100	HSK-A100 MF32.160	71HSKA100MF3216	32	66		80	160	131		3.6	1
125	HSK-A125 MF32.120	71HSKA125MF3212	32	66		80	120	91		5.3	1

### ISO 26623-1 PSC

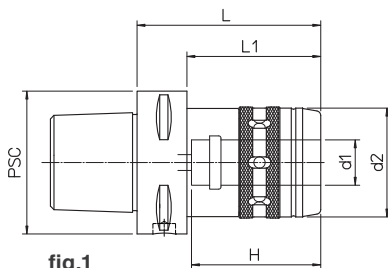

fig.1

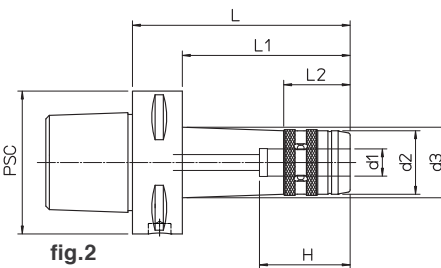

fig.2

Chiave di serraggio esclusa - Predisposizione Chip

PSC	REF.	CODE	d1	d2	d3	H	L	L1	L2	kg	fig.
63	PSC 63 - MF 12.70	71PSC-063MF1207	12	28		46	70	48		0.9	1
63	PSC 63 - MF 12.100	71PSC-063MF1210	12	28	31.5	46	100	78	29.5	1.4	2
63	PSC 63 - MF 20.80	71PSC-063MF2008	20	48		60	80	58		1.3	1
63	PSC 63 - MF 20.120	71PSC-063MF2012	20	48		60	120	98		1.9	2
63	PSC 63 - MF 32.100	71PSC-063MF3210	32	66		80	100			2.1	1
63	PSC 63 - MF 32.140	71PSC-063MF3214	32	66		80	140			3.1	2
80	PSC 80 - MF 20.80	71PSC-080MF2008	20	48		60	80	50		3.7	1
80	PSC 80 - MF 20.125	71PSC-080MF2012	20	48		60	125	95		4.1	2
80	PSC 80 - MF 32.100	71PSC-080MF3210	32	66		80	100	70		4.4	1
80	PSC 80 - MF 32.160	71PSC-080MF3216	32	66		80	160	130		4.9	2

#### KIT K01

MONOforce 12



1 RC 12.04  
1 RC 12.06  
1 RC 12.08  
1 RC 12.10  
1 CHV 28

#### KIT K01

MONOforce 20



1 RC 20.06  
1 RC 20.08  
1 RC 20.10  
1 RC 20.12  
1 RC 20.16  
1 CHV 50

#### KIT K01

MONOforce 32



1 RC 32.06  
1 RC 32.08  
1 RC 32.10  
1 RC 32.12  
1 RC 32.16  
1 RC 32.20  
1 RC 32.25  
1 CHV 75

A RICHIESTA KIT K01 FACE CONTACT

DIN	REF.	CODE	Kg.
40	KIT K01 MONOFORCE 12.50 DIN40AD	7KDIN-A40MF1205	1.5
40	KIT K01 MONOFORCE 20.60 DIN40AD	7KDIN-A40MF2006	2
40	KIT K01 MONOFORCE 32.95 DIN40AD	7KDIN-A40MF3209	4.4
50	KIT K01 MONOFORCE 20.80 DIN50AD	7KDIN-A50MF2008	4.6
50	KIT K01 MONOFORCE 32.75 DIN50AD	7KDIN-A50MF3207	6.2

BT	REF.	CODE	Kg.
40	KIT K01 MONOFORCE 12.60 BT40AD	7KMBT-A40MF1206	1.5
40	KIT K01 MONOFORCE 20.65 BT40AD	7KMBT-A40MF2007	2.3
40	KIT K01 MONOFORCE 32.90 BT40AD	7KMBT-A40MF3209	4.6
50	KIT K01 MONOFORCE 20.85 BT50AD	7KMBT-A50MF2008	5.4
50	KIT K01 MONOFORCE 32.95 BT50AD	7KMBT-A50MF3209	7.5

HSK-A	REF.	CODE	Kg.
63	KIT K01 MONOFORCE 12.70 HSK63	7KHSA-A63MF1207	1.5
63	KIT K01 MONOFORCE 20.85 HSK63	7KHSA-A63MF2008	2.3
63	KIT K01 MONOFORCE 32.105 HSK63	7KHSA-A63MF3210	4.5
100	KIT K01 MONOFORCE 32.110 HSK100	7KHSA100MF3211	6.7

# PROLUNGHE CALETTAMENTO TERMICO

## PR CT N PROLUNGHE A CALETTAMENTO TERMICO

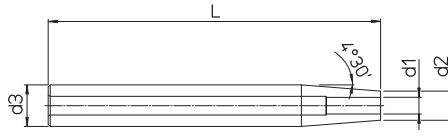

REF.	CODE	d1	d2	d3	L	kg
PR.CT.N D12.03.160	49DC11612030	3	8	12	160	0.09
PR.CT.N D12.04.160	49DC11612040	4	8	12	160	0.09
PR.CT.N D16.03.160	49DC11616030	3	10	16	160	0.14
PR.CT.N D16.04.160	49DC11616040	4	10	16	160	0.14
PR.CT.N D16.05.160	49DC11616050	5	10	16	160	0.15
PR.CT.N D16.06.160	49DC11616060	6	12	16	160	0.16
PR.CT.N D16.08.160	49DC11616080	8	14	16	160	0.16
PR.CT.N D20.05.160	49DC11620050	5	14	20	160	0.27
PR.CT.N D20.06.160	49DC11620060	6	14	20	160	0.26
PR.CT.N D20.08.160	49DC11620080	8	14	20	160	0.26
PR.CT.N D20.10.160	49DC11620100	10	16	20	160	0.21
PR.CT.N D20.12.160	49DC11620120	12	18	20	160	0.22

## PR CT R PROLUNGHE A CALETTAMENTO TERMICO A REGOLAZIONE ASSIALE

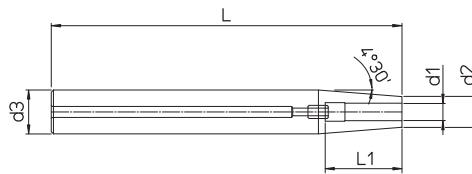

Completo di grano regolazione assiale

REF.	CODE	d1	d2	d3	L	L1	kg
PR.CT.R D16.06.130	49DC21316060	6	10	16	130	22 / 36	0.18
PR.CT.R D16.06.160	49DC21616060	6	10	16	160	22 / 36	0.17
PR.CT.R D20.06.130	49DC21320060	6	14	20	130	22 / 36	0.20
PR.CT.R D20.08.130	49DC21320080	8	14	20	130	22 / 36	0.25
PR.CT.R D20.06.160	49DC21620060	6	14	20	160	22 / 32	0.33
PR.CT.R D20.08.160	49DC21620080	8	14	20	160	26 / 36	0.32
PR.CT.R D25.10.130	49DC21325100	10	20	25	130	31 / 41	0.40
PR.CT.R D25.12.130	49DC21325120	12	20	25	130	36 / 46	0.37
PR.CT.R D25.16.130	49DC21325160	16	22	25	130	39 / 49	0.32
PR.CT.R D25.08.160	49DC21625080	8	19	25	160	26 / 36	0.53
PR.CT.R D25.10.160	49DC21625100	10	20	25	160	31 / 41	0.51
PR.CT.R D25.12.160	49DC21625120	12	20	25	160	36 / 46	0.48
PR.CT.R D25.14.160	49DC21625140	14	22	25	160	36 / 46	0.47
PR.CT.R D25.16.160	49DC21625160	16	22	25	160	39 / 49	0.43
PR.CT.R D25.08.200	49DC22025080	8	19	25	200	26 / 36	0.67
PR.CT.R D25.10.200	49DC22025100	10	20	25	200	31 / 41	0.64
PR.CT.R D25.12.200	49DC22025120	12	20	25	200	36 / 46	0.60
PR.CT.R D25.16.200	49DC22025160	16	22	25	200	39 / 49	0.52
PR.CT.R D32.16.160	49DC21632160	16	27	32	160	39 / 49	0.78
PR.CT.R D32.18.160	49DC21632180	18	27	32	160	39 / 49	0.77
PR.CT.R D32.20.160	49DC21632200	20	27	32	160	41 / 51	0.67
PR.CT.R D32.16.200	49DC22032160	16	27	32	200	39 / 49	1.81
PR.CT.R D32.20.200	49DC22032200	20	27	32	200	41 / 51	0.87



# MONOd'

I portautensili integrali **MONOd'** rappresentano la soluzione ideale per attrezzare ogni tipo di macchina utensile con attacco base HSK 63 e 100, DIN 69871 e MAS-BT 40 e 50, garantendo i vantaggi di elevata qualità e alto grado di precisione, con un prezzo di mercato altamente concorrenziale.



Il programma MONOd' include portapinze ER, Weldon, Portafrese, Riduzioni Morse e Maschiatori.

Tutti i portautensili sono equilibrati di progetto, G 6,3 a 8.000 giri/min. MONOd' ER G 6,3 a 15.000 giri/min.



 0.003

MAX. RPM 15.000

**DIN 69893 HSK**

**DIN 69871**

**MAS 403 BT**

## DIN 69893 HSK-A PORTAPINZE - ER DIN 6499

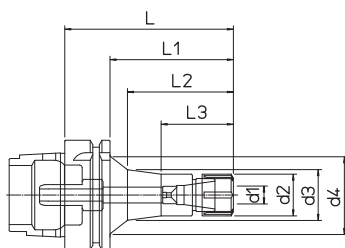

Pinze elastiche e chiavi di serraggio escluse

Completo di raccordo per il refrigerante

HSK-A	REF.	CODE	TYPE	d1	d2	d3	d4	L	L1	L2	L3	kg
63	HSK-A63 ER16.80	71HSKA063ER1608	ER 16 M	0.5 ~ 10	22	32		80	54	41		1.1
63	HSK-A63 ER16.120	71HSKA063ER1612	ER 16 M	0.5 ~ 10	22	31		120	94			1.9
63	HSK-A63 ER25.80	71HSKA063ER2508	ER 25	1 ~ 16	42			80	54			1.3
63	HSK-A63 ER25.140	71HSKA063ER2514	ER 25	1 ~ 16	42	47.5		140	114	46		1.7
63	HSK-A63 ER32.90	71HSKA063ER3209	ER 32	2 ~ 20	50			90	64			1.6
63	HSK-A63 ER32.160	71HSKA063ER3216	ER 32	2 ~ 20	50			160	134			2.2
100	HSK-A100 ER16.100	71HSKA100ER1610	ER 16 M	0.5 ~ 10	22	25	45	100	71	61	41.5	2.3
100	HSK-A100 ER16.160	71HSKA100ER1616	ER 16 M	0.5 ~ 10	22	34.5	44	160	131	126		2.5
100	HSK-A100 ER25.100	71HSKA100ER2510	ER 25	1 ~ 16	42	45.5		100	71	47		2.6
100	HSK-A100 ER25.160	71HSKA100ER2516	ER 25	1 ~ 16	42	49.5		160	131	47		3.2
100	HSK-A100 ER32.120	71HSKA100ER3212	ER 32	2 ~ 20	50	55		120	91	52		3.1
100	HSK-A100 ER32.160	71HSKA100ER3216	ER 32	2 ~ 20	50	56.5		160	131	52		3.7
100	HSK-A100 ER40.120	71HSKA100ER4012	ER 40	3 ~ 26	63	71.5		120	91	60		3.5

## DIN 69893 HSK-A WELDON - WD DIN 1835-B

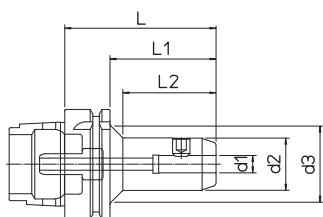

Completo di raccordo per il refrigerante

HSK-A	REF.	CODE	d1 <sup>H5</sup>	d2	d3	L	L1	L2	kg
63	HSK-A63 WD06.60	71HSKA063WD0606	6	23		60	34		0.8
63	HSK-A63 WD08.65	71HSKA063WD0806	8	26		65	39		0.9
63	HSK-A63 WD10.70	71HSKA063WD1007	10	30		70	44		1.1
63	HSK-A63 WD12.70	71HSKA063WD1207	12	34		70	44		1.2
63	HSK-A63 WD16.80	71HSKA063WD1608	16	42		80	54		1.4
63	HSK-A63 WD20.80	71HSKA063WD2008	20	50		80	54		1.5
63	HSK-A63 WD25.110	71HSKA063WD2511	25	63		110			2.3
63	HSK-A63 WD32.110	71HSKA063WD3211	32	70		110			2.5
100	HSK-A100 WD10.90	71HSKA100WD1009	10	30	45	90	61	53.5	2.3
100	HSK-A100 WD12.100	71HSKA100WD1210	12	34	45	100	71	65.5	2.4
100	HSK-A100 WD16.100	71HSKA100WD1610	16	42		100	71		2.6
100	HSK-A100 WD20.110	71HSKA100WD2011	20	50		110	81		3.1
100	HSK-A100 WD25.120	71HSKA100WD2512	25	63		120	91		3.9
100	HSK-A100 WD32.120	71HSKA100WD3212	32	70		120	91		4.3
100	HSK-A100 WD40.120	71HSKA100WD4012	40	80		120	91		4.8

## DIN 69893 HSK-A PORTAFRESE - PF

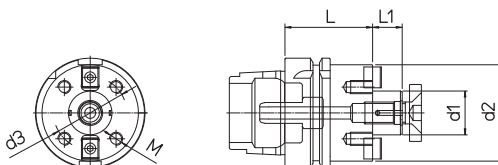

Completo di raccordo per il refrigerante

HSK-A	REF.	CODE	d1	d2	d3	M	L	L1	kg
63	HSK-A63 PF16.50	71HSKA063PF1605	16	32			50	17	1.1
63	HSK-A63 PF22.50	71HSKA063PF2205	22	40			50	19	1.2
63	HSK-A63 PF27.55	71HSKA063PF2705	27	50			55	21	1.4
63	HSK-A63 PF32.60	71HSKA063PF3206	32	60			60	24	1.8
100	HSK-A100 PF22.65	71HSKA100PF2265	22	40			65	19	2.3
100	HSK-A100 PF27.65	71HSKA100PF2765	27	50			65	21	2.5
100	HSK-A100 PF32.70	71HSKA100PF3270	32	60			70	24	2.9
100	HSK-A100 PF40.70	71HSKA100PF4070	40	88	66.7	M12	70	27	3.3
100	HSK-A100 PF60.75	71HSKA100PF6075	60	128.5	101.6	M16	75	40	4.2

## DIN 69893 HSK-A MORSE - CM DIN 228 AB

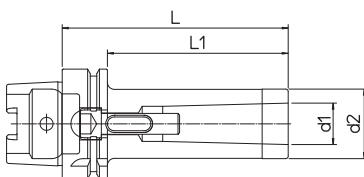

HSK-A	REF.	CODE	MORSE	d1	d2	L	L1	kg
63	HSK-A63 CM2.110 A-B	71HSKA063CMB211	2	17.780	32	110	84	2
63	HSK-A63 CM3.130 A-B	71HSKA063CMB313	3	23.825	40	130	104	2.2
63	HSK-A63 CM4.155 A-B	71HSKA063CMB415	4	31.267	48	155	129	2.6

## DIN 69871 AD PORTAPINZE - ER DIN 6499

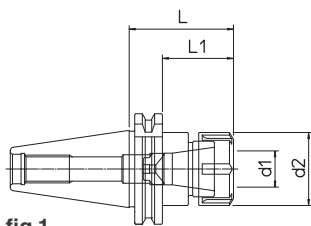

fig.1

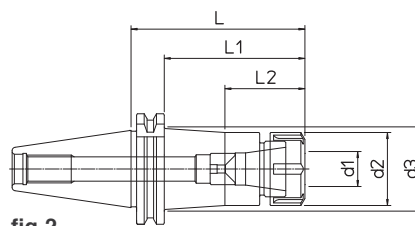

fig.2

Pinze elastiche e chiavi di serraggio escluse

DIN	REF.	CODE	TYPE	d1	d2	d3	L	L1	L2	kg	fig.
40	DIN69871-AD40 ER16.60	71DIN-A40ER1606	ER 16 M	0.5 ~ 10	22		60	41		0.9	1
40	DIN69871-AD40 ER16.100	71DIN-A40ER1610	ER 16 M	0.5 ~ 10	22	29.5	100	81	41	1	2
40	DIN69871-AD40 ER16.160	71DIN-A40ER1616	ER 16 M	0.5 ~ 10	22	38	160	141	41	2	2
40	DIN69871-AD40 ER25.60	71DIN-A40ER2506	ER 25	1 ~ 16	42		60	41		1.1	1
40	DIN69871-AD40 ER25.100	71DIN-A40ER2510	ER 25	1 ~ 16	42	47	100	81	46	1.6	2
40	DIN69871-AD40 ER25.160	71DIN-A40ER2516	ER 25	1 ~ 16	42	50	160	141	46	2.1	2
40	DIN69871-AD40 ER32.70	71DIN-A40ER3207	ER 32	2 ~ 20	50		70	51		1.2	1
40	DIN69871-AD40 ER32.110	71DIN-A40ER3211	ER 32	2 ~ 20	50		110	91		1.7	1
40	DIN69871-AD40 ER32.160	71DIN-A40ER3216	ER 32	2 ~ 20	50		160	141		2.7	1
40	DIN69871-AD40 ER40.80	71DIN-A40ER4008	ER 40	3 ~ 26	63		80	61		1.3	1
40	DIN69871-AD40 ER40.120	71DIN-A40ER4012	ER 40	3 ~ 26	63		120	101		2.3	1
50	DIN69871-AD50 ER16.100	71DIN-A50ER1610	ER 16 M	0.5 ~ 10	22	29.5	100	81	41	2.5	2
50	DIN69871-AD50 ER16.160	71DIN-A50ER1616	ER 16 M	0.5 ~ 10	22	32.5	160	141	41	3.3	2
50	DIN69871-AD50 ER25.110	71DIN-A50ER2511	ER 25	1 ~ 16	42	48	110	91	46	2.8	2
50	DIN69871-AD50 ER25.160	71DIN-A50ER2516	ER 25	1 ~ 16	42	50	160	141	46	3.6	2
50	DIN69871-AD50 ER32.70	71DIN-A50ER3207	ER 32	2 ~ 20	50		70	51		2.9	1
50	DIN69871-AD50 ER32.110	71DIN-A50ER3211	ER 32	2 ~ 20	50	55	110	91	52	3.4	2
50	DIN69871-AD50 ER32.160	71DIN-A50ER3216	ER 32	2 ~ 20	50	57.5	160	141	52	4	2
50	DIN69871-AD50 ER40.100	71DIN-A50ER4010	ER 40	3 ~ 26	63	65	100	81	55	3.8	2
50	DIN69871-AD50 ER40.160	71DIN-A50ER4016	ER 40	3 ~ 26	63	70	160	141	55	4.3	2

## DIN 69871 AD PORTAFRESE - PF

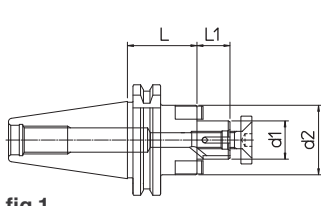

fig.1

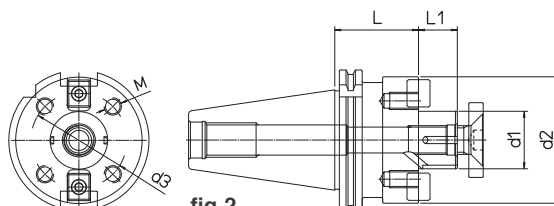

fig.2

DIN	REF.	CODE	d1	d2	d3	M	L	L1	kg	fig.
40	DIN69871-AD40 PF16.35	71DIN-A40PF1603	16	32			35	17	0.9	1
40	DIN69871-AD40 PF22.40	71DIN-A40PF2204	22	40			40	19	1	1
40	DIN69871-AD40 PF27.45	71DIN-A40PF2704	27	50			45	21	1.2	1
40	DIN69871-AD40 PF32.50	71DIN-A40PF3205	32	60			50	24	1.7	1
40	DIN69871-AD40 PF40.55	71DIN-A40PF4005	40	70			55	27	2.1	1
50	DIN69871-AD50 PF16.40	71DIN-A50PF1604	16	32			40	17	2.4	1
50	DIN69871-AD50 PF16.110	71DIN-A50PF1611	16	32			110	17	2.8	1
50	DIN69871-AD50 PF22.45	71DIN-A50PF2204	22	40			45	19	2.6	1
50	DIN69871-AD50 PF27.50	71DIN-A50PF2705	27	50			50	21	2.7	1
50	DIN69871-AD50 PF32.55	71DIN-A50PF3205	32	60			55	24	3.2	1
50	DIN69871-AD50 PF40.60	71DIN-A50PF4006	40	88	66.7	M12	60	27	4.3	2
50	DIN69871-AD50 PF60.70	71DIN-A50PF6007	60	128.5	101.6	M16	70	40	6.6	2

PF.. /40-60 BPS p.57

## DIN 69871 AD WELDON - WD DIN 1835-B

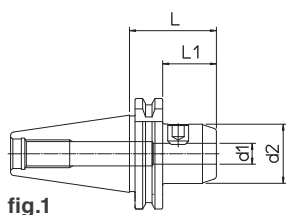

fig.1

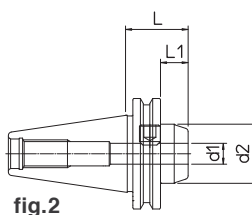

fig.2

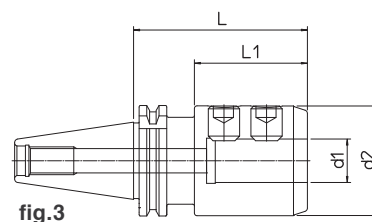
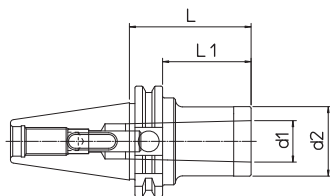

fig.3

DIN	REF.	CODICE	d1 <sup>H5</sup>	d2	L	L1	kg	fig.
40	DIN69871-AD40 WD06.50	71DIN-A40WD0605	6	23	50	31	0.8	1
40	DIN69871-AD40 WD08.50	71DIN-A40WD0805	8	26	50	31	0.9	1
40	DIN69871-AD40 WD10.50	71DIN-A40WD1005	10	30	50	31	1	1
40	DIN69871-AD40 WD12.35	71DIN-A40WD1203	12	34	35	16	1	2
40	DIN69871-AD40 WD12.110	71DIN-A40WD1211	12	34	110	91	1.4	1
40	DIN69871-AD40 WD16.35	71DIN-A40WD1603	16	42	35	16	1.1	2
40	DIN69871-AD40 WD16.110	71DIN-A40WD1611	16	42	110	91	1.7	1
40	DIN69871-AD40 WD16.160	71DIN-A40WD1616	16	42	160	141	2.2	1
40	DIN69871-AD40 WD20.35	71DIN-A40WD2003	20	44	35	16	1.2	2
40	DIN69871-AD40 WD20.110	71DIN-A40WD2011	20	50	110	91	2.1	1
40	DIN69871-AD40 WD20.160	71DIN-A40WD2016	20	50	160	141	2.6	1
40	DIN69871-AD40 WD25.35	71DIN-A40WD2503	25	44	35	16	1.3	2
40	DIN69871-AD40 WD25.100	71DIN-A40WD2510	25	63	100	65	2	3
40	DIN69871-AD40 WD25.160	71DIN-A40WD2516	25	63	160	125	3.2	3
40	DIN69871-AD40 WD32.100	71DIN-A40WD3210	32	70	100	65	2.5	3
40	DIN69871-AD40 WD32.160	71DIN-A40WD3216	32	70	160	125	3.9	3
50	DIN69871-AD50 WD10.63	71DIN-A50WD1006	10	30	63	44	2.5	1
50	DIN69871-AD50 WD10.160	71DIN-A50WD1016	10	30	160	141	2.9	1
50	DIN69871-AD50 WD12.63	71DIN-A50WD1206	12	34	63	44	2.6	1
50	DIN69871-AD50 WD12.160	71DIN-A50WD1216	12	34	160	141	3.2	1
50	DIN69871-AD50 WD16.110	71DIN-A50WD1611	16	42	110	91	3.2	1
50	DIN69871-AD50 WD16.160	71DIN-A50WD1616	16	42	160	141	3.7	1
50	DIN69871-AD50 WD20.110	71DIN-A50WD2011	20	50	110	91	3.6	1
50	DIN69871-AD50 WD20.160	71DIN-A50WD2016	20	50	160	141	4.2	1
50	DIN69871-AD50 WD25.80	71DIN-A50WD2508	25	63	80	61	3.5	1
50	DIN69871-AD50 WD25.110	71DIN-A50WD2511	25	63	110	91	4.1	2
50	DIN69871-AD50 WD25.160	71DIN-A50WD2516	25	63	160	141	5.1	2
50	DIN69871-AD50 WD32.100	71DIN-A50WD3210	32	70	100	81	4.6	2
50	DIN69871-AD50 WD32.160	71DIN-A50WD3216	32	70	160	141	6	2
50	DIN69871-AD50 WD40.100	71DIN-A50WD4010	40	80	100	81	4.8	2

## DIN 69871 A MORSE - CM DIN 228 AB



DIN	REF.	-CODE	MORSE	d1	d2	L	L1	kg
40	DIN69871-A40 CM2.50 A-B	71DIN-40-CMB205	2	17.780	32	50	31	1
40	DIN69871-A40 CM3.70 A-B	71DIN-40-CMB307	3	23.825	40	70	51	1.1
50	DIN69871-A50 CM2.60 A-B	71DIN-50-CMB206	2	17.780	32	60	41	2.6
50	DIN69871-A50 CM3.60 A-B	71DIN-50-CMB306	3	23.825	40	60	41	2.7
50	DIN69871-A50 CM4.80 A-B	71DIN-50-CMB408	4	31.267	48	80	61	2.9

## MAS 403 BT40 AD PORTAPINZE - ER DIN 6499

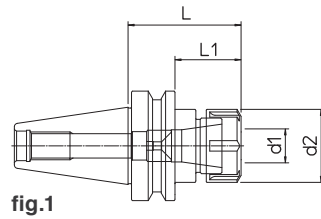

fig.1

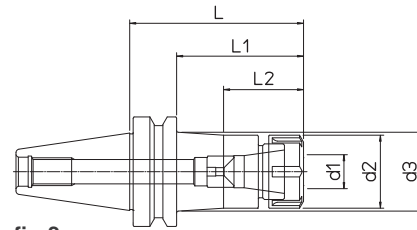

fig.2

Pinze elastiche e chiavi di serraggio escluse

BT	REF.	CODE	TYPE	d1	d2	d3	L	L1	L2	kg	fig.
40	MAS403 BT40-AD ER16.60	71MBT-A40ER1606	ER 16 M	0.5 ~ 10	22		60	33		1	1
40	MAS403 BT40-AD ER16.100	71MBT-A40ER1610	ER 16 M	0.5 ~ 10	22	28	100	73	41	1.1	2
40	MAS403 BT40-AD ER16.160	71MBT-A40ER1616	ER 16 M	0.5 ~ 10	22	36.5	160	133	41	2.1	2
40	MAS403 BT40-AD ER25.65	71MBT-A40ER2506	ER 25	1 ~ 16	42		65	38		1.2	1
40	MAS403 BT40-AD ER25.100	71MBT-A40ER2510	ER 25	1 ~ 16	42	45.5	100	73	46	1.7	2
40	MAS403 BT40-AD ER25.160	71MBT-A40ER2516	ER 25	1 ~ 16	42	49.5	160	133	46	2.2	2
40	MAS403 BT40-AD ER32.70	71MBT-A40ER3207	ER 32	2 ~ 20	50		70	43		1.3	1
40	MAS403 BT40-AD ER32.110	71MBT-A40ER3211	ER 32	2 ~ 20	50		110	83		1.8	1
40	MAS403 BT40-AD ER32.160	71MBT-A40ER3216	ER 32	2 ~ 20	50		160	133		2.8	1
40	MAS403 BT40-AD ER40.80	71MBT-A40ER4008	ER 40	3 ~ 26	63		80	53		1.4	1
40	MAS403 BT40-AD ER40.120	71MBT-A40ER4012	ER 40	3 ~ 26	63		120	93		2.4	1
50	MAS403 BT50-AD ER16.100	71MBT-A50ER1610	ER 16 M	0.5 ~ 10	22	26.5	100	62	41	3.6	2
50	MAS403 BT50-AD ER16.160	71MBT-A50ER1616	ER 16 M	0.5 ~ 10	22	31	160	122	41	4.3	2
50	MAS403 BT50-AD ER25.110	71MBT-A50ER2511	ER 25	1 ~ 16	42	45.5	110	72	46	3.8	2
50	MAS403 BT50-AD ER25.160	71MBT-A50ER2516	ER 25	1 ~ 16	42	48.5	160	122	46	4.6	2
50	MAS403 BT50-AD ER32.80	71MBT-A50ER3208	ER 32	2 ~ 20	50		80	42		3.9	1
50	MAS403 BT50-AD ER32.110	71MBT-A50ER3211	ER 32	2 ~ 20	50	52.5	110	72	52	4.4	2
50	MAS403 BT50-AD ER32.160	71MBT-A50ER3216	ER 32	2 ~ 20	50	56	160	122	52	5	2
50	MAS403 BT50-AD ER40.100	71MBT-A50ER4010	ER 40	3 ~ 26	63		100	62		4.8	1
50	MAS403 BT50-AD ER40.160	71MBT-A50ER4016	ER 40	3 ~ 26	63	68.5	160	122	55	5.3	2

## MAS 403 BT40 AD PORTAFRESE - PF

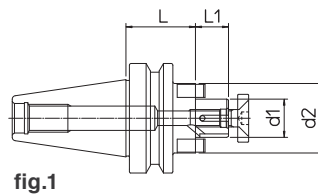

fig.1

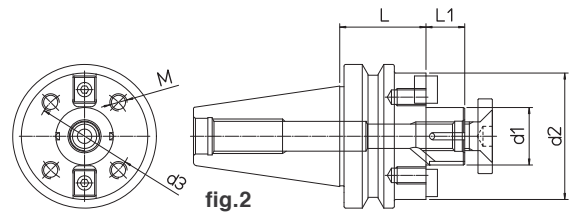

fig.2

BT	REF.	CODE	d1	d2	d3	M	L	L1	kg	fig.
40	MAS403 BT40-AD PF16.40	71MBT-A40PF1604	16	32			40	17	0.9	1
40	MAS403 BT40-AD PF22.40	71MBT-A40PF2204	22	40			40	19	1	1
40	MAS403 BT40-AD PF27.45	71MBT-A40PF2704	27	50			45	21	1.2	1
40	MAS403 BT40-AD PF32.50	71MBT-A40PF3205	32	60			50	24	1.7	1
40	MAS403 BT40-AD PF40.55	71MBT-A40PF4005	40	70			55	27	2.1	1
50	MAS403 BT50-AD PF16.50	71MBT-A50PF1605	16	32			50	17	2.4	1
50	MAS403 BT50-AD PF22.50	71MBT-A50PF2205	22	40			50	19	2.6	1
50	MAS403 BT50-AD PF27.55	71MBT-A50PF2705	27	50			55	21	2.7	1
50	MAS403 BT50-AD PF32.55	71MBT-A50PF3205	32	60			55	24	3.2	1
50	MAS403 BT50-AD PF40.60	71MBT-A50PF4006	40	88	66.7	M12	60	27	4.3	2
50	MAS403 BT50-AD PF60.80	71MBT-A50PF6008	60	128.5	101.6	M16	80	40	6.8	2

PF.. /40-60 BPS p.57



## MAS 403 BT40 AD WELDON - WD DIN 1835-B

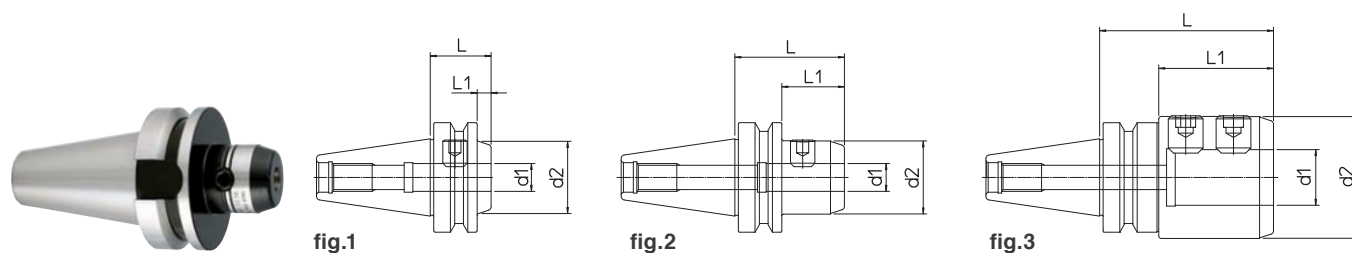

BT	REF.	CODE	d1 <sup>H5</sup>	d2	L	L1	kg	fig.
40	MAS403 BT40-AD WD06.50	71MBT-A40WD0605	6	23	50	23	0.8	1
40	MAS403 BT40-AD WD08.50	71MBT-A40WD0805	8	26	50	23	0.9	1
40	MAS403 BT40-AD WD10.56	71MBT-A40WD1005	10	30	56	29	1	1
40	MAS403 BT40-AD WD12.35	71MBT-A40WD1203	12	34	35	8	0.9	2
40	MAS403 BT40-AD WD12.110	71MBT-A40WD1211	12	34	110	83	1.4	1
40	MAS403 BT40-AD WD16.35	71MBT-A40WD1603	16	42	35	8	1	2
40	MAS403 BT40-AD WD16.110	71MBT-A40WD1611	16	42	110	83	1.7	1
40	MAS403 BT40-AD WD20.35	71MBT-A40WD2003	20	50	35	8	1.1	2
40	MAS403 BT40-AD WD20.110	71MBT-A40WD2011	20	50	110	83	2.1	1
40	MAS403 BT40-AD WD25.35	71MBT-A40WD2503	25	63	35	8	1	2
40	MAS403 BT40-AD WD25.100	71MBT-A40WD2510	25	63	100	73	2	3
40	MAS403 BT40-AD WD32.100	71MBT-A40WD3210	32	70	100	67	2.5	3
50	MAS403 BT50-AD WD10.70	71MBT-A50WD1007	10	30	70	32	3	1
50	MAS403 BT50-AD WD10.160	71MBT-A50WD1016	10	30	160	122	3.4	1
50	MAS403 BT50-AD WD12.70	71MBT-A50WD1207	12	34	70	32	3.1	1
50	MAS403 BT50-AD WD12.160	71MBT-A50WD1216	12	34	160	122	3.6	1
50	MAS403 BT50-AD WD16.80	71MBT-A50WD1608	16	42	80	42	3.3	1
50	MAS403 BT50-AD WD16.110	71MBT-A50WD1611	16	42	110	72	3.5	1
50	MAS403 BT50-AD WD20.80	71MBT-A50WD2008	20	50	80	42	3.5	1
50	MAS403 BT50-AD WD20.110	71MBT-A50WD2011	20	50	110	72	3.8	1
50	MAS403 BT50-AD WD25.100	71MBT-A50WD2510	25	63	100	62	4.5	2
50	MAS403 BT50-AD WD25.125	71MBT-A50WD2512	25	63	125	87	5	2
50	MAS403 BT50-AD WD32.100	71MBT-A50WD3210	32	70	100	62	5.6	2
50	MAS403 BT50-AD WD40.110	71MBT-A50WD4011	40	80	110	72	5.8	2

## MAS 403 BT40 A MORSE - CM DIN 228 AB

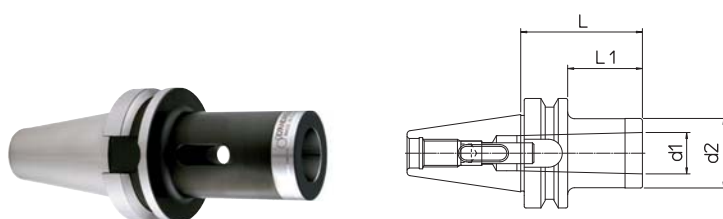

BT	REF.	CODE	MORSE	d1	d2	L	L1	kg
40	MAS403 BT40-A CM2.50 A-B	71MBT-40-CMB205	2	17.780	32	50	23	1
40	MAS403 BT40-A CM3.70 A-B	71MBT-40-CMB307	3	23.825	40	70	43	1.1
50	MAS403 BT50-A CM2.60 A-B	71MBT-50-CMB206	2	17.780	32	60	22	2.6
50	MAS403 BT50-A CM3.60 A-B	71MBT-50-CMB306	3	23.825	40	60	22	2.7
50	MAS403 BT50-A CM4.80 A-B	71MBT-50-CMB408	4	31.267	48	80	42	2.9



**ISO 7388/2 A - DIN 69872**

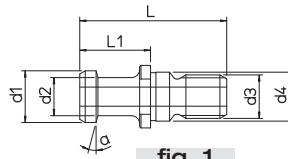

fig. 1

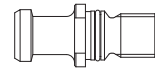

fig. 2

REF.	CODE	ISO	d1	d2	d3	d4	L	L1	a	fig.
ISO 7388/2 A DIN 69872	201430250401	40	19	14	M16	17	54	26	15°	1
ISO 7388/2 A DIN 69872	201430250451	45	23	17	M20	21	65	30	15°	1
ISO 7388/2 A DIN 69872	201430250501	50	28	21	M24	25	74	34	15°	1
ISO 7388/2 A DIN 69872	201430250400	40	19	14	M16	17	54	26	15°	2
ISO 7388/2 A DIN 69872	201430250500	50	28	21	M24	25	74	34	15°	2
ISO 7388/2 A DIN 69872	201430250600	60	40	30	M30	32	90	40	15°	2

**ISO 7388/2 B - ANSI B.5 50**

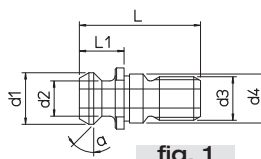

fig. 1

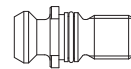
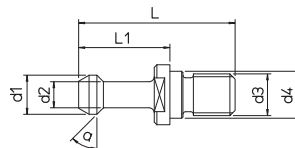

fig. 2

REF.	CODE	ISO	d1	d2	d3	d4	L	L1	a	fig.
ISO 7388/2 B ANSI B.5 50	201430251401	40	18.95	12.95	M16	17	44.50	16.40	45°	1
ISO 7388/2 B ANSI B.5 50	201430251451	45	24.05	16.30	M20	21	56	20.95	45°	1
ISO 7388/2 B ANSI B.5 50	201430251501	50	29.10	19.60	M24	25	65.50	25.55	45°	1
ISO 7388/2 B ANSI B.5 50	201430251400	40	18.95	12.95	M16	17	44.50	16.40	45°	2
ISO 7388/2 B ANSI B.5 50	201430251500	50	29.10	19.60	M24	25	65.50	25.55	45°	2

**MAS 403 BT - 30° - 45°**



REF.	CODE	ISO	d1	d2	d3	d4	L	L1	a
MAS 403 BT 30°	201430252301	30	11	7	M12	12.5	43	23	30°
MAS 403 BT 30°	201430252401	40	15	10	M16	17	60	35	30°
MAS 403 BT 30°	201430252451	45	19	14	M20	21	70	40	30°
MAS 403 BT 30°	201430252501	50	23	17	M24	25	85	45	30°
MAS 403 BT 30°	201430252601	60	32	24	M30	31	115	65	30°
MAS 403 BT 45°	201430252302	30	11	7	M12	12.5	43	23	45°
MAS 403 BT 45°	201430252402	40	15	10	M16	17	60	35	45°
MAS 403 BT 45°	201430252452	45	19	14	M20	21	70	40	45°
MAS 403 BT 45°	201430252502	50	23	17	M24	25	85	45	45°
MAS 403 BT 45°	201430252602	60	32	24	M30	31	115	65	45°

**HSK**

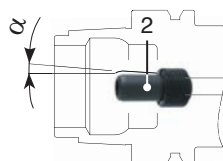

REF.	CODE 1	CODE 2	alpha
HSK-A40	101501101000	382019008001	± 1°
HSK-A50	101501101400	382019010001	± 1°
HSK-A63	101501101600	382019012001	± 1°
HSK-A80	101501101800	382019014001	± 1°
HSK-A100	101501102200	382019016001	± 1°
HSK-A125	101501102800	382019018000	± 1°

## ET-1- ER PINZE DI MASCHIATURA CON COMPENSAZIONE ASSIALE



REF.	CODE	d	D1	L	E	
ET-1-ER25 (M2-M12)	496086125280	2.8	26	34	8	100451012500
ET-1-ER25 (M2-M12)	496086125350	3.5	26	34	8	100451012500
ET-1-ER25 (M2-M12)	496086125450	4.5	26	34	8	100451012500
ET-1-ER25 (M2-M12)	496086125600	6	26	34	8	100451012500
ET-1-ER25 (M2-M12)	496086125700	7	26	34	8	100451012500
ET-1-ER25 (M2-M12)	496086125900	9	26	34	8	100451012500
ET-1-ER32 (M4-M16)	496086132450	4.5	33	43	10	100451033200
ET-1-ER32 (M4-M16)	496086132600	6	33	43	10	100451033200
ET-1-ER32 (M4-M16)	496086132700	7	33	43	10	100451033200
ET-1-ER32 (M4-M16)	496086132900	9	33	43	10	100451033200
ET-1-ER32 (M4-M16)	496086132110	11	33	43	10	100451033200
ET-1-ER32 (M4-M16)	496086132210	12	33	43	10	100451033200
ET-1-ER40 (M8-M20)	496086140600	6	41	54	13	100451034000
ET-1-ER40 (M8-M20)	496086140700	7	41	54	13	100451034000
ET-1-ER40 (M8-M20)	496086140900	9	41	54	13	100451034000
ET-1-ER40 (M8-M20)	496086140110	11	41	54	13	100451034000
ET-1-ER40 (M8-M20)	496086140120	12	41	54	13	100451034000
ET-1-ER40 (M8-M20)	496086140140	14	41	54	13	100451034000
ET-1-ER40 (M8-M20)	496086140160	16	41	54	13	100451034000

Fornibili su richiesta

## ER - GB PINZE PER MASCHIATURA RIGIDA



REF.	CODE	(dxc)	DIN 371	DIN 374-376	D1	L	
ER 16-GB (M4-M10)	496085116045	4.5 x 3.4	M4	M6	16	27.5	100451011600
ER 16-GB (M4-M10)	496085116055	5.5 x 4.3		M7	16	27.5	100451011600
ER 16-GB (M4-M10)	496085116060	6 x 4.9	M5	M8	16	27.5	100451011600
ER 16-GB (M4-M10)	496085116060	6 x 4.9	M6	M8	16	27.5	100451011600
ER 16-GB (M4-M10)	496085116070	7 x 5.5	M6	M10	16	27.5	100451011600
ER 25-GB (M4-M16)	496085125045	4.5 x 3.4	M4	M6	25	34	100451012500
ER 25-GB (M4-M16)	496085125055	5.5 x 4.3		M7	25	34	100451012500
ER 25-GB (M4-M16)	496085125060	6 x 4.9	M5	M8	25	34	100451012500
ER 25-GB (M4-M16)	496085125060	6 x 4.9	M6	M8	25	34	100451012500
ER 25-GB (M4-M16)	496085125070	7 x 5.5		M10	25	34	100451012500
ER 25-GB (M4-M16)	496085125090	9 x 7		M12	25	34	100451012500
ER 25-GB (M4-M16)	496085125110	11 x 9		M14	25	34	100451012500
ER 25-GB (M4-M16)	496085125120	12 x 9		M16	25	34	100451012500
ER 32-GB (M4-M20)	496085132045	4.5 x 3.4	M4	M6	32	40	100451033200
ER 32-GB (M4-M20)	496085132055	5.5 x 4.3		M7	32	40	100451033200
ER 32-GB (M4-M20)	496085132060	6 x 4.9	M5	M8	32	40	100451033200
ER 32-GB (M4-M20)	496085132060	6 x 4.9	M6	M8	32	40	100451033200
ER 32-GB (M4-M20)	496085132070	7 x 5.5		M10	32	40	100451033200
ER 32-GB (M4-M20)	496085132090	9 x 7		M12	32	40	100451033200
ER 32-GB (M4-M20)	496085132110	11 x 9		M14	32	40	100451033200
ER 32-GB (M4-M20)	496085132120	12 x 9		M16	32	40	100451033200
ER 32-GB (M4-M20)	496085132140	14 x 11		M18	32	40	100451033200
ER 32-GB (M4-M20)	496085132160	16 x 12		M20	32	40	100451033200
ER 40-GB (M10-M27)	496085140070	7 x 5.5		M10	40	46	100451034000
ER 40-GB (M10-M27)	496085140090	9 x 7		M12	40	46	100451034000
ER 40-GB (M10-M27)	496085140110	11 x 9		M14	40	46	100451034000
ER 40-GB (M10-M27)	496085140120	12 x 9		M16	40	46	100451034000
ER 40-GB (M10-M27)	496085140140	14 x 11		M18	40	46	100451034000
ER 40-GB (M10-M27)	496085140160	16 x 12		M20	40	46	100451034000
ER 40-GB (M10-M27)	496085140180	18 x 14.5		M22	40	46	100451034000
ER 40-GB (M10-M27)	496085140180	18 x 14.5		M24	40	46	100451034000
ER 40-GB (M10-M27)	496085140200	20 x 16		M27	40	46	100451034000

Fornibili su richiesta

## BFC BUSSOLE A CAMBIO RAPIDO SENZA LIMITAZIONE DI COPPIA

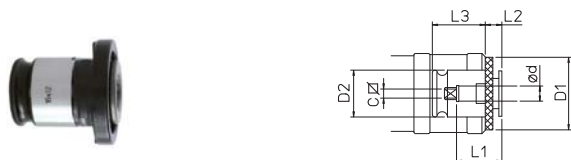

REF.	CODE	(dxc)	DIN 371	DIN 374	DIN 376	D1	D2	L1	L2	L3
BFC1 (M3 - 12)	495061035027	3.5 x 2.7	M3	M5	M5	30	19	17	7	21.5
BFC1 (M3 - 12)	495061045034	4.5 x 3.4	M4	M6	M6	30	19	17	7	21.5
BFC1 (M3 - 12)	495061055043	5.5 x 4.3		M7	M7	30	19	17	7	21.5
BFC1 (M3 - 12)	495061060049	6 x 4.9	M5	M8	M8	30	19	17	7	21.5
BFC1 (M3 - 12)	495061060049	6 x 4.9	M6	M8	M8	30	19	17	7	21.5
BFC1 (M3 - 12)	495061070055	7 x 5.5		M10	M10	30	19	17	7	21.5
BFC1 (M3 - 12)	495061090070	9 x 7		M12	M12	30	19	17	7	21.5
BFC2 (M6 - 20)	495062060049	6 x 4.9	M5	M8	M8	48	31	30	11	35
BFC2 (M6 - 20)	495062060049	6 x 4.9	M6	M8	M8	48	31	30	11	35
BFC2 (M6 - 20)	495062070055	7 x 5.5		M10	M10	48	31	30	11	35
BFC2 (M6 - 20)	495062090070	9 x 7		M12	M12	48	31	30	11	35
BFC2 (M6 - 20)	495062110090	11 x 9		M14	M14	48	31	30	11	35
BFC2 (M6 - 20)	495062120090	12 x 9		M16	M16	48	31	30	11	35
BFC2 (M6 - 20)	495062140110	14 x 11		M18	M18	48	31	30	11	35
BFC2 (M6 - 20)	495062160120	16 x 12		M20	M20	48	31	30	11	35
BFC3 (M14 - 33)	495063110090	11 x 9		M14	M14	70	48	44	14	55.5
BFC3 (M14 - 33)	495063120090	12 x 9		M16	M16	70	48	44	14	55.5
BFC3 (M14 - 33)	495063140110	14 x 11		M18	M18	70	48	44	14	55.5
BFC3 (M14 - 33)	495063160120	16 x 12		M20	M20	70	48	44	14	55.5
BFC3 (M14 - 33)	495063180145	18 x 14.5		M22	M22	70	48	44	14	55.5
BFC3 (M14 - 33)	495063180145	18 x 14.5		M24	M24	70	48	44	14	55.5
BFC3 (M14 - 33)	495063200160	20 x 16		M27	M27	70	48	44	14	55.5
BFC3 (M14 - 33)	495063220180	22 x 18		M30	M30	70	48	44	14	55.5
BFC3 (M14 - 33)	495063250200	25 x 20		M33	M33	70	48	44	14	55.5

Fornibili su richiesta

## BFS BUSSOLE A CAMBIO RAPIDO CON LIMITAZIONE DI COPPIA

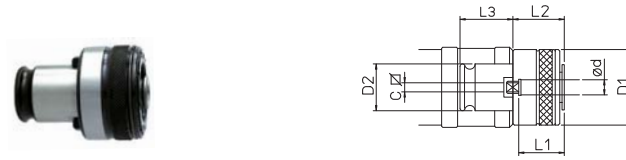

REF.	CODE	(dxc)	DIN 371	DIN 374	DIN 376	D1	D2	L1	L2	L3
BFS1 (M3 - 12)	495071035027	3.5 x 2.7	M3	M5	M5	32	19	17	25	21.5
BFS1 (M3 - 12)	495071040030	4 x 3	M3.5			32	19	17	25	21.5
BFS1 (M3 - 12)	495071045034	4.5 x 3.4	M4	M6	M6	32	19	17	25	21.5
BFS1 (M3 - 12)	495071055043	5.5 x 4.3		M7	M7	32	19	17	25	21.5
BFS1 (M3 - 12)	495071060049	6 x 4.9	M5	M8	M8	32	19	17	25	21.5
BFS1 (M3 - 12)	495071060049	6 x 4.9	M6	M8	M8	32	19	17	25	21.5
BFS1 (M3 - 12)	495071070055	7 x 5.5		M10	M10	32	19	17	25	21.5
BFS1 (M3 - 12)	495071080062	8 x 6.2		M8		32	19	17	25	21.5
BFS1 (M3 - 12)	495071090070	9 x 7		M12	M12	32	19	17	25	21.5
BFS1 (M3 - 12)	495071100080	10 x 8		M10		32	19	17	25	21.5
BFS2 (M6 - 20)	495072060049	6 x 4.9	M5	M8	M8	50	31	30	34	35
BFS2 (M6 - 20)	495072060049	6 x 4.9	M6	M8	M8	50	31	30	34	35
BFS2 (M6 - 20)	495072070055	7 x 5.5		M10	M10	50	31	30	34	35
BFS2 (M6 - 20)	495072080062	8 x 6.2		M8		50	31	30	34	35
BFS2 (M6 - 20)	495072090070	9 x 7		M12	M12	50	31	30	34	35
BFS2 (M6 - 20)	495072100080	10 x 8		M10		50	31	30	34	35
BFS2 (M6 - 20)	495072110090	11 x 9		M14	M14	50	31	30	34	35
BFS2 (M6 - 20)	495072120090	12 x 9		M16	M16	50	31	30	34	35
BFS2 (M6 - 20)	495072140110	14 x 11		M18	M18	50	31	30	34	35
BFS2 (M6 - 20)	495072160120	16 x 12		M20	M20	50	31	30	34	35
BFS3 (M14 - 33)	495073110090	11 x 9		M14	M14	72	48	44	45	55.5
BFS3 (M14 - 33)	495073120090	12 x 9		M16	M16	72	48	44	45	55.5
BFS3 (M14 - 33)	495073140110	14 x 11		M18	M18	72	48	44	45	55.5
BFS3 (M14 - 33)	495073160120	16 x 12		M20	M20	72	48	44	45	55.5
BFS3 (M14 - 33)	495073180145	18 x 14.5		M22	M22	72	48	44	45	55.5
BFS3 (M14 - 33)	495073180145	18 x 14.5		M24	M24	72	48	44	45	55.5
BFS3 (M14 - 33)	495073200160	20 x 16		M27	M27	72	48	44	45	55.5
BFS3 (M14 - 33)	495073220180	22 x 18		M30	M30	72	48	44	45	55.5
BFS3 (M14 - 33)	495073250200	25 x 20		M33	M33	72	48	44	45	55.5

Fornibili su richiesta



## ER DIN 6499-B

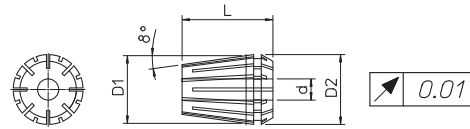

REF.	d	D1	D2	L
<b>ER 11</b>	0.5 ~ 7	11	11.5	18
<b>ER 16</b>	0.5 ~ 10	16	17	27.5
<b>ER 20</b>	1 ~ 13	20	21	31.5
<b>ER 25</b>	1 ~ 16	25	26	34
<b>ER 32</b>	2 ~ 20	32	33	40
<b>ER 40</b>	3 ~ 26	40	41	46

RANGE	CODE ER11	CODE ER16	CODE ER20	CODE ER25	CODE ER32	CODE ER40
1 - 0.5	496080111010	496080116010				
1.5 - 1	496080111015	496080116015				
2 - 1			496080120020			
2 - 1.5	496080111020	496080116021		496080125021		
2.5 - 2	496080111025	496080116025				
3 - 2		496080116030	496080120030	496080125030	496080132030	
3 - 2.5	496080111030					
3.5 - 3	496080111035					
4 - 3		496080116040	496080120040	496080125040	496080132040	496080140040
4 - 3.5	496080111040					
4.5 - 4	496080111045					
5 - 4		496080116050	496080120050	496080125050	496080132050	496080140050
5 - 4.5	496080111050					
5.5 - 5	496080111055					
6 - 5		496080116060	496080120060	496080125060	496080132060	496080140060
6 - 5.5	496080111060					
6.5 - 6	496080111065					
7 - 6		496080116070	496080120070	496080125070	496080132070	496080140070
7 - 6.5	496080111070					
8 - 7		496080116080	496080120080	496080125080	496080132080	496080140080
9 - 8		496080116090	496080120090	496080125090	496080132090	496080140090
10 - 9		496080116100	496080120100	496080125100	496080132100	496080140100
11 - 10			496080120110	496080125110	496080132110	496080140110
12 - 11			496080120120	496080125120	496080132120	496080140120
13 - 12			496080120130	496080125130	496080132130	496080140130
14 - 13				496080125140	496080132140	496080140140
15 - 14				496080125150	496080132150	496080140150
16 - 15				496080125160	496080132160	496080140160
17 - 16					496080132170	496080140170
18 - 17					496080132180	496080140180
19 - 18					496080132190	496080140190
20 - 19					496080132200	496080140200
21 - 20						496080140210
22 - 21						496080140220
23 - 22						496080140230
24 - 23						496080140240
25 - 24						496080140250
26 - 25						496080140260

Fornibili su richiesta pinze ER a TENUTA

### SET ER



REF.	Ø	CODE
<b>SET ER11/13</b>	0.5 ~ 7	496080111000
<b>SET ER16/10</b>	0.5 ~ 10	496080116000
<b>SET ER20/12</b>	1 ~ 13	496080120000
<b>SET ER25/15</b>	1 ~ 16	496080125000
<b>SET ER32/18</b>	2 ~ 20	496080132000
<b>SET ER40/23</b>	3 ~ 26	496080140000

ER DIN 6499-B

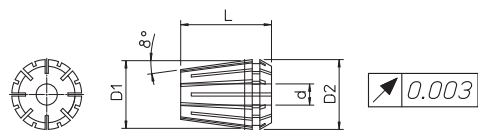

REF.	d	D1	D2	L
<b>ER 16</b>	0.5 ~ 10	16	17	27.5
<b>ER 25</b>	1 ~ 16	25	26	34
<b>ER 32</b>	2 ~ 20	32	33	40
<b>ER 40</b>	3 ~ 26	40	41	46

RANGE	CODE ER16	CODE ER25	CODE ER32	CODE ER40
1 - 0.5	496080016010			
1.5 - 1 •	496080016015			
2 - 1.5	496080016020	496080025020		
2.5 - 2 •	496080016025	496080025025	496080032025	
3 - 2.5	496080016030	496080025030	496080032030	
3.5 - 3 •	496080016035	496080025035	496080032035	
4 - 3.5	496080016040	496080025040	496080032040	496080040040
4.5 - 4 •	496080016045	496080025045	496080032045	496080040045
5 - 4.5	496080016050	496080025050	496080032050	496080040050
5.5 - 5 •	496080016055	496080025055	496080032055	496080040055
6 - 5.5	496080016060	496080025060	496080032060	496080040060
6.5 - 6 •	496080016065	496080025065	496080032065	496080040065
7 - 6.5	496080016070	496080025070	496080032070	496080040070
7.5 - 7 •	496080016075	496080025075	496080032075	496080040075
8 - 7.5	496080016080	496080025080	496080032080	496080040080
8.5 - 8 •	496080016085	496080025085	496080032085	496080040085
9 - 8.5	496080016090	496080025090	496080032090	496080040090
9.5 - 9 •	496080016095	496080025095	496080032095	496080040095
10 - 9.5	496080016100	496080025100	496080032100	496080040100
10.5 - 10 •		496080025105	496080032105	496080040105
11 - 10.5		496080025110	496080032110	496080040110
11.5 - 11 •		496080025115	496080032115	496080040115
12 - 11.5		496080025120	496080032120	496080040120
12.5 - 12 •		496080025125	496080032125	496080040125
13 - 12.5		496080025130	496080032130	496080040130
13.5 - 13 •		496080025135	496080032135	496080040135
14 - 13.5		496080025140	496080032140	496080040140
14.5 - 14 •		496080025145	496080032145	496080040145
15 - 14.5		496080025150	496080032150	496080040150
15.5 - 15 •		496080025155	496080032155	496080040155
16 - 15.5		496080025160	496080032160	496080040160
16.5 - 16 •			496080032165	496080040165
17 - 16.5			496080032170	496080040170
17.5 - 17 •			496080032175	496080040175
18 - 17.5			496080032180	496080040180
18.5 - 18 •			496080032185	496080040185
19 - 18.5			496080032190	496080040190
19.5 - 19 •			496080032195	496080040195
20 - 19.5			496080032200	496080040200
20.5 - 20 •				496080040205
21 - 20.5				496080040210
21.5 - 21 •				496080040215
22 - 21.5				496080040220
22.5 - 22 •				496080040225
23 - 22.5				496080040230
23.5 - 23 •				496080040235
24 - 23.5				496080040240
24.5 - 24 •				496080040245
25 - 24.5				496080040250
25.5 - 25 •				496080040255
26 - 25.5				496080040260

• Fornibili su richiesta

Fornibili su richiesta pinze ER a TENUTA





**SYSTEM MHD'**

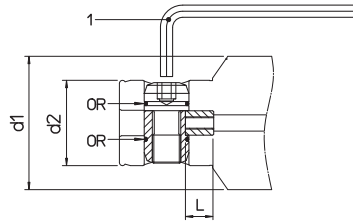

**fig. 1**

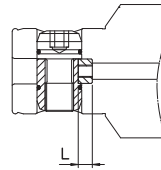

**fig. 2**

REF.	CODE	d1	d2	CODE 1	CODE OR	L	fig.
MHD' 14	381725001161	14	10	101500100250		2	2
MHD' 16	381725001161	16	10	101500100250		2	2
MHD' 20	381725001201	20	13	101500100300		2.5	2
MHD' 25	381725001251	25	16	101500100300		3	2
MHD' 32	381725001321	32	20	101500100400	101254007510	3.55	2
MHD' 40	381725001401	40	25	101500100500	101254010010	4	2
MHD' 50 RD 50 / .. TRD - TRM - TRC - TR-E	381725001501	50	32	101500100600	101254013010	4.2	2
MHD' 50	381725001001	50	32	101500100600	101254013010	12.2	1
MHD' 63-80	381725001002	63-80	42	101500100800	101251002075	13.85	1
MHD' 110 - 140	381725001003	110-140	76	101500101400	101251003112	10	1

**TS**

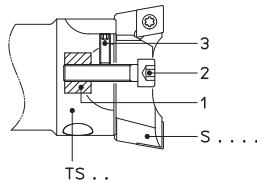

**fig. 1**

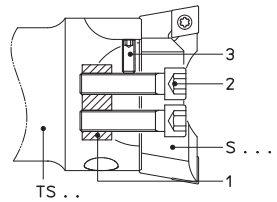

**fig. 2**

REF.	CODE 1	CODE 2	CODE 3	fig.
TS 16/16	201430110008	100051030014	100231030004	1
TS 20/20	201430110009	100051040015	100231030005	1
TS 25/25	201430110010	100051040020	100231030008	1
TS 32/32	201430110011	100051050025	100231040012	1
TS 40/40	201430110012	100051060030	100231050014	1
TS 50/50	201430110013	100051080035	100231050012	2
TS 50/63	201430110014	100051100040	100231060016	2
TS 63/63	201430110014	100051100040	100231060016	2
TS 80/80	201430110015	100051120045	100231080025	2

**TRD**

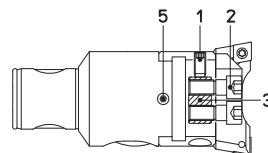
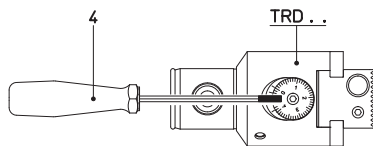

REF.	CODE 1	CODE 2	CODE 3	CODE 4	CODE 5
TRD 25	100231040008	200100150411	201430110024	101500800200	100271040004
TRD 32	100231050010	200100150512	201430110023	101500800250	100271050006
TRD 40	100231060012	200100150616	201430170001	101500800300	100271060006
TRD 50	100231060014	200100150820	201430110021	101500800300	100271060008
TRD 63	100231060016	200100151026	201430110026	101500800300	100271060008
TRD 80	100231060020	200100151230	201430110022	101500800300	100271060012

**TRM**

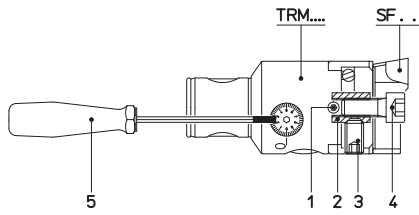

**fig. 1**

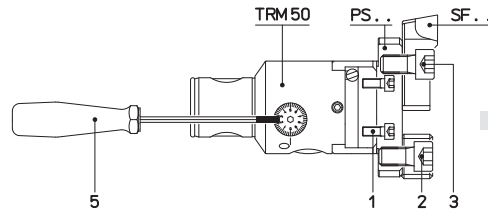

**fig. 2**

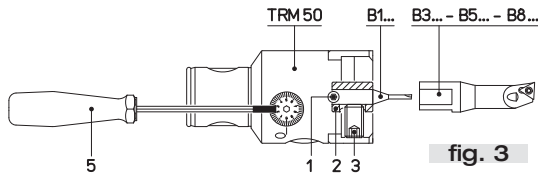

**fig. 3**

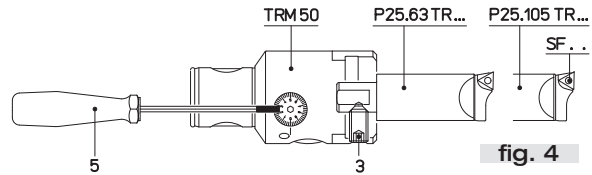

**fig. 4**

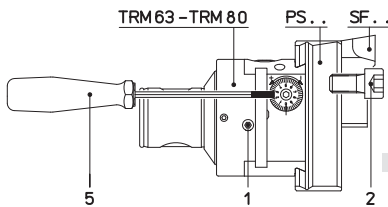

**fig. 5**

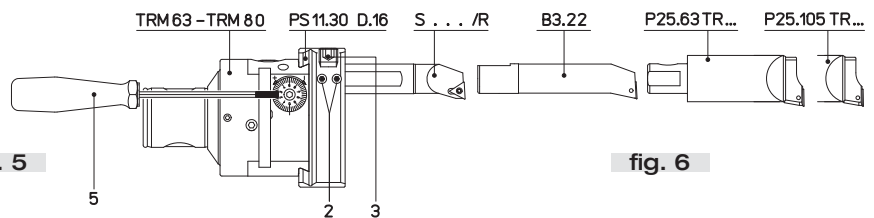

**fig. 6**

REF.	CODE 1	CODE 2	CODE 3	CODE 4	CODE 5	fig.
TRM 16	200100190301			100051030006	101500800150	1
TRM 20	200100190301			100051040008	101500800150	1
TRM 25	100271040004			100051050010	101500800200	1
TRM 32	100231040006			100051060012	101500800200	1
TRM 40	100271050006			100051080014	101500800250	1
TRM 50	100271050008	201041015002	100231100016	100051100025	101500800250	1
TRM 50	200100150501	100051100020	100051100025		101500800250	2
TRM 50	100271050008	200560116082	100231100016		101500800250	3-4
TRM 63	100251060010	100051100018			101500800300	5
TRM 80	100251060014	100051100018			101500800300	5
TRM 125	100251060020	100051100025			101500800300	5
TRM 63	100251060010	100231050006	100231100010		101500800300	6
TRM 80	100251060014	100231050006	100231100010		101500800300	6

**TRM 32 - 50 HSB**

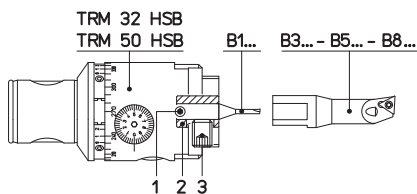

REF.	CODE 1	CODE 2	CODE 3
TRM 32 HSB	100271040005		100231050008 - 100231050012
TRM 50 HSB	100271050008	200560116082	100231100010

**TRC**

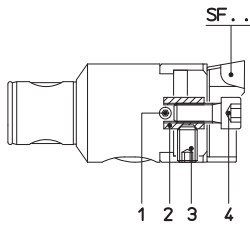
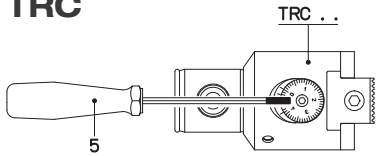

fig. 1

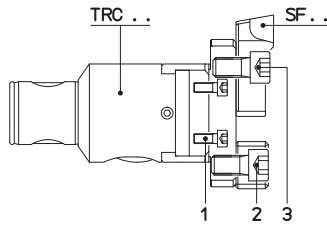

fig. 2

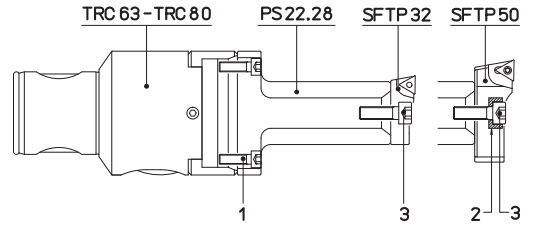

fig. 3

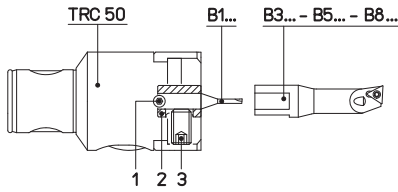

fig. 4

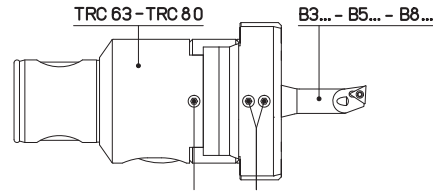

fig. 4

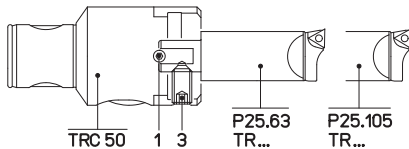
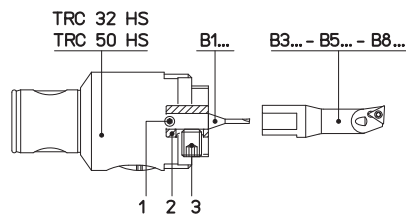

fig. 4

REF.	CODE 1	CODE 2	CODE 3	CODE 4	CODE 5	fig.
TRC 14	200100190302			100051030006	101500800150	1
TRC 16	200100190301			100051030006	101500800150	1
TRC 20	200100190301			100051040008	101500800150	1
TRC 25	100271040004			100051050010	101500800150	1
TRC 32	100271050005			100051060012	101500800250	1
TRC 40	100271060006			100051080014	101500800300	1
TRC 50	100271060008	201041015002	100231100016	100051100025	101500800300	1
TRC 63	100271060008			100051100020	101500800300	1
TRC 80	100271060012			100051100025	101500800300	1
TRC 50	200100150501	100051100020	100051100025			2
TRC 63	100051050025	100051100020	100051100025			2
TRC 80	100051050025	100051100020	100051100025			2
TRC 63	100051050016	201040607001	100051006020			3
TRC 80	100051050016	201040607001	100051006020			3
TRC 50	100271060008	200560116082	100231100010			4
TRC 63	100271060008		100231060006			4
TRC 80	100271060012		100231060006			4

**TRC 32 - 50 HS**



REF.	CODE 1	CODE 2	CODE 3
TRC 32 HS	100271050006		100231050008 - 100231050012
TRC 50 HS	100271060008	200560116082	100231100010

## TRE

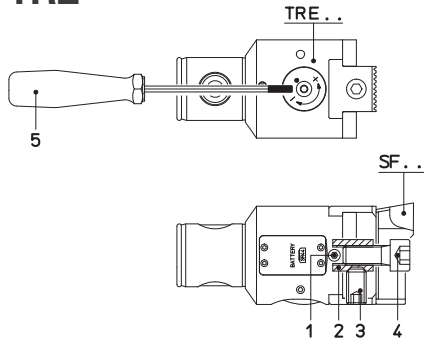

fig. 1

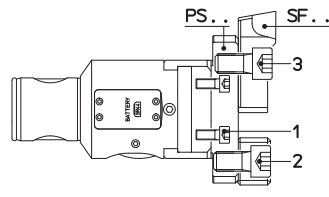

fig. 2

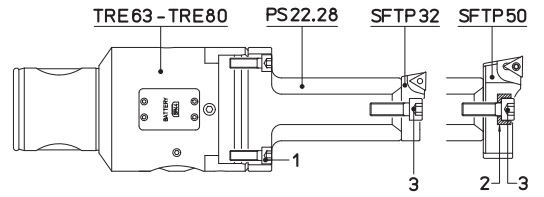

fig. 3

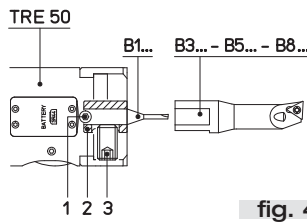

fig. 4

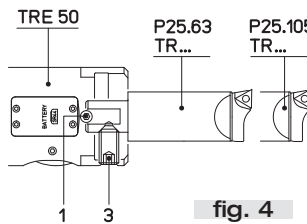
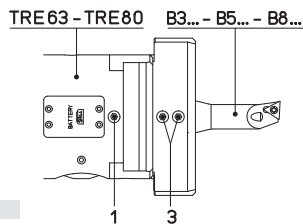
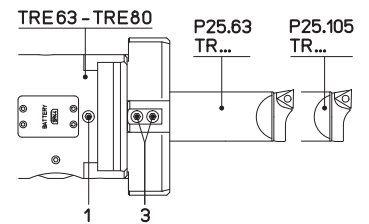
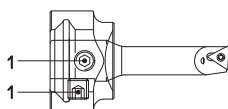

fig. 4



REF.	CODE 1	CODE 2	CODE 3	CODE 4	CODE 5	fig.
TRE 32	100238050007			100051060012	101500800250	1
TRE 40	100238050007			100051080014	101500800300	1
TRE 50	100238060010	201041015002	100231100016	100051100025	101500800250	1
TRE 63	100238060010			100051100020	101500800250	1
TRE 80	200100150614			100051100025	101500800250	1
TRE 50	200100150501	100051100020	100051100025			2
TRE 63	100051050025	100051100020	100051100025			2
TRE 80	100051050025	100051100020	100051100025			2
TRE 63	100051050016	201040607001	100051006020			3
TRE 80	100051050016	201040607001	100051006020			3
TRE 50	100238060010	200560116082	100231100016			4
TRE 63	100238060010		100231060006			4
TRE 80	200100150614		100231060006			4

## P 20.30



REF.	CODE 1
P20.30	100251080008

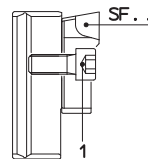

## PS

REF.	CODE 1
PS 11.30	100051100018
PS 12.30	100051100018
PS 13.30	100051100018
PS 11.40	100051100025
PS 12.40	100051100025
PS 13.40	100051100025
PS 14.40	100051100025

## PS

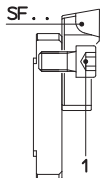

REF.	CODE 1
PS31.24	100051100020
PS31.28	100051100025
PS32.28	100051100025
PS33.28	100051100025

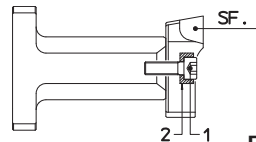

## P 22.28

REF.	CODE 1	CODE 2
P22.28	100051060020	201040607001

## P 25

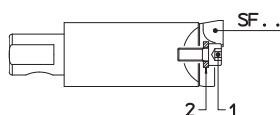

REF.	CODE 1	CODE 2
P25.63	100051050012	100800100530
P25.105	100051050012	100800100530

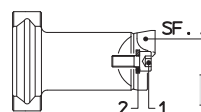

## P

REF.	CODE 1	CODE 2
P 02.30	100051050012	100800100530
P 03.30	100051050012	100800100530
P 04.30	100051050012	100800100530
P 02.40	100051060018	100800100640
P 03.40	100051060018	100800100640
P 04.40	100051060018	100800100640

**PF ER DIN 6499**

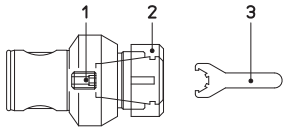

REF.	CODE 1	CODE 2	CODE 3
PE 16 / ER11M	200100190403	100451011100	101501001100
PE 20 / ER16M	200100190403	100451011600	101501001600
PE 25 / ER20M	200100190506	100451012000	101501002000
PE 32 / ER25M	200100190608	100451012500	101501002500
PE 40 / ER25	200100190808	100451032500	101501002501
PE 50 / ER25	200100190808	100451032500	101501002501
PE 50 / ER32	200100190808	100451033200	101501003201
PE 63 / ER32	200100191014	100451033200	101501003201
PE 63 / ER40	200100191214	100451034000	101501004001

**AW DIN 1835 B-E**

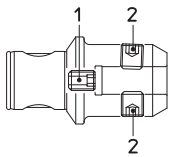

REF.	CODE 1	CODE 2
AW 50/6	200100190808	200100190610
AW 50/8	200100190808	200100190810
AW 50/10	200100190809	200100191012
AW 50/12	200100190809	200100191216
AW 50/14	200100190809	200100191216
AW 50/16	200100191215	200100191416
AW 50/20	200100191215	200100191616
AW 50/25	200100191615	200100191820
AW 63/16	200100191215	200100191416
AW 63/20	200100191215	200100191616
AW 63/25	200100191615	200100191820
AW 63/32	200100191615	200100192020
AW 80/40	200100192019	200100192020

**PF**

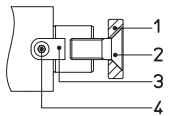

REF.	CODE 1	CODE 2	CODE 3	CODE 4	CODE 5
PF 50/16 PF 40/16	201010085010	201101800801	101001040014	100101080025	100051030008
PF 50/22 PF 40/22	201010105030	201101801002	101001060016	100101100025	100051040010
PF 50/27	201010125030	201101801202	101001070018	100101120030	100051050012
PF 50/32	201010165020	201101801402	101001080020	100101160035	100051060016
PF 63/22	201010105030	201101801002	101001060016	100101100025	100051040010
PF 63/27	201010125030	201101801202	101001070018	100101120030	100051050012
PF 63/32	201010165020	201101801402	101001080020	100101160035	100051060016
PF 80/32	201010165020	201101801402	101001080020	100101160035	100051060016
PF 80/40	201010210010	201101801603	101001100025	100101200045	100051060018
PF 80/50	201010260330	201101801802	101001120028	100101240050	100051060020
PF 80/60		201101802510	101001140036		100051120025
PF 110/40	201010210010	201101801603	101001100025	100101200045	100051060018
PF 110/60		201101802510	101001140036		100051120025
PF 140/40	201010210010	201101801603	101001100025	100101200045	100051060018
PF 140/60		201101802510			100051120025

**CM DIN 228 A**

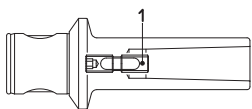

REF.	CODE 1
CM 50/1	201081506003
CM 50/2	201081510002
CM 50/3	201081512004
CM 63/3	201081512004
CM 63/4	201081516001

**AM**

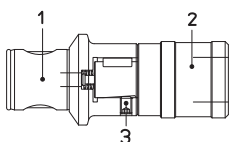

REF.	REF. 1	CODE 1	REF. 2	CODE 2	CODE 3
AM 50/M3-12	RAM 50/M3-12	456505000100	WFLK 115B/A 308	495090010312	100231060008
AM 50/M8-20	RAM 50/M8-20	456505000200	WFLK 225B/A 308	495090020820	100231080012
AM 63/M3-12	RAM 63/M3-12	456506300100	WFLK 115B/A 308	495090010312	100231060008
AM 63/M8-20	RAM 63/M8-20	456506300200	WFLK 225B/A 308	495090020820	100231080012



**BPS**

**SGROSSATURA**

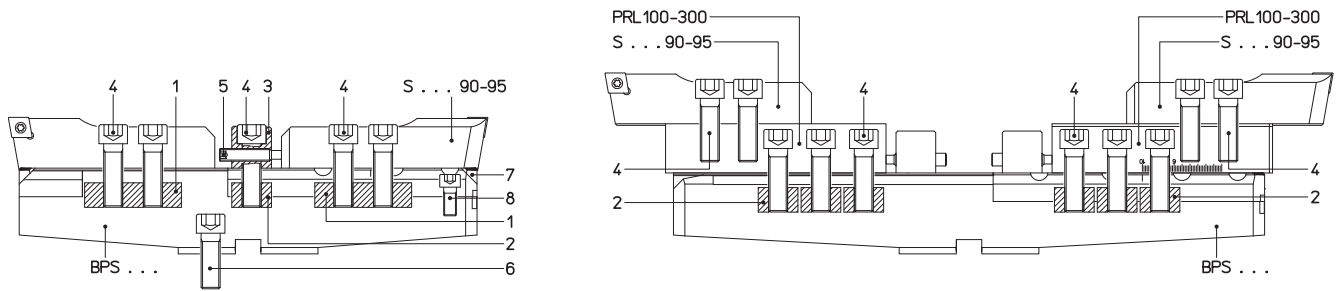

REF.	CODE 1	CODE 2	CODE 3	CODE 4	CODE 5	CODE 6	CODE 7	CODE 8
<b>BPS 200</b>	201430110017	201430110016	201100502601	100051120040	100251080040	100051120035	200655015707	100051080025
<b>BPS 300</b>	201430110017	201430110016	201100502601	100051120040	100251080040	100051120035	200655015708	100051080025
<b>BPS 400</b>	201430110017	201430110016	201100502601	100051120040	100251080040	100051120035	200655016301	100051080020
<b>BPS 500</b>	201430110017	201430110016	201100502601	100051120040	100251080040	100051160050	200655016301	100051080025
<b>BPS 600</b>	201430110017	201430110016	201100502601	100051120040	100251080040	100051160050	200655016301	100051080025
<b>BPS 700</b>	201430110017	201430110016	201100502601	100051120040	100251080040	100051160050	200655016301	100051080025
<b>BPS 800</b>	201430110017	201430110016	201100502601	100051120040	100251080040	100051160050	200655016301	100051080025

**BPS**

**FINITURA**

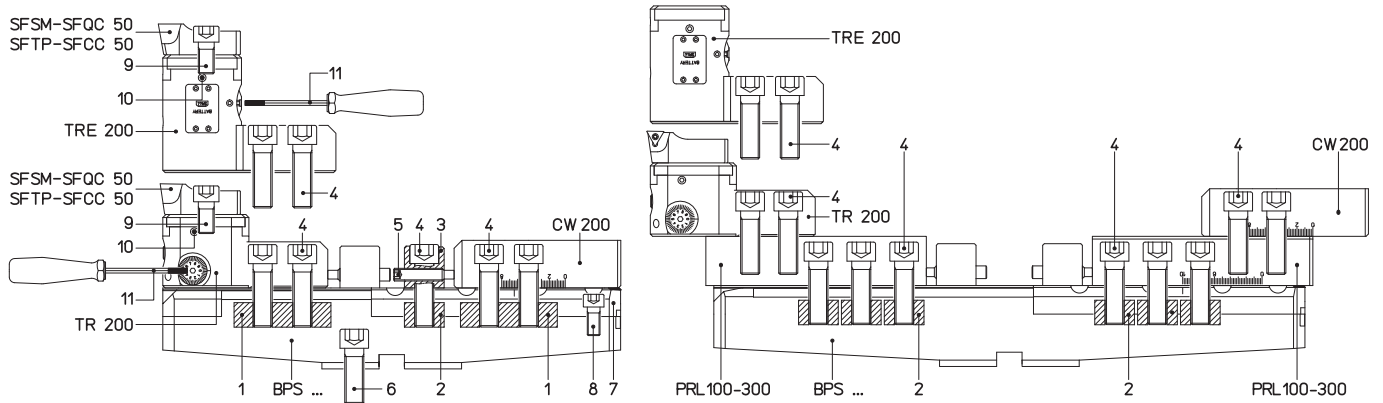

REF.	CODE 1	CODE 2	CODE 3	CODE 4	CODE 5	CODE 6
<b>BPS 200-300-400</b>	201430110017	201430110016	201100502601	100051120040	100251080040	100051120035
<b>BPS 500-600-700-800</b>	201430110017	201430110016	201100502601	100051120040	100251080040	100051160050

REF.	CODE 7	CODE 8	CODE 9	CODE 10	CODE 11
<b>BPS 200</b>	200655015707	100051080025	100051100020	100251060008	101500800300
<b>BPS 300</b>	200655015708	100051080025	100051100020	100251060008	101500800300
<b>BPS 400</b>	200655016301	100051080020	100051100020	100251060008	101500800300
<b>BPS 500-600-700-800</b>	200655016301	100051080025	100051100020	100251060008	101500800300

**SS.. 95**

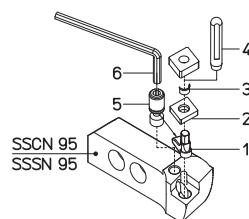

REF.	CODE 1	CODE 2	CODE 3	CODE 4	CODE 5	CODE 6
<b>SSCN 95</b>	491111190600	492031190600	100655095112	101501301408	494311190600	101500100400
<b>SSSN 95</b>	491111190600	492035190600	100655095112	101501301408	494311190600	101500100400

## FORCE GH - VT DISPOSITIVI A TENUTA PER REFRIGERANTE AD ALTA PRESSIONE

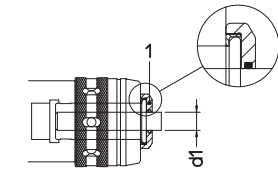

fig. 1

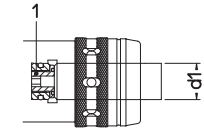

fig. 2

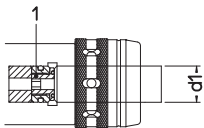
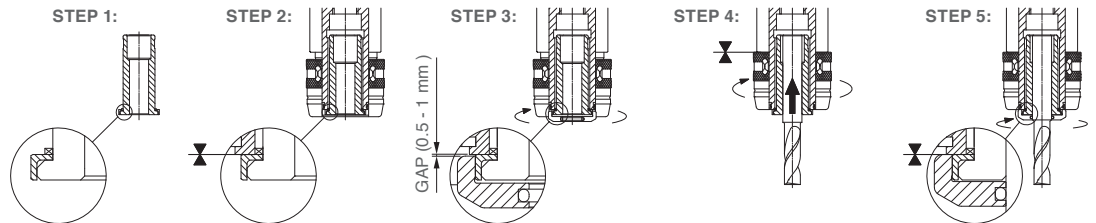

fig. 3

fig.	REF.	CODE 1	d1
1	GH 20 MONOforce 20 HSK63 MHD'50 / DIN/BT-40-50 PSC 63 - 80	382042020061	6
		382042020081	8
		382042020101	10
		382042020121	12
		382042020141	14
		382042020161	16
2	VT 20.20 MONOforce 20 DIN/BT-40-50 HSK63-100 PSC 63-80	382042020201	20
1	GH 32 MONOforce 32 DIN/BT-40-50 / HSK63-100 MHD'63 PSC 63-80	382042032061	6
		382042032081	8
		382042032101	10
		382042032121	12
		382042032141	14
		382042032161	16
		382042032181	18
		382042032201	20
		382042032251	25
2	VT 32.32 MONOforce 32 DIN/BT-40 HSK63-100 PSC 63-80	382042032321	32
3	VT 32.32.100 MONOforce 32 DIN/BT-50	382042032322	32



## FORCE VCR VITE REGOLAZIONE CON PASSAGGIO REFRIGERANTE

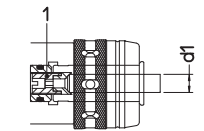

fig. 1

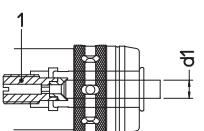
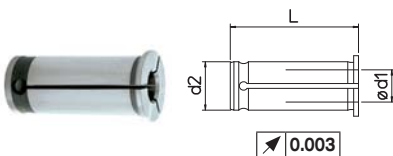

fig. 2

fig.	REF.	CODE 1	d1
1	VCR 20 MONOforce 20 HSK63-100 MHD'50 PSC 63-80	382041020032	3 ~ 5
		382041020062	6 ~ 12
		382041020142	14 ~ 20
1	VCR 32 MONOforce 32 HSK63-100 MHD'63 PSC 63-80	382041032033	3 ~ 5
		382041032063	6 ~ 12
		382041032143	14 ~ 20
		382041032253	25 ~ 32
		382041020031	3 ~ 5
2	VCR 20 MONOforce 20 DIN/BT-40-50	382041020061	6 ~ 12
		382041020141	14 ~ 20
		382041032031	3 ~ 5
2	VCR 32 MONOforce 32 DIN/BT-40	382041032061	6 ~ 12
		382041032141	14 ~ 20
		382041032251	25 ~ 32
		382041032032	3 ~ 5
		382041032062	6 ~ 12
2	VCR 32 MONOforce 32 DIN/BT-50	382041032142	14 ~ 20
		382041032252	25 ~ 32

## RC BUSSOLE MANDRINO A FORTE SERRAGGIO



FORCE (d2)	REF.	CODE	d1	L
12	RC 12.03	497080012030	3	44
12	RC 12.04	497080012040	4	44
12	RC 12.06	497080012060	6	44
12	RC 12.08	497080012080	8	44
12	RC 12.10	497080012100	10	44
20	RC 20.03	497080020030	3	50
20	RC 20.04	497080020040	4	50
20	RC 20.05	497080020050	5	50
20	RC 20.06	497080020060	6	50
20	RC 20.08	497080020080	8	50
20	RC 20.10	497080020100	10	50
20	RC 20.12	497080020120	12	50
20	RC 20.14	497080020140	14	50
20	RC 20.16	497080020160	16	50
32	RC 32.03	497080032030	3	63
32	RC 32.04	497080032040	4	63
32	RC 32.05	497080032050	5	63
32	RC 32.06	497080032060	6	63
32	RC 32.08	497080032080	8	63
32	RC 32.10	497080032100	10	63
32	RC 32.12	497080032120	12	63
32	RC 32.14	497080032140	14	63
32	RC 32.16	497080032160	16	63
32	RC 32.18	497080032180	18	63
32	RC 32.20	497080032200	20	63
32	RC 32.25	497080032250	25	63

Fornibili su richiesta bussole RC a TENUITA

**FORCE**

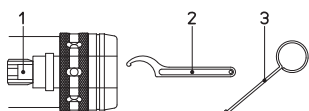

REF	CODE 1	CODE 2	CODE 3
<b>FORCE 12</b>	200100191014	101500400028	201271600400
<b>FORCE 20</b>	200100191615	101500400050	201271600400
<b>FORCE 32</b>	200100191615	101500400075	201271600400

**MONOd'**

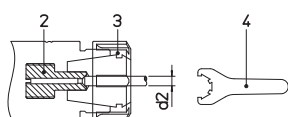
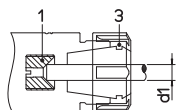

REF.	CODE 1	d1	CODE 2	d2	CODE 3	CODE 4
<b>ER 16 M</b>	201082010001	5 ~ 10	201082010002	1 ~ 4	100451011600	101501001600
<b>ER 25</b>	201082018001	8 ~ 16	201082018002	2 ~ 7	100451032500	101501002501
<b>ER 32</b>	201082022001	8 ~ 20	201082022002	3 ~ 7	100451033200	101501003201
<b>ER 40</b>	201082028001	9 ~ 26	201082028002	4 ~ 8	100451034000	101501004001

**MONOd' - WD**

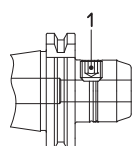

fig. 1

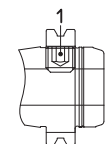
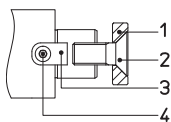

fig. 2

fig.	REF.	CODE 1
1	<b>WD 06</b>	200100190610
1	<b>WD 08</b>	200100190810
1	<b>WD 10</b>	200100191010
1	<b>WD 12</b>	200100191212
1	<b>WD 14</b>	200100191212
1	<b>WD 16</b>	200100191414
1	<b>WD 18</b>	200100191414
1	<b>WD 20</b>	200100191616
2	<b>WD 20</b>	200100191613
1	<b>WD 25</b>	200100191820
2	<b>WD 25</b>	200100191821
1	<b>WD 32</b>	200100192020
1	<b>WD 40</b>	200100192020

**MONOd' - PSC PF**



REF.	CODE 1	CODE 2	CODE 3	CODE 4
<b>PF 16</b>	201010085010	100101080025	201101800801	100051030008
<b>PF 22</b>	201010105030	100101100025	201101801002	100051040010
<b>PF 27</b>	201010125030	100101120030	201101801202	100051050012
<b>PF 32</b>	201010165020	100101160035	201101801402	100051060016
<b>PF 40</b>	201010210010	100101200045	201101801603	100051060018
<b>PF 60</b>			201101802510	100051120025

**PSC**

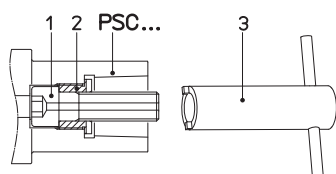

PSC	CODE 1	CODE 2	CODE 3
<b>32</b>	200101151240	201031815001	101501401800
<b>40</b>	200101151448	201032215005	101501402101
<b>50</b>	200101151658	201032515005	101501402401
<b>63</b>	200101152071	201033015021	101501403001
<b>80</b>	200101152071	201033015021	101501403001

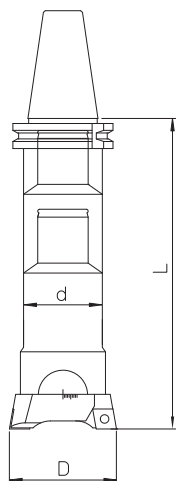
**DATI DI TAGLIO CONSIGLIATI PER SGROSSATURA DI FORI CON TESTINE BITAGLIANTI TS**

materiale	dimensioni bareno	condizioni di lavoro	velocità di taglio Vc = m/min. diametro			avanzamento f = mm/giro (due taglianti) raggio inserto		
			D < 38	D = 38-120	D > 120	R = 0.2	R = 0.4	R = 0.8
acciaio al carbonio HB ≤ 200	L / d = 2.5	buona	120 - 180	140 - 200	160 - 250		0.2 - 0.4	0.3 - 0.5
	L / d = 4	normale	100 - 160	120 - 180	140 - 200		0.2 - 0.4	0.3 - 0.5
	L / d = 6.3	difficile	70 - 100	70 - 100	70 - 100	0.15 - 0.3	0.2 - 0.4	
acciaio al carbonio HB > 200	L / d = 2.5	buona	100 - 160	120 - 180	140 - 200		0.2 - 0.4	0.3 - 0.5
	L / d = 4	normale	80 - 140	100 - 160	120 - 180		0.2 - 0.4	0.3 - 0.5
	L / d = 6.3	difficile	60 - 90	70 - 100	70 - 100	0.15 - 0.3	0.2 - 0.4	
acciaio inox AISI 304 - 316	L / d = 2.5	buona	80 - 110	90 - 120	100 - 140		0.2 - 0.4	0.3 - 0.5
	L / d = 4	normale	70 - 100	80 - 110	90 - 120		0.2 - 0.4	0.3 - 0.5
	L / d = 6.3	difficile	60 - 90	60 - 90	60 - 90	0.15 - 0.3	0.2 - 0.4	
ghisa	L / d = 2.5	buona	90 - 120	100 - 140	120 - 160		0.2 - 0.4	0.3 - 0.5
	L / d = 4	normale	70 - 100	90 - 120	100 - 140		0.2 - 0.4	0.3 - 0.5
	L / d = 6.3	difficile	60 - 90	60 - 90	60 - 90	0.15 - 0.3	0.2 - 0.4	
alluminio	L / d = 2.5	buona	160 - 250	200 - 300	250 - 350		0.3 - 0.5	0.4 - 0.6
	L / d = 4	normale	140 - 200	160 - 250	200 - 300		0.3 - 0.5	0.4 - 0.6
	L / d = 6.3	difficile	100 - 150	100 - 150	100 - 150	0.2 - 0.4	0.3 - 0.5	

profondità di passata ap = mm	campo di lavoro Ø = mm	max. profondità di passata acciaio ghisa, alluminio	
	18 - 28	1.5 - 2	2 - 2.5
	28 - 50	2 - 3	2.5 - 3.5
	50 - 68	3 - 4	3.5 - 5
	68 - 200	4 - 5	5 - 7
	200 - 500	5 - 6	6 - 8

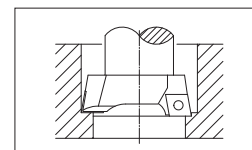
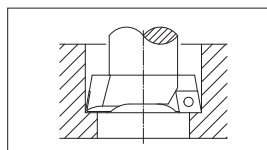

Due taglianti sullo stesso diametro Due taglianti su diametri diversi

È consigliabile che il preforo B sia ≥ al diametro del bareno d.

**ATTENZIONE:** Per lavorare con un solo tagliante o con differenti diametri di taglio, dimezzare l'avanzamento indicato in tabella.

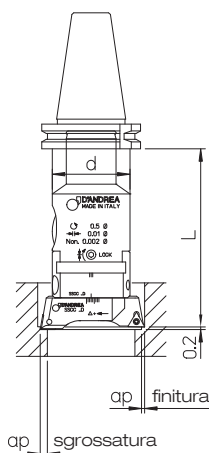
**DATI DI TAGLIO CONSIGLIATI PER ALESATURA CON TESTAROSSA BITAGLIANTE TRD**

materiale	dimensioni bareno	condizioni di lavoro	velocità di taglio Vc = m/min.	avanzamento fn = mm/giro raggio inserto		qualità inserto		profondità di passata			
				R = 0.2	R = 0.4	sgrossatura	finitura	ap finitura	ap sgrossatura ø28 ø46 ø75 ø160		
acciaio al carbonio HB ≤ 200	L / d = 2.5	buona	160 - 250	0.1 - 0.2	0.1 - 0.2	DC100 DP300	DP300 DP100R	0.15 - 0.3	1.5	2	2.5
	L / d = 4	normale	120 - 180	0.1 - 0.2	0.1 - 0.2						
	L / d = 6.3	difficile	70 - 100	*0.1 - 0.15	0.1 - 0.2						
acciaio al carbonio HB > 200	L / d = 2.5	buona	140 - 200	0.1 - 0.2	0.1 - 0.2	DC100	DP300 DP100R	0.15 - 0.3	1.5	2	2.5
	L / d = 4	normale	100 - 160	0.1 - 0.2	0.1 - 0.2						
	L / d = 6.3	difficile	70 - 100	*0.1 - 0.15	0.1 - 0.2						
acciaio inox AISI 304-316	L / d = 2.5	buona	100 - 140	0.1 - 0.2	0.1 - 0.2	DP300	DP300	0.15 - 0.3	1.5	2	2.5
	L / d = 4	normale	80 - 110	0.1 - 0.2	0.1 - 0.2						
	L / d = 6.3	difficile	60 - 90	*0.1 - 0.15	0.1 - 0.2						
ghisa	L / d = 2.5	buona	120 - 160	0.1 - 0.2	0.1 - 0.2	DK100 DC300	DP100R	0.15 - 0.3	2	2.5	3
	L / d = 4	normale	90 - 120	0.1 - 0.2	0.1 - 0.2						
	L / d = 6.3	difficile	60 - 90	*0.1 - 0.15	0.1 - 0.2						
alluminio	L / d = 2.5	buona	250 - 350	0.1 - 0.2	0.1 - 0.2	DK100	DK100	0.15 - 0.3	2	2.5	3
	L / d = 4	normale	160 - 250	0.1 - 0.2	0.1 - 0.2						
	L / d = 6.3	difficile	100 - 150	*0.1 - 0.15	0.1 - 0.2						

\* Solo per inserti di finitura

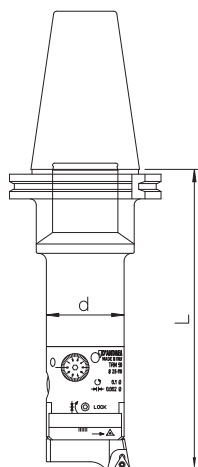
**DATI DI TAGLIO CONSIGLIATI PER L'ALESATURA CON TESTAROSSA TRM / TRC / TR-E**

materiale	dimensioni bareno	condizioni di lavoro	velocità di taglio Vc = m/min.	avanzamento fn = mm/giro raggio inserto			qualità inserto	profondità di passata
				R = 0.0	R = 0.2	R = 0.4		
acciaio al carbonio HB ≤ 200	L / d = 2.5	buona	200 - 300		0.05 - 0.08	0.07 - 0.1	DC100 DP300	
	L / d = 4	normale	160 - 250		0.05 - 0.08	0.07 - 0.1		
	L / d = 6.3	difficile	70 - 100	0.05 - 0.08	0.05 - 0.08			
acciaio al carbonio HB > 200	L / d = 2.5	buona	160 - 250		0.05 - 0.08	0.07 - 0.1	DC100	
	L / d = 4	normale	150 - 200		0.05 - 0.08	0.07 - 0.1		
	L / d = 6.3	difficile	70 - 100	0.05 - 0.08	0.05 - 0.08			
acciaio inox AISI 304 - 316	L / d = 2.5	buona	120 - 160		0.05 - 0.08	0.07 - 0.1	DP300	
	L / d = 4	normale	100 - 140		0.05 - 0.08	0.07 - 0.1		
	L / d = 6.3	difficile	70 - 100	0.05 - 0.08	0.05 - 0.08			
ghisa	L / d = 2.5	buona	120 - 160		0.05 - 0.08	0.07 - 0.1	DK100 DC100	
	L / d = 4	normale	100 - 140		0.05 - 0.08	0.07 - 0.1		
	L / d = 6.3	difficile	70 - 100	0.05 - 0.08	0.05 - 0.08			
alluminio	L / d = 2.5	buona	300 - 400		0.05 - 0.08	0.07 - 0.1	DK100	
	L / d = 4	normale	250 - 350		0.05 - 0.08	0.07 - 0.1		
	L / d = 6.3	difficile	100 - 150	0.05 - 0.08	0.05 - 0.08			
acciaio HB > 200	L / d = 2.5	buona	80 - 100		0.04 - 0.06	0.05 - 0.07	D20CBN	
	L / d = 4	normale	80 - 100		0.04 - 0.06	0.05 - 0.07		

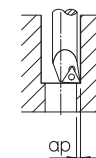

0.1 - 0.25 mm

**FORMULA DI CALCOLO PER ALESATURA**

**Vc** velocità di taglio (m/min.)  
**D** diametro del pezzo da lavorare (mm)  
**n** numero di giri al minuto (giri/min.)  
**Vf** velocità avanzamento (mm/min.)  
**fn** avanzamento al giro (mm/giro)  
**π** 3.14

$$Vc = \frac{\pi \cdot D \cdot n}{1000}$$

$$n = \frac{Vc \cdot 1000}{\pi \cdot D}$$

$$Vf = n \cdot fn$$

## HSK-A

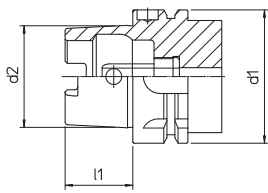

HSK-A	d1	d2	l1
32	32	24	16
40	40	30	20
50	50	38	25
63	63	48	32
80	80	60	40
100	100	75	50

## HSK-B

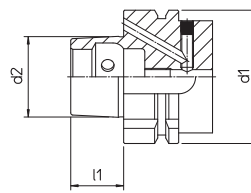

HSK-B	d1	d2	l1
-	-	-	-
40	40	24	16
50	50	30	20
63	63	38	25
80	80	48	32
100	100	60	40

## HSK-C

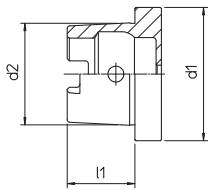

HSK-C	d1	d2	l1
32	32	24	16
40	40	30	20
50	50	38	25
63	63	48	32
80	80	60	40
100	100	75	50

## HSK-D

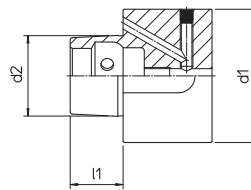

HSK-D	d1	d2	l1
-	-	-	-
40	40	24	16
50	50	30	20
63	63	38	25
80	80	48	32
100	100	60	40

## HSK-E

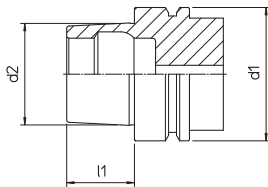

HSK-E	d1	d2	l1
32	32	24	16
40	40	30	20
50	50	38	25
63	63	48	32
-	-	-	-

## HSK-F

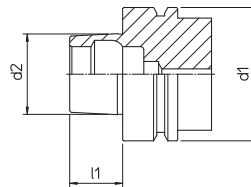

HSK-F	d1	d2	l1
-	-	-	-
-	-	-	-
50	50	30	20
63	63	38	25
80	80	48	32

## HSK-A HSK-E

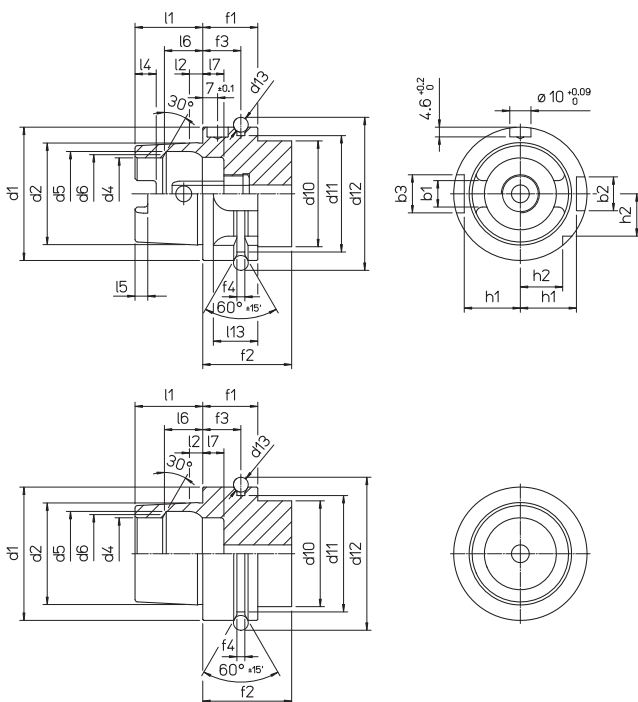

HSK	32	40	50	63	80	100
b1 $\pm 0.04$	7.05	8.05	10.54	12.54	16.04	20.02
b2 H10	7	9	12	16	18	20
b3 H10	9	11	14	18	20	22
d1 h10	32	40	50	63	80	100
d2	24.007	30.007	38.009	48.010	60.012	75.013
d4 H10	17	21	26	34	42	53
d5 H11	20.5	25.5	32	40	50	63
d6	19	23	29	37	46	58
d10 max.	26	34	42	53	68	88
d11 $0_{-0.1}$	26.5	34.8	43	55	70	92
d12 $0_{-0.1}$	37	45	59.3	72.3	88.8	109.75
d13	4		7			
f1 $0_{-0.1}$	20		26		29	
f2 min.	35		42		45	
f3 $\pm 0.1$	16		18		20	
f4 $0_{+0.15}$	2		3.75			
h1 $0_{-0.2}$	13	17	21	26.5	34	44
h2 $0_{-0.3}$	9.5	12	15.5	20	25	31.5
l1 $0_{-0.2}$	16	20	25	32	40	50
l2	3.2	4	5	6.3	8	10
l4 $0_{+0.2}$	5	6	7.5	10	12	15
l5 $0_{+0.2}$	3	3.5	4.5	6	8	10
l6 JS10	8.92	11.42	14.13	18.13	22.85	28.56
l7 $0_{-0.1}$	8		10	10	12.5	12.5
l13	12		19	21	22	24

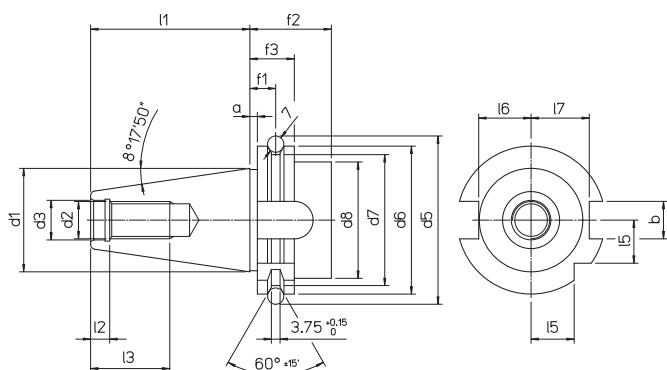

**DIN 69871 A**  
**( ISO 7388-1 )**

ISO	30	40	45	50	60
a ±0.1	3.2				
b $^{+0.5}_0$	16.1		19.3	25.7	
d1	31.75	44.45	57.15	69.85	107,95
d2 6H	M12	M16	M20	M24	M30
d3 H7	13	17	21	25	32
d5 ±0.05	59.3	72.3	91.35	107.25	164,75
d6 $^0_{-0.1}$	50	63.55	82.55	97.50	155
d7 $^0_{-0.5}$	44.3	56.25	75.25	91.25	147,70
d8 max.	45	50	63	80	130
f1 ±0.1	11.1				
f2 min.	35				38
f3 $^0_{-0.1}$	19.1				
l1 $^0_{-0.3}$	47.8	68.4	82.7	101.75	161,90
l2 $^{+0.5}_0$	5.5	8.2	10	11.5	14
l3 min.	24	32	40	47	59
l5 $^0_{-0.3}$	15	18.5	24	30	49
l6 $^0_{-0.3}$	16.4	22.8	29.1	35.5	54,5
l7 $^0_{-0.3}$	19	25	31.3	37.7	59,3

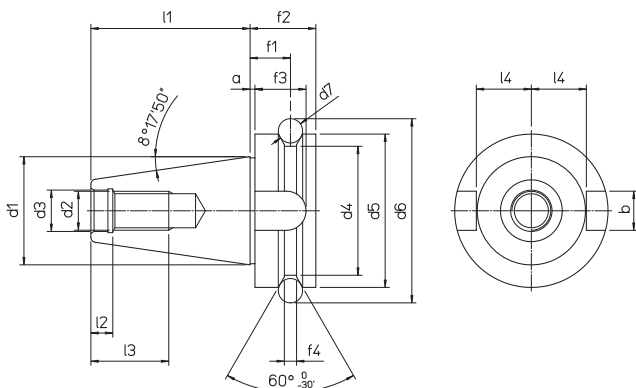
**MAS 403 BT A**

ISO	30	35	40	45	50	60
a ±0.4	2		3			
b $^{+0.2}_0$	16.1		19.3	25.7	25,7	
d1	31.75	38.10	44.45	57.15	69.85	107,95
d2 6H	M 12		M 16	M 20	M 24	M30
d3 H8	12.5		17	21	25	31
d4 $^0_{-0.5}$	38	43	53	73	85	135
d5 h8	46	53	63	85	100	155
d6 ±0.05	56.03	65.68	75.56	100.09	118.89	180,22
d7	8	10		12	15	20
f1 ±0.1	13.6	14.6	16.6	21.2	23.2	28,2
f2	22	24	27	33	38	48
f3 min.	17	20	21	26	31	34
f4	4	5		6	7	11
l1 ±0.2	48.4	56.4	65.4	82.8	101.8	161,8
l2 $^{+0.5}_0$	7		9	11	13	16
l3 min.	24		30	36	45	56
l4 $^0_{-0.3}$	16.3	19.6	22.6	29.1	35.4	60,1

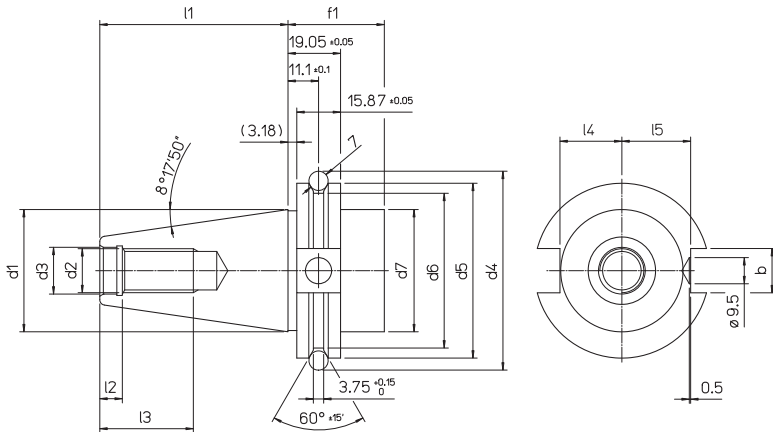

ISO	40	45	50
b $\begin{smallmatrix} +0.2 \\ 0 \end{smallmatrix}$	16.1	19.3	25.7
d1 6H	44.45	57.15	69.85
d2	M 16	M 20	M 24
d3 H7	17	21	25
d4 $\pm 0.05$	72.3	91.35	108.25
d5 $\begin{smallmatrix} 0 \\ -0.1 \end{smallmatrix}$	63.55	82.55	98.5
d6 $\begin{smallmatrix} 0 \\ -0.5 \end{smallmatrix}$	56.25	75.25	91.25
d7 $\pm 0.15$	44.45	57.15	69.95
f1 min	35		38
l1 $\begin{smallmatrix} 0 \\ -0.3 \end{smallmatrix}$	68.4	82.7	101.75
l2 $\begin{smallmatrix} +0.5 \\ 0 \end{smallmatrix}$	8.2	10	11.5
l3 min.	32	40	47
l4 $\begin{smallmatrix} 0 \\ -0.3 \end{smallmatrix}$	22.8	29.10	35.50
l5 $\begin{smallmatrix} 0 \\ -0.3 \end{smallmatrix}$	25	31.3	37.7

## DIN 2080

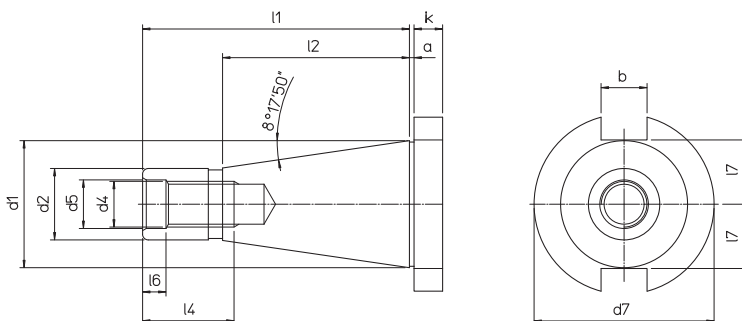

ISO	30	40	45	50
a $\pm 0.2$	1.6		3.2	
b H12	16.1		19.3	25.7
d1	31.75	44.45	57.15	69.85
d2 a10	17.4	25.3	32.4	39.6
d4 $\pm 0.05$	M 12	M 16	M 20	M 24
d5	13	17	21	26
d7 $\begin{smallmatrix} 0 \\ -0.4 \end{smallmatrix}$	50	63	80	97.5
k $\pm 0.15$	8	10	12	12
l1	68.4	93.4	106.8	126.8
l2	48.4	65.4	82.8	101.8
l4	24	32	40	47
l6 $\begin{smallmatrix} +0.5 \\ 0 \end{smallmatrix}$	5.5	8.2	10	11.5
l7 max.	16.2	22.5	29	35.3

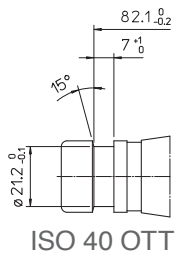

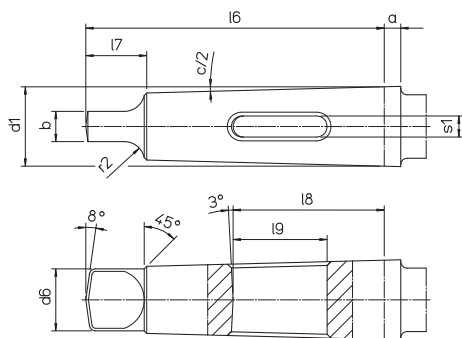
**DIN 228/B DIN 1806**

MORSE	4	5
a	6.5	
b H13	11.9	15.9
c/2	1°29'15"	1°30'26"
d1	31.267	44.399
d6 max.	24.5	35.7
l6 <sup>0</sup> <sub>-1</sub>	117.5	149.5
l7 max.	24	29
l8	59.5	64
l9	37	42
r2	8	10
s1	8.3	12.4

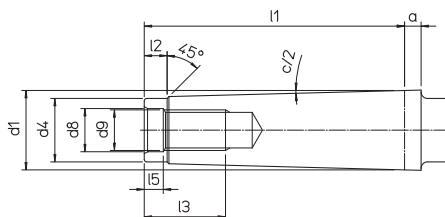
**DIN 228/A**

MORSE	4	4 SIP
a	6.5	
b d9	32	
c/2	1°29'15"	
d1	31.267	
d4 max.	25	
d8	17	
d9	M 16	M 14
l1 max.	102.5	
l2	9	
l3	32	
l5 <sup>+0.5</sup> <sub>0</sub>	8.2	
l6	15	
l7	23	

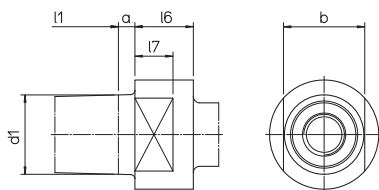
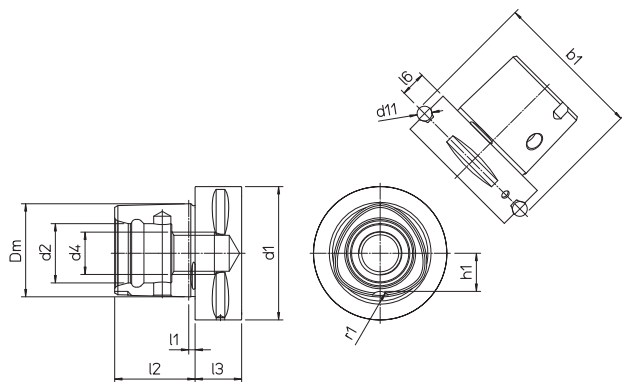
**DIN 2207**

**ISO 26623-1**

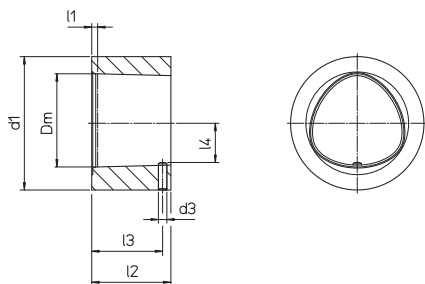
PSC	32	40	50	63	80	100
b1 ±0.1	39	46	59.3	70.7	86	110
Dm	22	28	35	44	55	72
d1 ±0.1	32	40	50	63	80	100
d2 <sup>+0.1</sup> <sub>-0.05</sub>	15	18	21	28	32	43
d4	M12x1.5	M14x1.5	M16x1.5	M20x2		M24x2
d11	5		7			10
l1	2.5		3			
l2 ±0.1	19	24	30	38	48	60
l3 min	15	20		22	30	36
l6 ±0.15	6	8	10	12		16
h1 ±0.1	9	11	14	18	22.2	29
r1 ±0.3	4	4	5	6	7	8

**ISO 26623-2**

PSC	32	40	50	63	80	100
Dm	22	28	35	44	55	72
d1 min	32	40	50	63	80	100
d3	2	2.5	3	4	5	6
l1	2.3	2.3	2.8	2.8	2.8	2.8
l2 ±0.1	18.4	23.4	29.4	37.4	47.4	59.4
l3 ±0.2	16.5	21	26	33.5	43	52.5
l4	9.4±0.1	11.5±0.2	14.5±0.2	18.5±0.2	22.8±0.2	29.6

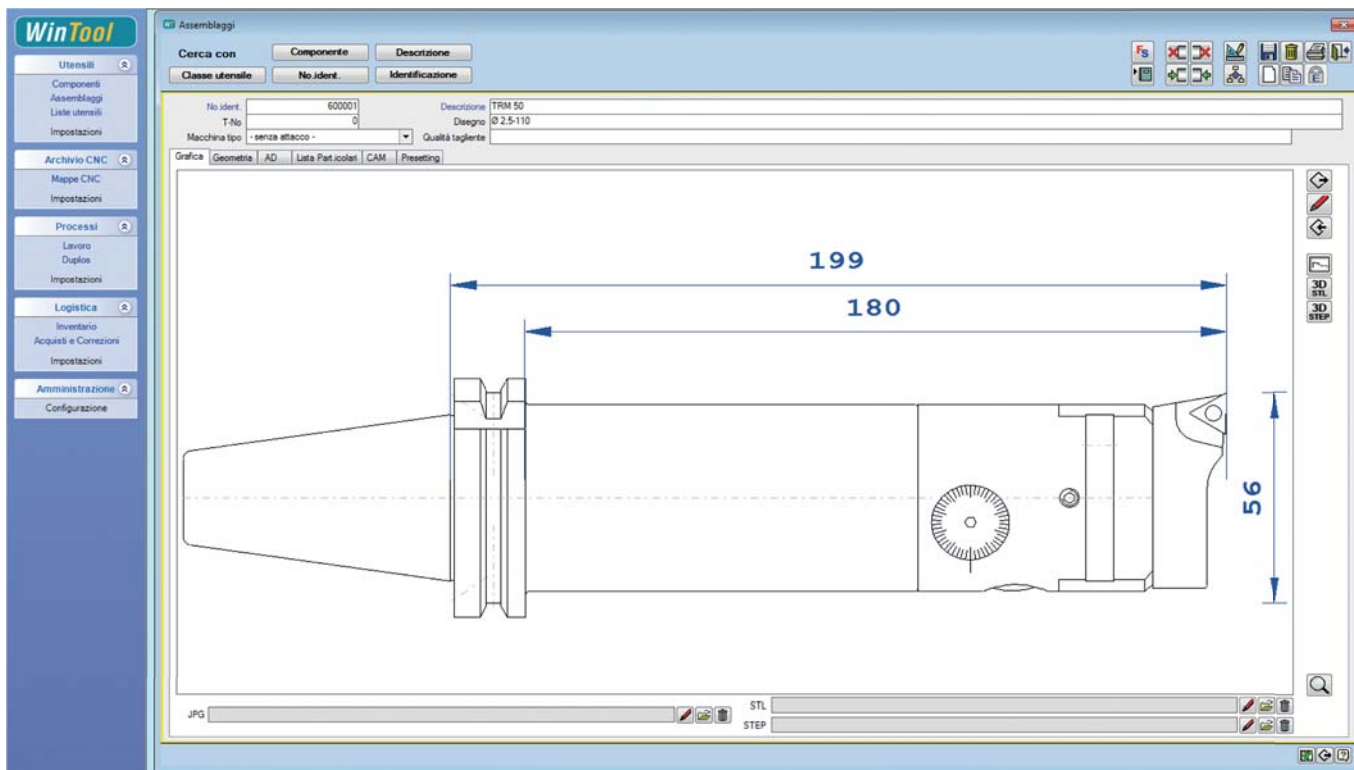
Generatore grafico che permette di comporre in breve tempo utensili completi con elementi del MODULHARD'ANDREA, indicando le dimensioni, il peso e la lista dei componenti.



**Scheda Utensile**

TRM 50      600001      Diametro parte pezzo 56,00  
 Ø 2,5-110

Descrizione / Tipo	Design / Item No / Product Code / Storage Location	Peso
1	DIN69871-AD+B40 FC MHD50.120	MHD 50
		41 8.50.01.040.28F
1	TRM 50	Ø 2,5-110
		45.50.050.0050.0
1	SFTP 50	TPGX 1103 . . L
		47.050.05.50.001
1	TPGX 110300L-10	DC 100T
		TPGX 110300L C10T
		<b>2,780</b>

## U-TRONIC pag.100

### SLITTA SINGOLA

UT 3-360 S  
Ø max 800

UT 5-500 S  
Ø max 1000

UT 5-630 S  
Ø max 1250

UT 5-800 S  
Ø max 1400

UT 8-800 S  
Ø max 1600

UT 8-1000 S  
Ø max 2000

UT 8-1250 S  
Ø max 2700

UT 8-1600 S  
Ø max 3200

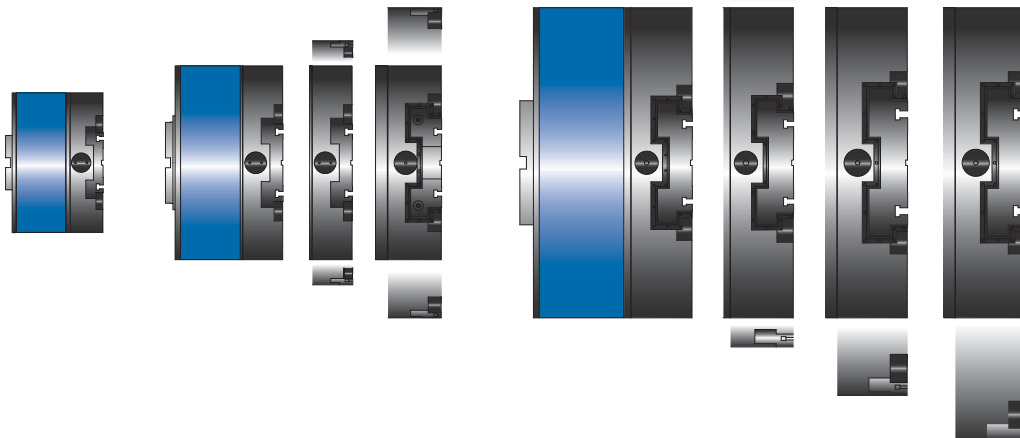

### RIDUTTORE

UT 3-360 S+R  
Ø max 800

UT 5-500 S+R  
Ø max 1000

UT 5-630 S+R  
Ø max 1250

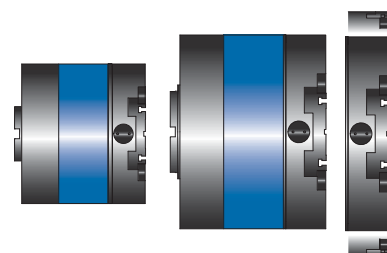

### UT-Speciali

**U-TRONIC** teste a CN di medie e grandi dimensioni, applicabili su alesatrici, centri di lavoro e macchine speciali. Lo spostamento della slitta è gestito da un servomotore integrato e direttamente collegato al CN e l'applicazione prevede una flangia di interfaccia che può essere realizzata in versione manuale, automatica, prolungata ed angolare. Oltre alla gamma standard, è disponibile la versione con riduttore integrato e, a richiesta le versioni speciali con foro, fino a Ø 1600 mm, a due slitte, con contrappesi per l'autobilanciamento e Synchro.®



Prolungate

## TA-CENTER pag.110

TA-C 80  
Ø max 160

TA-C 100  
Ø max 200

TA-C 160  
Ø max 320

TA-C 125  
Ø max 250

TA-C 200  
Ø max 400

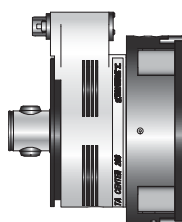
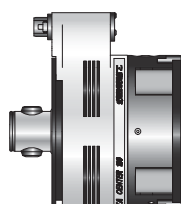

**TA-CENTER** teste dedicate a macchine con cambio utensile automatico e applicabili su ogni centro di lavoro. Lo spostamento della slitta portautensile è gestito da un gruppo di motorizzazione U-DRIVE esterno e fissato al mandrino macchina.

## TA-TRONIC pag.118

TA-T 100  
Ø max 200

TA-T 160  
Ø max 320

TA-T 125  
Ø max 250

TA-T 200  
Ø max 400

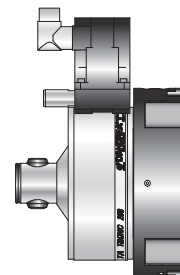
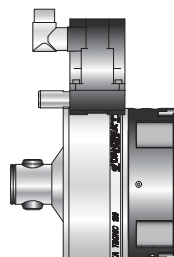
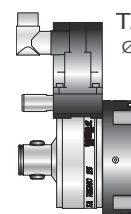
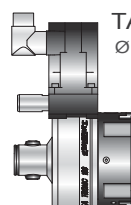

**TA-TRONIC** Teste progettate per essere applicate manualmente su piccole alesatrici, centri di lavoro e macchine speciali. Il motore integrato si collega al CN e gestisce lo spostamento della slitta portautensile. Il corpo fisso viene sostenuto da una flangia o, per operazioni poco gravose, da un semplice perno antirotazione.



# - RAGGIATURA - FILETTATURA

## HOLE

UT 5-500 HOLE

Ø max 1000

UT 5-630 HOLE

Ø max 1200

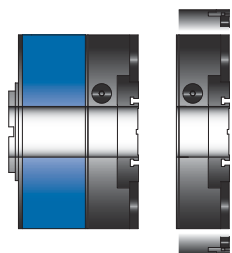

## DOPPIA SLITTA

UT 5-500 D

Ø max 1000

UT 5-630 D

Ø max 1200

UT 5-800 D

Ø max 1400

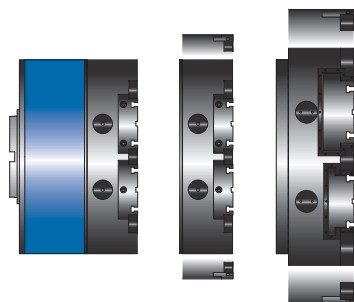

## ALTA VELOCITA'

UT 3-360BH

Ø max 600

UT 5-500 BH

Ø max 900

UT 5-630 BH

Ø max 1100

UT 8-800 BH

Ø max 1400

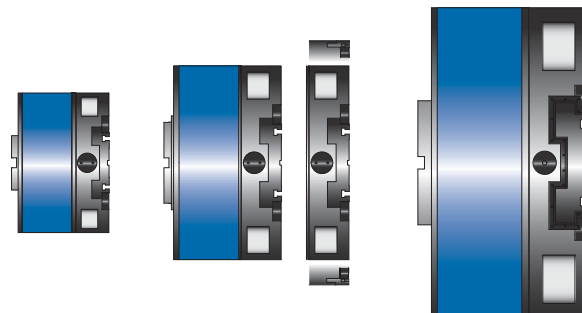

Angolari



Alta Velocità



Doppia Slitta

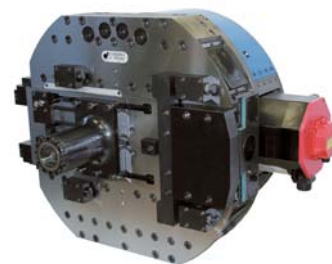

Synchro<sup>®</sup>

## U-COMAX pag.124

CMX 125

Ø max 200

CMX 160

Ø max 250

CMX 200

Ø max 320

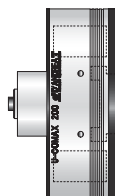
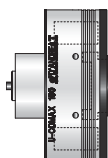

AR 125

Ø max 320

AR 160

Ø max 400

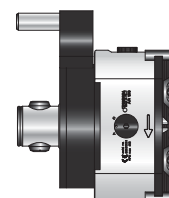

**U-COMAX** teste a comando assiale destinate all'impiego su macchine transfer o unità speciali. Lo spostamento della slitta è gestito da un gruppo di motorizzazione U-DRIVE montato posteriormente all'unità mandrino e gestito dal CN. Disponibile l'opzione **Synchro<sup>®</sup>**.

**AUTORADIAL** teste automatiche a sfacciare, applicabili su centri di lavoro e macchine a CN senza bisogno di alcuna interfaccia elettronica od asservimento. Eseguono automaticamente un ciclo di lavoro senza mai arrestare la rotazione del mandrino. Particolarmente indicate per l'esecuzione di sedi per anelli elastici e spirali fonografiche.

# U-TRONIC

**U-TRONIC** teste a CN di medie e grandi dimensioni, applicabili su alesatrici, centri di lavoro e macchine speciali. Lo spostamento della slitta è gestito da un servomotore integrato e direttamente collegato al CN e l'applicazione prevede una flangia di interfaccia che può essere realizzata in versione manuale, automatica, prolungata ed angolare. Oltre alla gamma standard, è disponibile la versione con riduttore integrato e, a richiesta le versioni speciali con foro, fino a  $\varnothing$  1600 mm, a due slitte, con contrappesi per l'autobilanciamento e **Synchro**.<sup>®</sup>

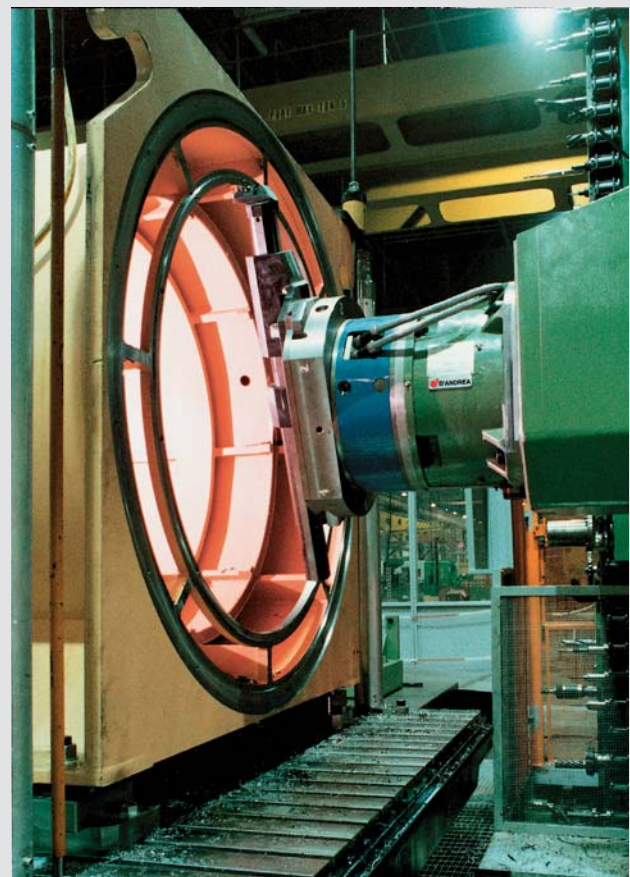
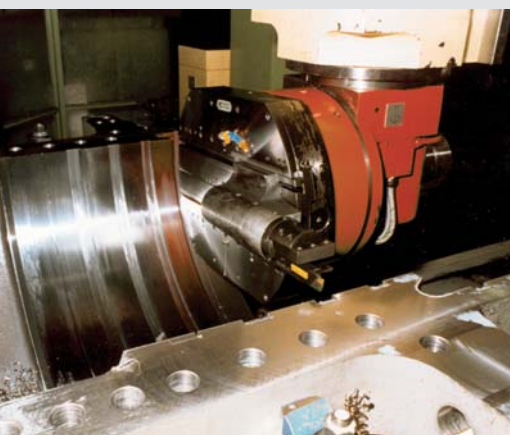
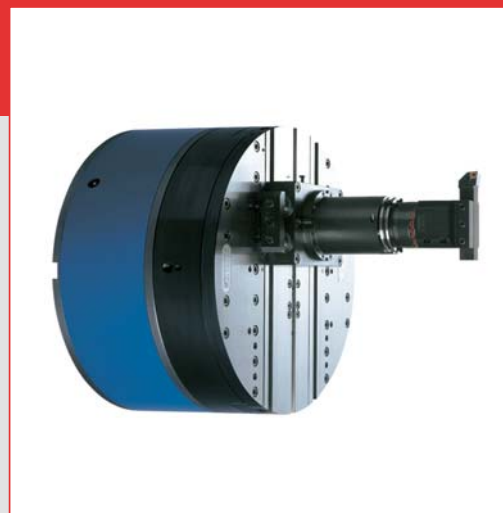

## COMPONENTI

1. Corpo fisso
2. Corpo rotante
3. Slitta portautensili
4. Cinematismo
5. Cuscinetti
6. Passaggio refrigerante
7. Servomotore
8. Microinterruttori di finecorsa
9. Flangia
10. Encoder a richiesta

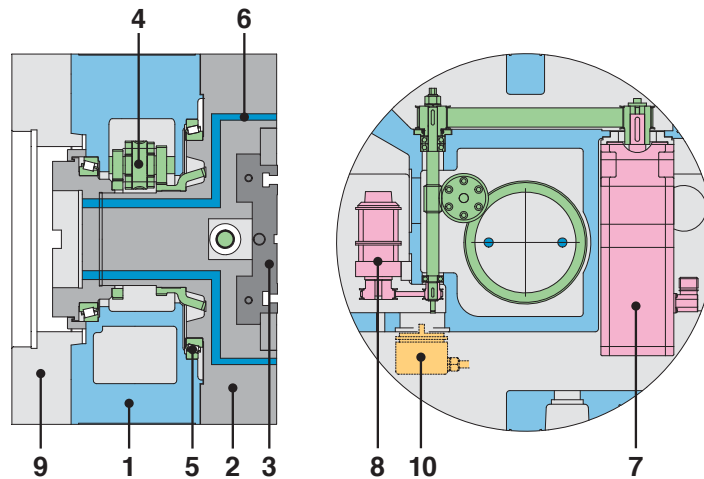

## COMANDO

Il comando delle teste U-TRONIC avviene tramite il collegamento diretto all'asse "U" del controllo numerico della macchina utensile e permette di eseguire ogni tipo di operazione di tornitura, alesature, sfacciate interne, esterne, filettature, raggiature e operazioni sferiche.

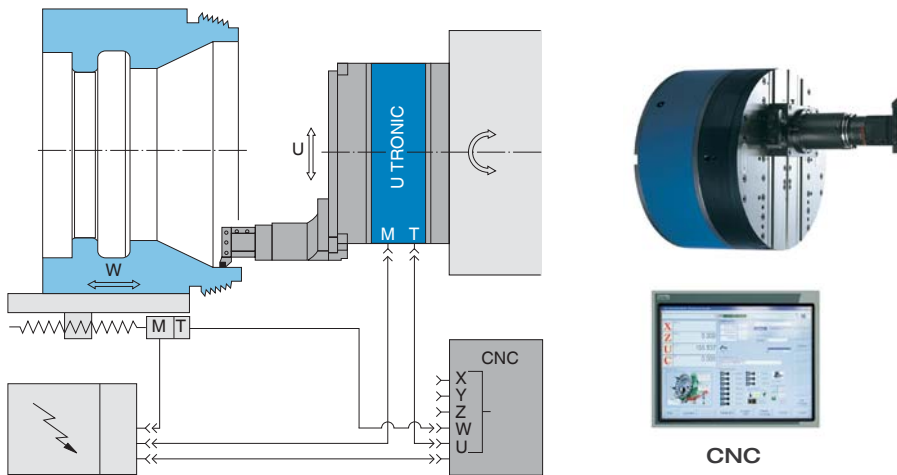

## PREDISPOSIZIONI

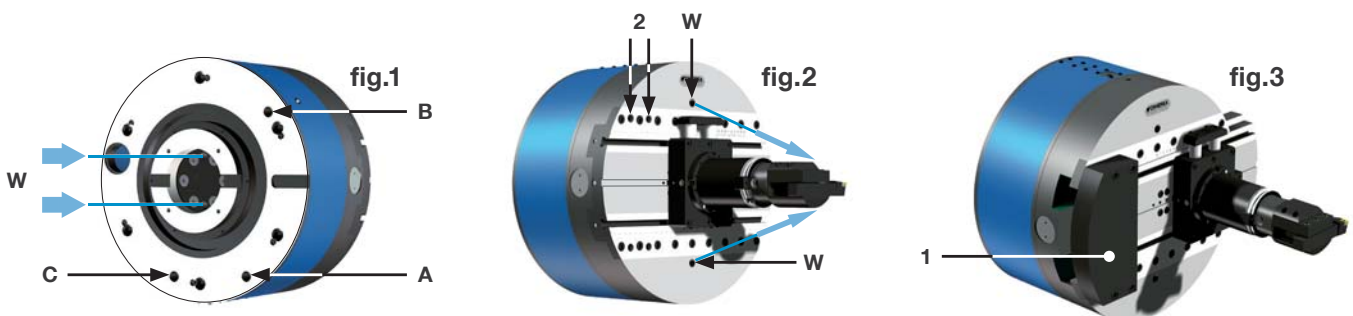

### A-Pressurizzazione interna fig.1

Per evitare che liquido e polvere entrino nella zona del motore, trasduttore e finecorsa, è previsto un foro  $\varnothing 8,5$  (A) per pressurizzare l'interno del corpo fisso con l'ingresso dell'aria a 0,5-1 BAR.

### B-Ingrassatore automatico fig.1

Sulla testa è previsto un foro  $\varnothing 8,5$  (B) per permettere l'inserimento automatico del grasso all'interno della U-TRONIC.

### C-Lubrificazione nebulizzata fig.1

Per lubrificare automaticamente le guide di scorrimento e la vite madre per il trascinamento della slitta portautensile posti nel corpo rotante della U-TRONIC, a richiesta è possibile predisporre la testa per immettere nel foro  $\varnothing 8,5$  (C) un flusso costante minimo di 10 g/h d'olio nebulizzato ad una pressione di 0,5-1 BAR.

### Adduzione liquido refrigerante fig.1-2

All'interno del corpo rotante della U-TRONIC sono previste delle canalizzazioni (W) che permettono il passaggio del liquido refrigerante dal mandrino della macchina sino a due fori filettati posti a fianco della slitta (W). Su tali fori è possibile avvitare dei condotti flessibili e portare il liquido refrigerante direttamente all'utensile. Pressione **Max BAR 40**.

### Bilanciatura fig.3

Per migliorare le condizioni di lavoro e bilanciare la posizione dell'utensile quando risulta spostato rispetto all'asse della U-TRONIC, è possibile applicare dei contrappesi (1) utilizzando i fori filettati (2) posti sul corpo rotante.



Le U-TRONIC si applicano manualmente o automaticamente mediante una flangia per il fissaggio alla macchina utensile e un piatto per la rotazione del corpo rotante.

Si applicano manualmente utilizzando una flangia per il fissaggio con attacco rapido camlock, o automaticamente con sistemi palettizzati e appositi connettori.



I seguenti layout riportano i dati di base per la costruzione delle flange con attacco rapido camlock. Le U-TRONIC UT 8-800 S e UT 8-1000 S non prevedono il fissaggio con attacco rapido camlock.

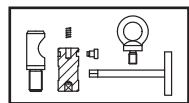

### 394200136000

- n°6 100051080012
- n°1 100541100100    n°6 101601020600    n°6 101601010600
- n°1 101500701200    n°6 100551060023    n°6 200100150817

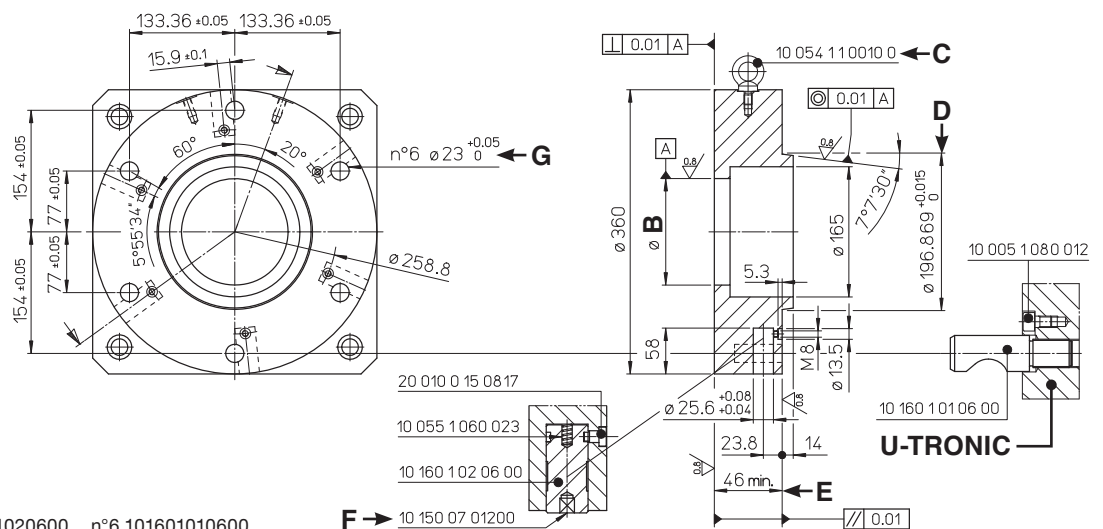

### U-TRONIC 5-500 / 5-630 / 5-800 S

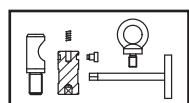

### 394200150000

- n°6 100051080015
- n°1 100541100160    n°6 101601020800    n°6 101601010600
- n°1 101500701400    n°6 100551060023    n°6 200100150818

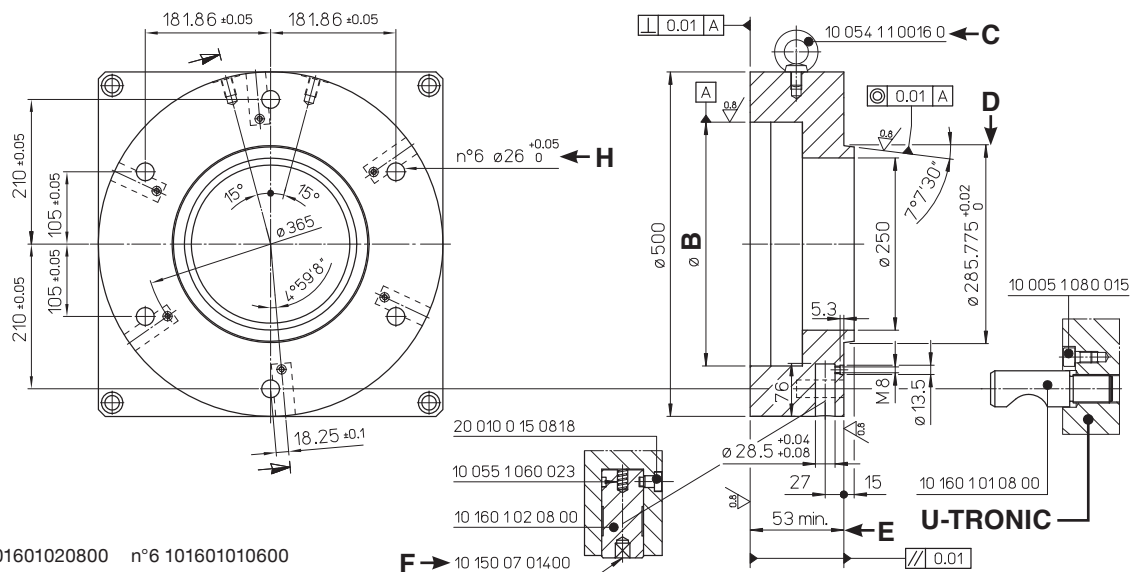

**B** Centraggio mandrino **C** Golfare **D** Controllare con calibro **E** Quota da controllare in funzione della sporgenza mandrino  
**F** Chiave di manovra **G** Fori prof. min. 46 **H** Fori prof. min. 53

## CAPACITÀ DI ASPORTAZIONE

Le asportazioni sono indicative per condizioni di lavoro normali su acciai con durezza 160-200 HB, ( $K_s$  medio = 2000 N/mm<sup>2</sup>)  $V_t$  consigliata 120/160 m/min. I valori ottimali ed i tempi di lavoro dovranno essere determinati con delle prove.

### U-TRONIC 3-360 S

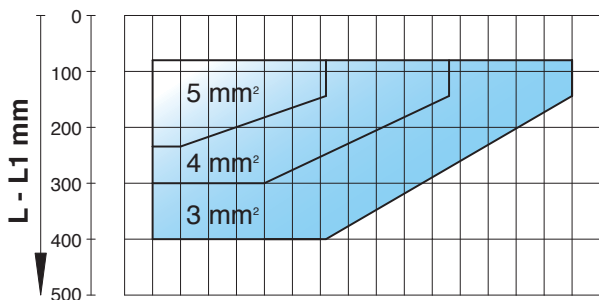
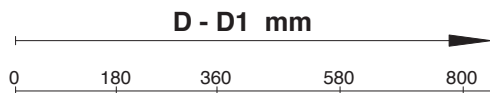
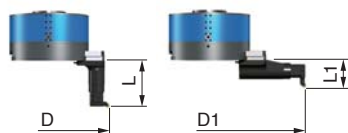

### U-TRONIC 5-500 S 5-630 S 5-800 S

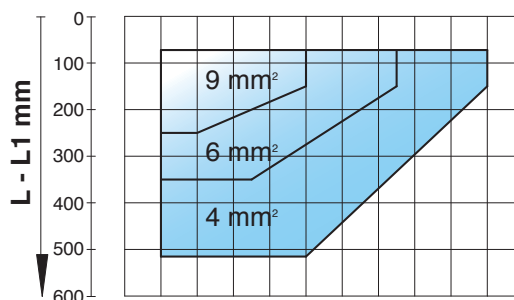
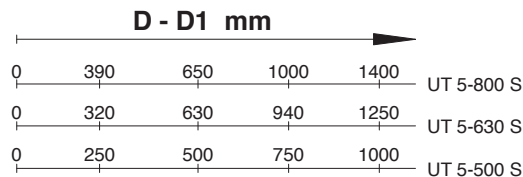
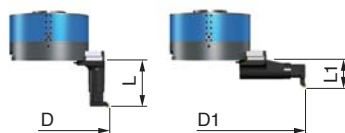

### U-TRONIC 8-800 S 8-1000 S

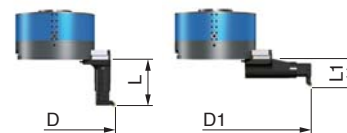
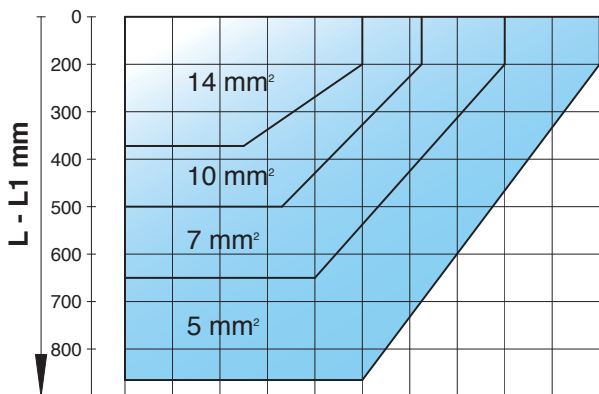
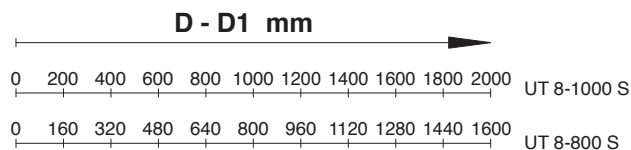

Per un buon impiego della testa TA-CENTER e per salvaguardarne l'integrità è consigliato seguire il grafico sottostante che indica il numero di giri massimo in funzione della corsa della slitta.

## MAX VELOCITÀ DI ROTAZIONE

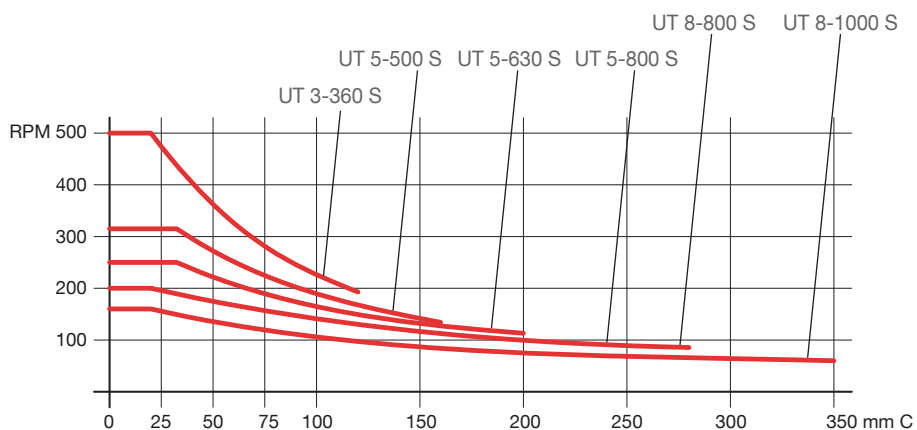





UT 3-360 S

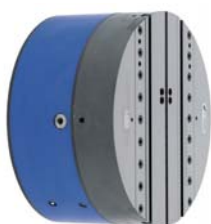

UT 5-500 S

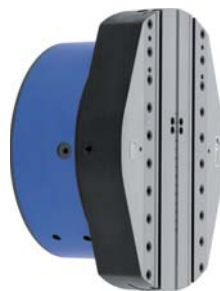

UT 5-630 S

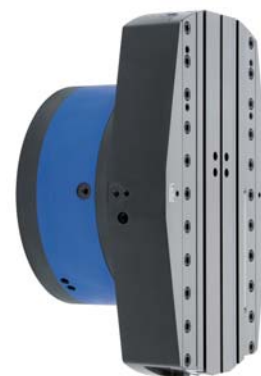

UT 5-800 S

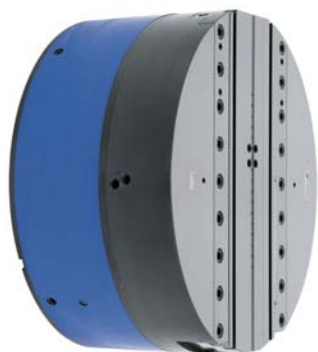

UT 8-800 S

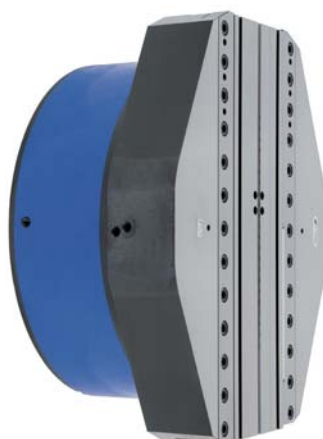

UT 8-1000 S

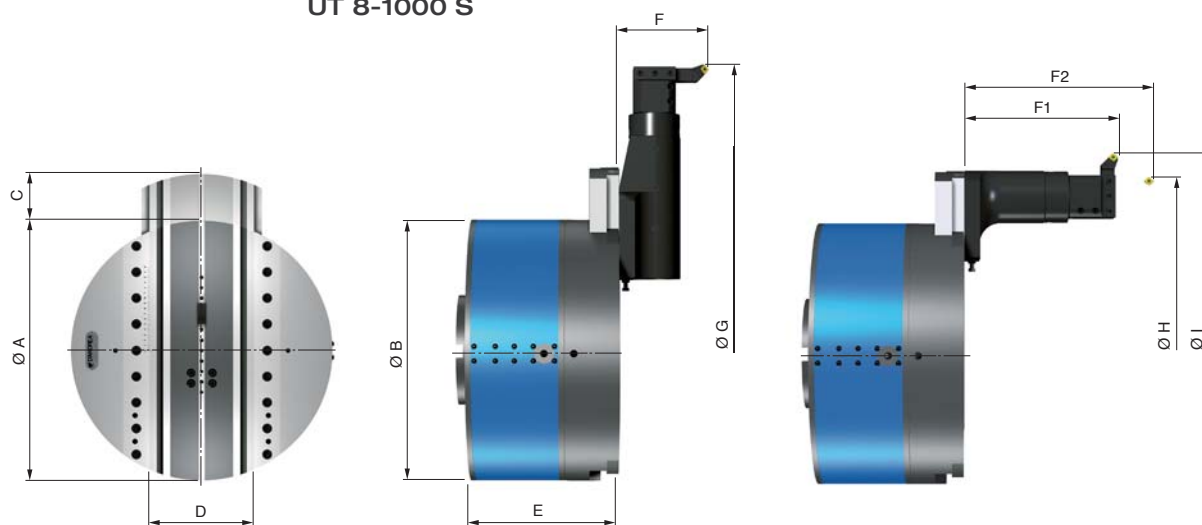

DATI TECNICI		UT 3-360 S	UT 5-500 S	UT 5-630 S	UT 5-800 S	UT 8-800 S	UT 8-1000 S
Ø A	mm	360	500	630	800		1000
Ø B	mm	360	500		800		
C Corsa radiale	mm	120	160	200	250	280	350
D	mm	154.6	199.6		230	250	260
E	mm	235	278.5	282	370	410	415
Ø G x F	mm	800 x 140	1000 x 150	1250 x 150	1400 x 150	1600 x 160	2000 x 160
Ø H x F2	mm	400 x 400	560 x 540	700 x 540	830 x 540	850 x 860	1050 x 860
Ø I x F1	mm	670 x 240	850 x 295	1050 x 295	1300 x 295	1250 x 370	1600 x 370
Max. mm/min	mm/min	1 ÷ 400				1 ÷ 500	
Max. $\omega$ /min	RPM	500	315	250	200		160
Peso	Kg	130	230	310	530	1000	1200
Forza radiale	daN	400	500		1000		
Momento torcente	daNm	400	800		1000		
Precisione in alesatura		H7					
Max asportazione	mm <sup>2</sup> C40	5	9		14		
Rapido	mm/min	400				500	
Rugosità	Ra	0,8 ~ 1,2					

# U-TRONIC S+R

Le U-TRONIC S+R a differenza della versione standard U-TRONIC S, hanno al loro interno un riduttore con rapporto di riduzione 1:4 per permettere di aumentarne la coppia di lavoro e quindi l'asportazione. Risultano quindi particolarmente adatte ad applicazioni con elettro-mandri ad alta potenza/velocità che presentano curve di coppia limitate a bassi giri. Sono costruite in 3 modelli da  $\varnothing 360$  a  $\varnothing 630$  mm tutte con passaggio interno del liquido refrigerante.

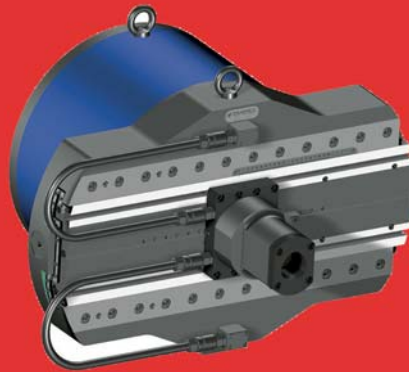

U-TRONIC S+R

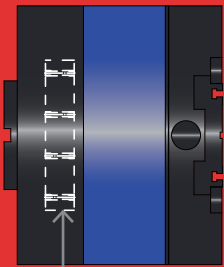

GEARBOX

GEARBOX		UT3-360 S+R	UT5-500 S+R	UT5-630 S+R
Rapporto di trasmissione		1:4		
Coppia nominale in uscita	Nm	4000	6000	
Coppia max in uscita	Nm	5000	8000	
Max numero di giri	RPM	2000	1000	1260
Velocità di uscita ammessa	RPM	500	315	250

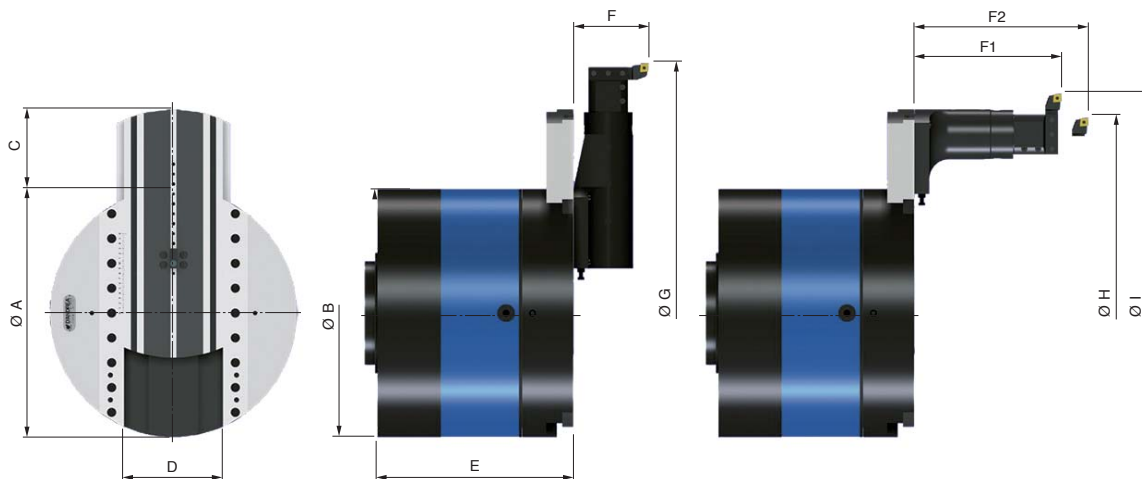
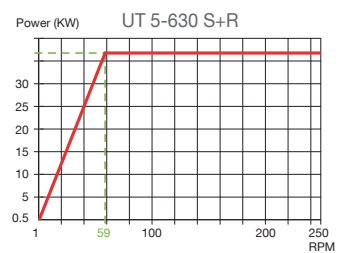
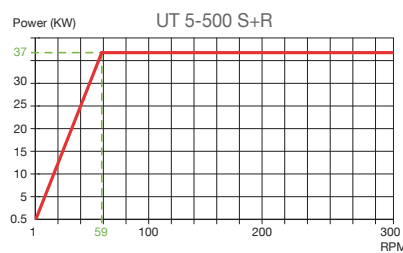
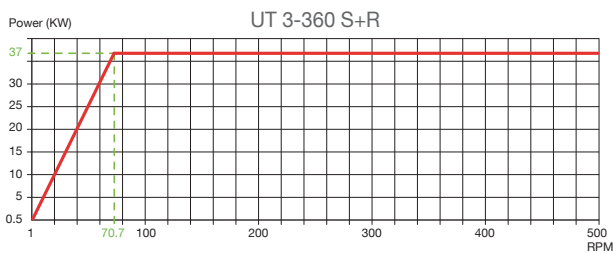

DATI TECNICI		UT 3-360 S+R	UT 5-500 S+R	UT 5-630 S+R
$\varnothing A$	mm	360	500	630
$\varnothing B$	mm	360	500	500
C Corsa radiale	mm	120	160	200
D	mm	154.6	199.6	
E	mm	335	396.5	400
$\varnothing G \times F$	mm	800 x 140	1000 x 150	1250 x 150
$\varnothing H \times F2$	mm	400 x 400	560 x 540	700 x 540
$\varnothing I \times F1$	mm	670 x 240	850 x 295	1050 x 295
Max. mm/min	mm/min	1 ÷ 400		
Peso	Kg	150	370	450
Forza radiale	N	4000	5000	
Precisione in alesatura		H7		
Max asportazione	mm <sup>2</sup> C40	5	9	

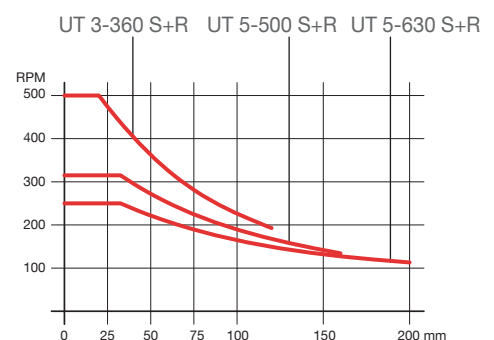

UT 3-360 / 5-500 / 5-630 / 5-800 / 8-800 / 8-1000 S  
 UT 3-360 / 5-500 / 5-630 S + R

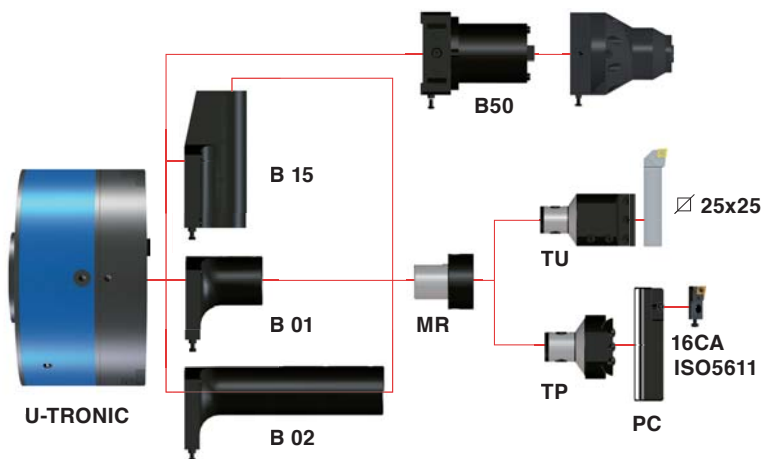

1 B 01  
 1 B 02  
 1 B 15  
 1 MR  
 1 TU

### K03

REF.	CODE
KIT K03 UT 3-360 S	501703259300
KIT K03 UT 5-500 / 5-630 / 5-800 S	501705009300
KIT K03 UT 8-800 / 8-1000 S	501708009300

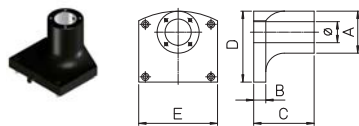

U-TRONIC	REF.	CODE	ØH7	A	B	C	D	E	kg.	B01/B02
UT 3-360 S	B01	443005001150	50	80	23	100	135	150	5.5	
	B02	443005002750	50	80	23	260	135	150	8.5	
UT 5-500 / 5-630 / 5-800 S	B01	443006301550	63	100	30	155	170	200	11	
	B02	443006303650	63	100	30	400	170	200	19	
UT 8-800 / 8-1000 S	B01	443008002300	80	130	30	230	200	250	25	
	B02	443008007200	80	130	30	720	250	250	60	

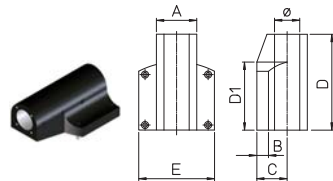

U-TRONIC	REF.	CODE	ØH7	A	B	C	D	D1	E	Kg.	B15
UT 3-360 S	B15	445005001900	50	80	23	60	190	135	150	3.7	
UT 5-500 / 5-630 / 5-800 S	B15	445006302500	63	100	30	70	270	170	200	7.5	
UT 8-800 / 8-1000 S	B15	445008003001	80	130	30	85	300	200	250	34	

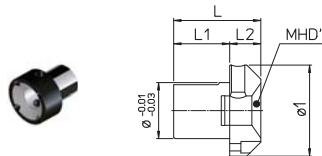

U-TRONIC	REF.	CODE	MHD'	ØH7	Ø1	L	L1	L2	Kg.	MR
UT 3-360 S	MR 50/80.80	450208001060	80	50	80	95	50	45	1.6	
UT 5-500 / 5-630 / 5-800 S	MR 63/98.80	450209801060	80	63	98	105	60	45	3	
UT 8-800 / 8-1000 S	MR 80/130.80	450213001240	80	80	130	125	80	45	6	
	MR 80/130.110	450213001340	110	80	130	185	80	105	9	

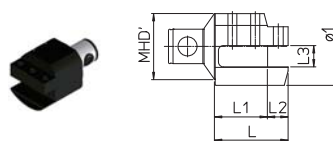

U-TRONIC	REF.	CODE	MHD'	Ø1	L	L1	L2	L3	Kg.	TU
UT 3-360 S	TU 80/95.25	460508025001	80	95	90	65	25	32	4	
UT 5-500 / 5-630 / 5-800 S	TU 80/95.25	460508025001	80	95	90	65	25	32	4	
UT 8-800 / 8-1000 S	TU 80/95.25	460508025001	80	95	90	65	25	32	4	
	TU 110/110.32	460511032001	110	130	110	78	32	32	11.2	

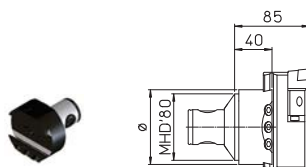

U-TRONIC	REF.	CODE	Ø	Kg.	TP
UT 3-360 S	TP 80/90.50	460408050001	90	2.3	
UT 5-500 / 5-630 / 5-800 S	TP 80/90.50	460408050001	90	2.3	
UT 8-800 / 8-1000 S	TP 80/125.50	460408050002	125	3.2	

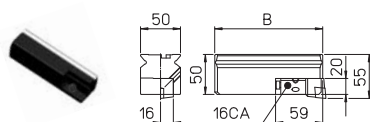

U-TRONIC	REF.	CODE	Ø	Kg.	PC
UT 3-360 S	PC 11.50	433050160950	95	1.3	
	PC 12.50	433050161350	135	2	
UT 5-500 / 5-630 / 5-800 S	PC 13.50	433050162000	200	3.2	
	PC 14.50	433050163000	300	5	



## UT 3-360 / 5-500 / 5-630 / 5-800 / 8-800 / 8-1000 S UT 3-360 / 5-500 / 5-630 S + R

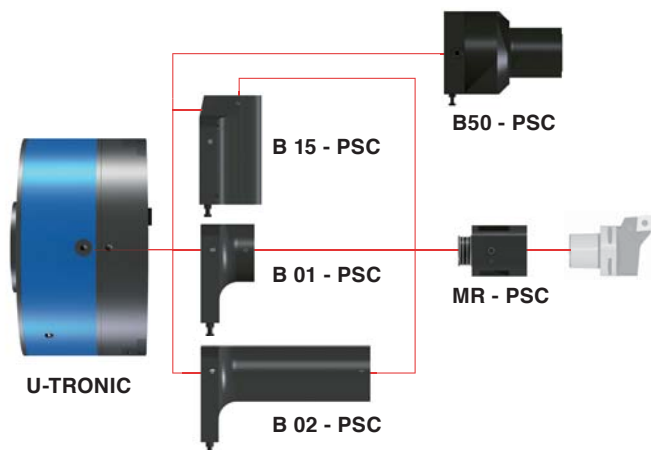

### K03 - PSC



1 B 01 - PSC  
1 B 02 - PSC  
1 B 15 - PSC  
1 MR - PSC

REF.	CODE
KIT K03 PSC 63 UT 3-360 S	501703259304
KIT K03 PSC 63 UT 5-500 / 5-630 / 5-800 S	501705009310
KIT K03 PSC 80 UT 5-500 / 5-630 / 5-800 S	501705009302
KIT K03 PSC 80 UT 8-800 / 8-1000 S	501708009301

### B01 / B02 - PSC

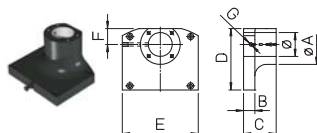

U-TRONIC	REF.	CODE	ØH7	A	B	C	D	E	F	G	kg.
UT 3-360 S	<b>B01 - PSC 63</b>	443005000310	63	105	23	31	137	150	42	G1/8'	3.5
	<b>B02 - PSC 63</b>	443005001610	63	105	23	161	137	150	42	G1/8'	10
UT 5-500 / 5-630 / 5-800 S	<b>B01 - PSC 63</b>	443006302002	63	105	30	86	162	200	42	G1/8'	11
	<b>B02 - PSC 63</b>	443006304452	63	105	30	331	162	200	42	G1/8'	20
UT 8-800 / 8-1000 S	<b>B01 - PSC 80</b>	443006302001	75	130	30	71	185	180	50	G1/8'	10.5
	<b>B02 - PSC 80</b>	443006304451	75	130	30	316	235	180	50	G1/8'	30

### B15 - PSC

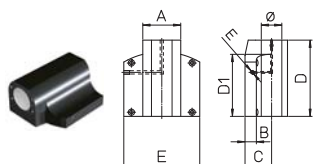

U-TRONIC	REF.	CODE	ØH7	A	B	C	D	D1	E	F	G	Kg.
UT 3-360 S	<b>B15 - PSC 63</b>	445005001210	63	100	23	60	121		150	42	G1/8'	8
UT 5-500 / 5-630 / 5-800 S	<b>B15 - PSC 63</b>	445006303152	63	100	30	70	201	170	200	42	G1/8'	6.5
	<b>B15 - PSC 80</b>	445006303911	75	130	39	85	262	200	180	50	G1/8'	27.5
UT 8-800 / 8-1000 S	<b>B15 - PSC 80</b>	445008003005	75	130	30		300	200	250	50	G1/4'	33

### MR - PSC

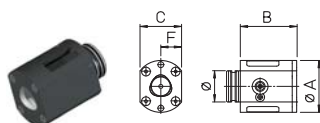

U-TRONIC	REF.	CODE	Øg6	A	B	C	F	Kg.
UT 3-360 S	<b>MR - PSC 63</b>	450206000630	63	105	114	84	42	6.5
UT 5-500 / 5-630 / 5-800 S	<b>MR - PSC 63</b>	450206000630	63	105	114	84	42	6.5
UT 5-500 / 5-630 / 5-800 S	<b>MR - PSC 80</b>	450208000800	75	130	129	100	50	11
UT 8-800 / 8-1000 S	<b>MR - PSC 80</b>	450208000800	75	130	129	100	50	11

## PORTAUTENSILI A CAMBIO AUTOMATICO B50 MHD' - PSC



fig.1



fig.1

U-TRONIC	REF.
UT 3-360 S	<b>B50 MHD' HSK - A63 -A100</b>
UT 5-500 / 5-630 / 5-800 S	<b>B50 MHD' DIN69871-A-B 50</b>
UT 8-800 / 8-1000 S	<b>B50 MHD' MAS BT50</b>

U-TRONIC	REF.
UT 3-360 S	<b>B50 PSC 63-80</b>
UT 5-500 / UT 5-630 / 5-800 S	<b>B50 PSC 63-80</b>
UT 8-800 / 8-1000 S	<b>B50 PSC 63-80</b>

A richiesta sono fornibili portautensili a cambio automatico dell'utensile B50, speciali e OLEODINAMICI (fig.1)

# U-TRONIC SYNCHRO

Il nuovo sistema brevettato **SYNCHRO** D'Andrea si riferisce all'applicazione su una testa del concetto di sincronizzazione tra gli assi. Il controllo dell'avanzamento della slitta portautensili si esegue sincronizzando il motore che permette la rotazione del mandrino macchina con il motore dedicato allo spostamento della slitta portautensile.

La sincronizzazione tra gli assi viene gestita dal controllo numerico della macchina. La soluzione consente di aumentare le prestazioni generali della testa, in particolare la velocità di avanzamento della slitta.

Synchro <sup>®</sup>

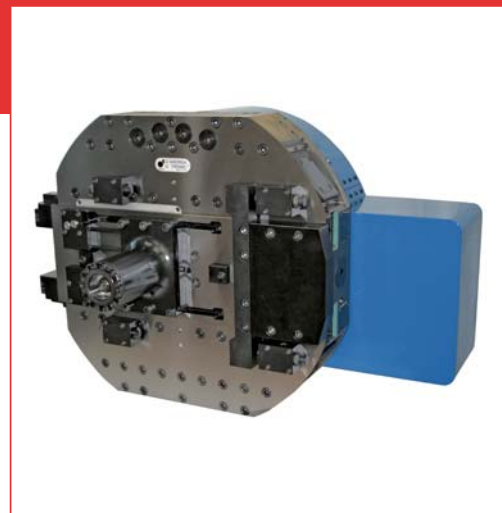

## SOLUZIONI SPECIALI



Prolungate



Doppia Slitta

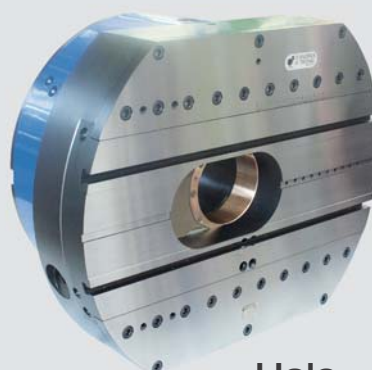

Hole



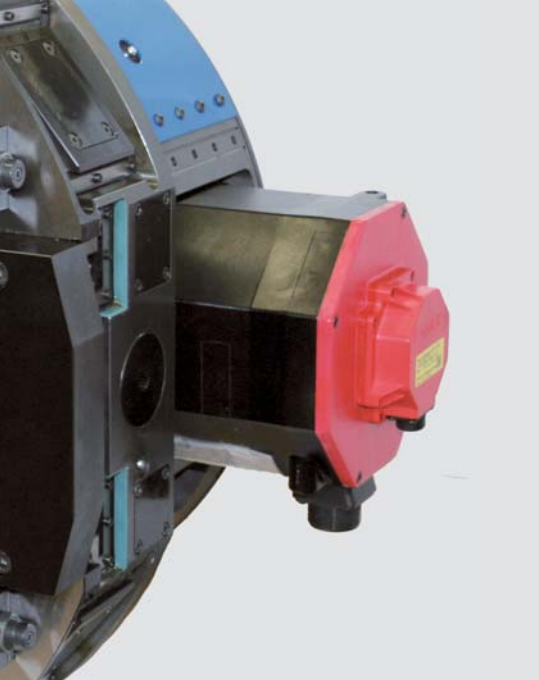

## APPLICAZIONE DEL SISTEMA SYNCHRO D'ANDREA SU TESTE U-TRONIC

Nella figura schematizzata la testa U-TRONIC, dotata del sistema **SYNCHRO** D'Andrea, ha il controllo dell'avanzamento slitta portautensili (2) tramite il motore (1).

Il motore (1) è montato sul corpo fisso della testa e trasmette il moto, tramite una coppia di ingranaggi e una vite a ricircolo, alla slitta

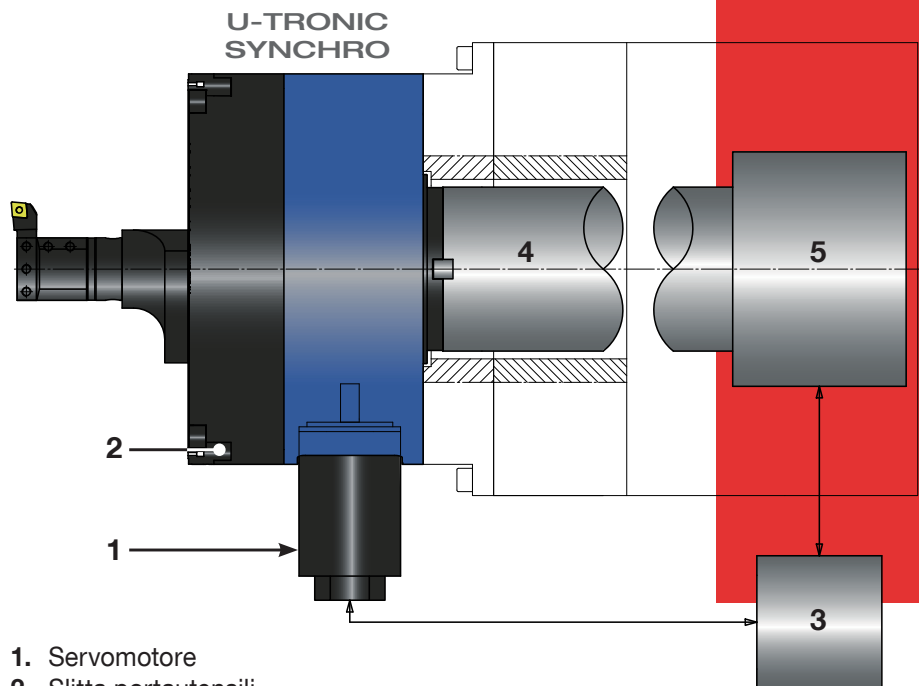

1. Servomotore
2. Slitta portautensili
3. Macchina utensile C.N.C.
4. Mandrino della macchina utensile
5. Servomotore mandrino della macchina utensile

portautensili (2) che si trova sul corpo rotante azionato dal mandrino macchina (4). Per comandare il movimento traslatorio della slitta (2) occorre sincronizzare la rotazione del motore (1) con il motore del mandrino macchina (5), e si ottiene facendo ruotare allo stesso numero di giri i due motori (condizione con slitta ferma).

La differenza tra la velocità di rotazione del motore (1) con il motore mandrino (5) genera lo spostamento radiale della slitta portautensili (2). La corretta sincronizzazione tra o due organi in rotazione si ottiene programmando adeguatamente il controllo numerico della macchina utensile.

Alta velocità

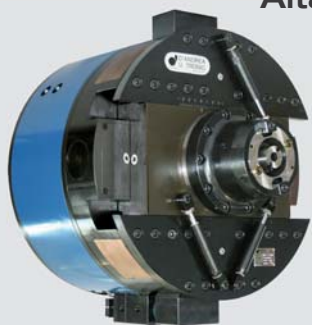

Alta velocità

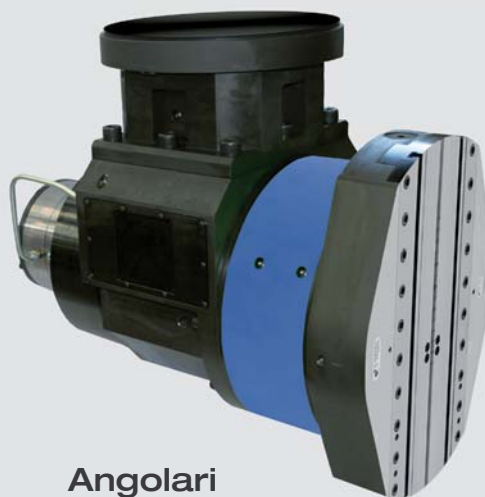

Angolari



# TA-CENTER

**TA-CENTER** teste dedicate a macchine con cambio utensile automatico  
e applicabili su ogni centro di lavoro.

Lo spostamento della slitta portautensile è gestito da un gruppo di motorizzazione  
U-DRIVE esterno e fissato al mandrino macchina.

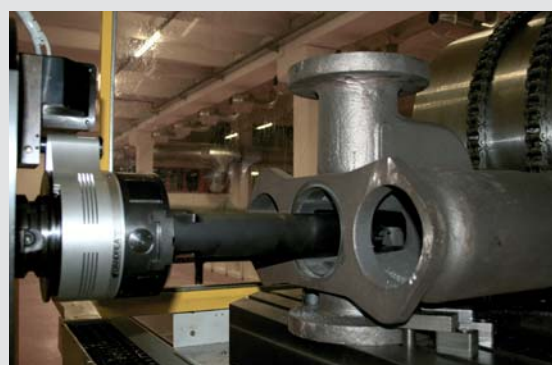

## COMPONENTI

1. Corpo fisso
2. Corpo rotante
3. Slitta portautensili
4. Cono intercambiabile
5. Contrappesi di equilibratura
6. Attacco MHD'
7. Ugelli di uscita del liquido lubro-refrigerante
8. Anello di orientamento
9. Perno di ritegno
10. Presa di moto 'A'
11. Dispositivo di rotazione manuale

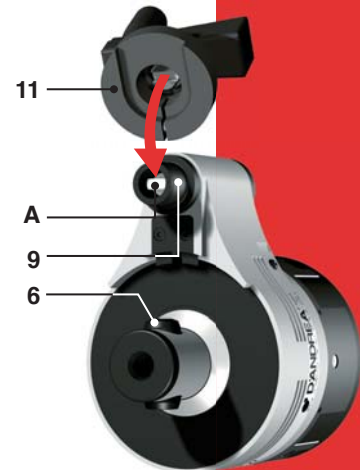
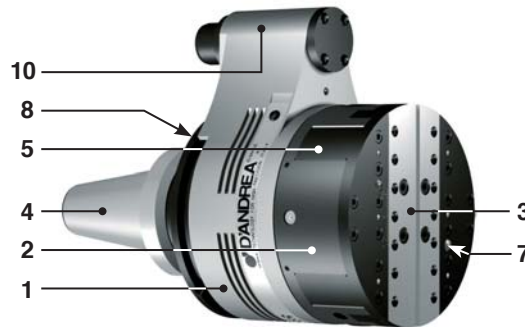

12. Corpo base
13. Servomotore
14. Gruppo meccanico per il collegamento alla presa di moto della TA-CENTER
15. Predisposizione attacco entrata aria per pulizia della presa di moto
16. Ingrassatore manuale
17. N°6 fori M5x8 da utilizzare per il fissaggio di un eventuale carter di protezione

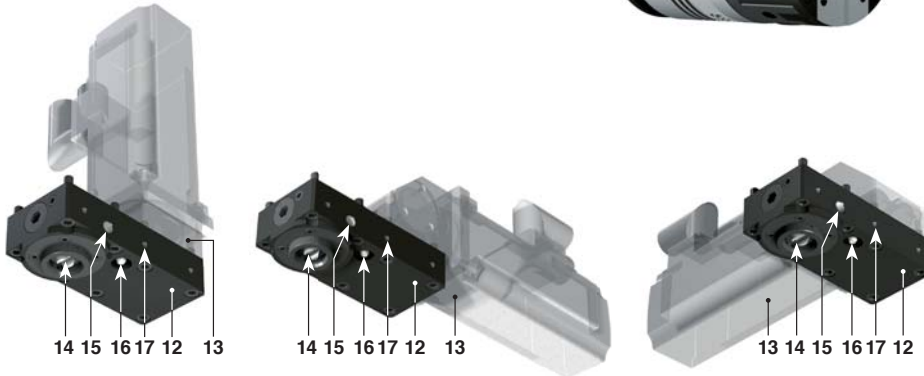

## COMANDO



Le teste per alesare e sfacciare TA-CENTER nascono per essere impiegate su macchine con cambio utensili automatico, dunque essenzialmente su tutti i centri di lavoro.

Il controllo dell'avanzamento, della slitta portautensili e della posizione utensile, anche durante la rotazione, è comandato da un gruppo di motorizzazione **U-DRIVE**. Questo gruppo viene gestito direttamente da un asse chiamato "U" del controllo numerico del centro di lavoro. Un centro di lavoro così predisposto permetterà di risolvere una serie di lavorazioni differenti come tornitura interna ed esterna, canalini, alesature coniche anche variabili, raggiature concave e convesse, filettature cilindriche e coniche, spirali fonografiche.

## PREDISPOSIZIONI



fig.1

### Adduzione liquido refrigerante fig.1

Nelle TA-CENTER il liquido refrigerante esce da due ugelli orientabili posti a fianco della slitta dopo aver attraversato il cono ed il corpo rotante della testa. Questo notevole vantaggio assicura una maggiore durata dell'inserto, una maggiore velocità di taglio e l'ottenimento di buone finiture superficiali. L'adduzione centralizzata del liquido refrigerante non danneggia la TA-CENTER i cui labirinti interni sono protetti da anelli di tenuta. È consigliabile non superare i **40 BAR** di pressione.



fig.2

### Bilanciatura fig.2

Le teste TA-CENTER sono state progettate con due contrappesi (5) per il bilanciamento automatico, che si muovono in senso opposto alla slitta (3) permettendo di lavorare ad un elevato numero di giri senza oscillazioni apprezzabili.

### U-Drive

La D'ANDREA ha sviluppato un gruppo di motorizzazione U-DRIVE standard (orizzontale e a 90°), sul quale possono essere montati diversi tipi di motori.

L'U-DRIVE può essere facilmente posizionata sulla macchina (vedere foto) con una piastra di supporto (18) di adattamento alla macchina collegata e fissata ai fori (C) presenti sul fronte del mandrino.

Altre configurazioni speciali possono essere fornite a richiesta.

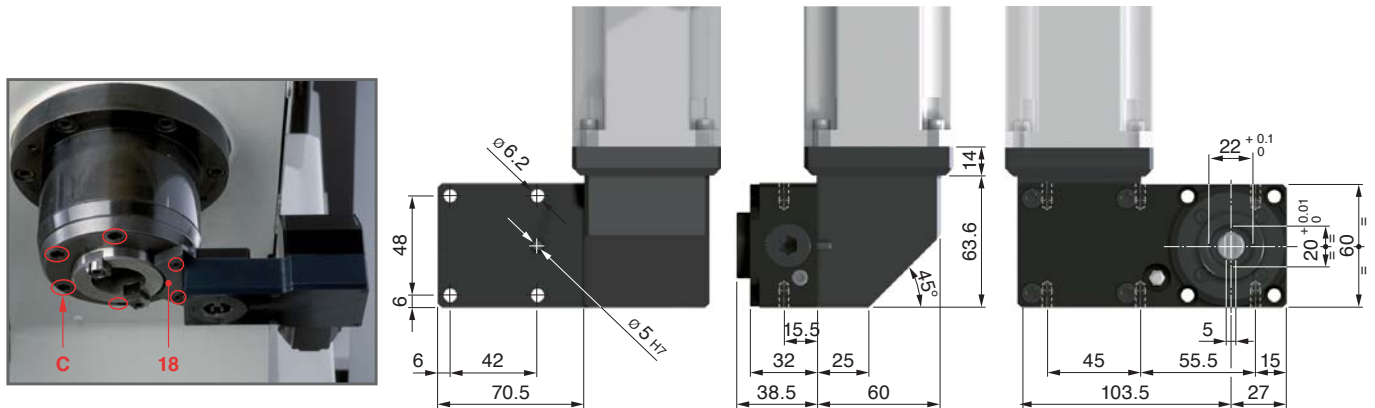

### Montaggio U-DRIVE - TA-CENTER

Per una corretta installazione dell'U-DRIVE e della TA-CENTER, seguire con attenzione le seguenti istruzioni:

1. Montare il cono sulla TA-CENTER, rilevare la distanza B tra l'arrivo calibro del cono (4) e il piano del perno di ritegno (9). Calcolare la quota X con la formula  $X=B+4\text{mm}$ .

**Attenzione**, se vengono impiegate più teste sulla stessa macchina, calcolare la quota X utilizzando il valore B più basso.

2. Montare la piastra (18) e l'U-DRIVE sulla macchina secondo Layout e rilevare la distanza F tra l'arrivo calibro del mandrino e il piano dell'U-DRIVE.

La distanza F dovrà essere uguale alla quota X. La piastra (18) viene fornita con uno spessore maggiorato rispetto a quanto indicato nel layout, per ottenere le due distanze F e X uguali, deve essere rasato lo spessore della piastra (18). Dopo aver regolato l'altezza F, rimontare l'U-DRIVE prestando attenzione al suo allineamento, alla posizione dell'albero di trasmissione (22) e alla distanza (23) tra l'asse dell'albero di trasmissione (22) e il centro del mandrino macchina.

**⚠** La flangia di guida (24) deve essere rivolta sempre verso il centro del mandrino.

3. Per allineare la TA-CENTER all'U-DRIVE, rimuovere i due grani di bloccaggio (21) dell'anello di orientamento (8), a destra e a sinistra del punto di riferimento bianco, e sostituirli momentaneamente con due grani più lunghi, rendendo l'anello solidale al corpo fisso. Avvitare i 4 grani dell'anello fino a farli appoggiare leggermente al cono (4) (fig.1-2). Dopo aver verificato che la testa si trovi nella posizione di **HOME POSITION**, che la corsa della slitta sia 0 e che l'albero della trasmissione (22) dell'U-DRIVE sia allineato al perno di ritegno (9) della testa, orientamento mandrino (M19), montare manualmente la testa in macchina. Inserire il cono (4) nel mandrino ruotando il corpo fisso (1) fino all'U-DRIVE, dopo aver ottenuto l'allineamento tra TA-CENTER e U-DRIVE, bloccare la TA-CENTER in macchina e serrare tutti i grani (21), rimettendo uno alla volta i due grani originali. Durante questa operazione prestare attenzione all'altezza tra l'anello (8) e il corpo fisso (1) (fig.3). Caricare e scaricare la TA-CENTER manualmente un paio di volte per verificarne l'allineamento.

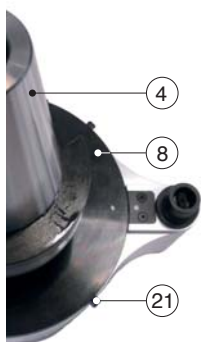

fig.1

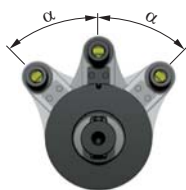

fig.2

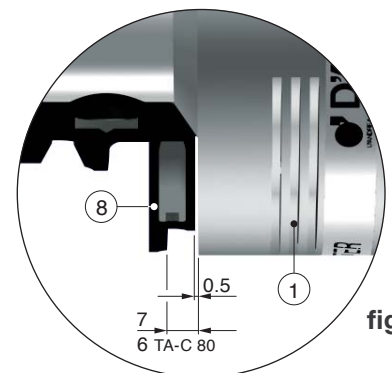

fig.3





Le asportazioni sono indicative per condizioni di lavoro normali su acciai con durezza 160-200 HB, ( $K_s$  medio = 2000 N/mm<sup>2</sup>) Vt consigliata 120/160 m/min.

I valori ottimali ed i tempi di lavoro dovranno essere determinati con delle prove.



	TA-C 80	TA-C 100	TA-C 125	TA-C 160	TA-C 200
<b>D</b>	8 ~ 62	10 ~ 72	10 ~ 81	20 ~ 109	20 ~ 124
<b>L</b>	60	75	75	125	125
<b>D1</b>	62 ~ 102	72 ~ 122	63 ~ 131	103 ~ 203	88 ~ 218
<b>L1</b>	80	100	100	160	160
<b>D2</b>	112 ~ 160	122 ~ 200	131 ~ 250	203 ~ 320	218 ~ 400
<b>L2</b>	20.5	25.5	25.5	38.5	38.5

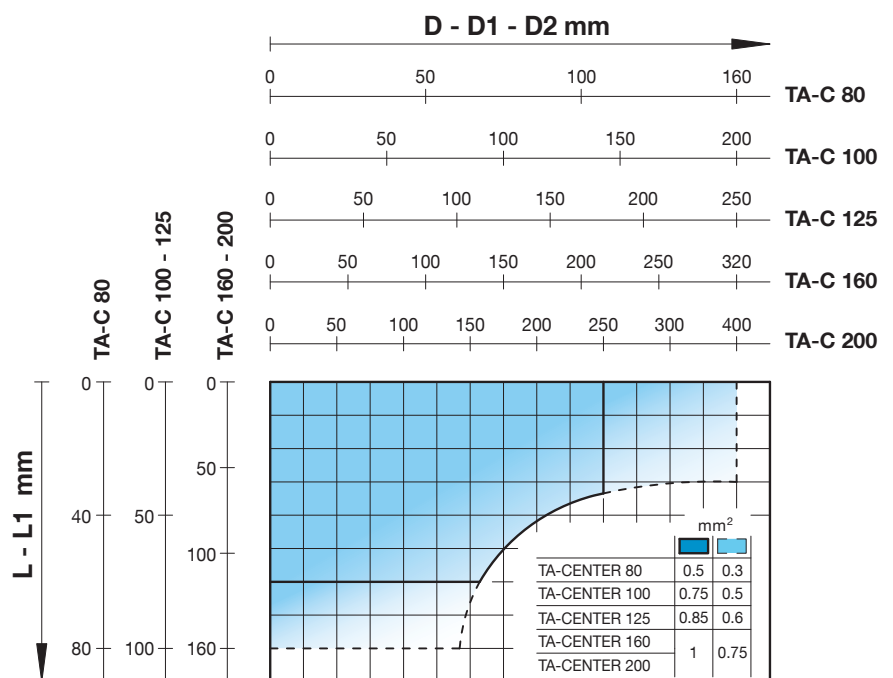

Per un buon impiego della testa TA-CENTER e per salvaguardarne l'integrità è consigliato seguire il grafico sottostante che indica il **numero di giri massimo** in funzione della corsa della slitta.

## MAX VELOCITÀ DI ROTAZIONE

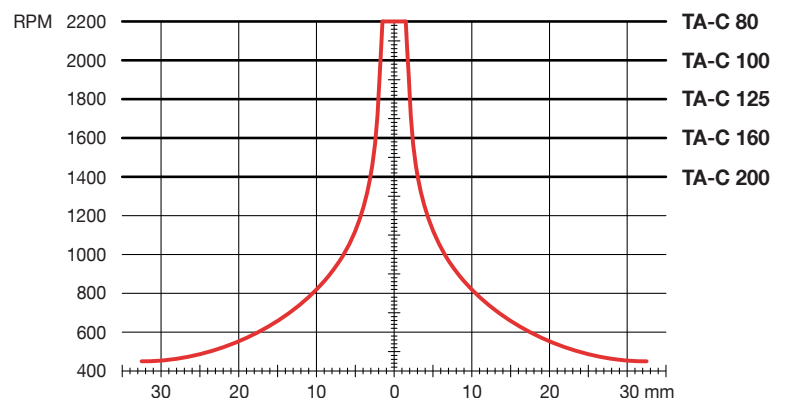



K02



REF.	CODE
K02 TA-C 80 I.65	501250800650
K02 TA-C 80 I.80	501250800800
K02 TA-C 100 I.80	501251000800
K02 TA-C 100 I.110	501251001100
K02 TA-C 125 I.80	501251250800
K02 TA-C 125 I.110	501251251100
K02 TA-C 160 I.110	501251601100
K02 TA-C 200 I.110	501252001100

K03



1 P120 1 P130

REF.	CODE
KIT K03 TA-C 80	501200300801
KIT K03 TA-C 100-125	501200301001
KIT K03 TA-C 160-200	501200301601

MHD'

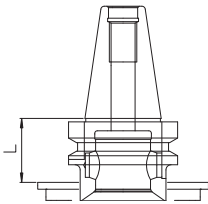

REF.	MHD'	TA-C 80		
		CODE	L	X
DIN 69871-A30 MHD'40.45.5	40	41 6 40 01 030 20	35	22
DIN 69871-A40 MHD'40.45	40	41 6 40 01 040 20	34.5	21.5
MAS403 BT30 MHD'40.35.5	40	41 6 40 01 030 30	25	12
MAS403 BT40 MHD'40.45	40	41 6 40 01 040 30	34.5	21.5

REF.	MHD'	TA-C 100		TA-C 125			
		CODE	L	X	CODE	L	X
DIN69871-A40 MHD'50.48	50	41 6 50 01 040 20	36.5	21.5	41 6 50 01 040 20	36.5	21.5
DIN69871-A40 MHD'50.56	50	41 6 50 01 040 70	44.5	29.5	41 6 50 01 040 70	44.5	29.5
MAS403 BT40 MHD'50.38.5	50	41 6 50 01 040 39	27	12	41 6 50 01 040 39	27	12
MAS403 BT40 MHD'50.48	50	41 6 50 01 040 30	36.5	21.5	41 6 50 01 040 30	36.5	21.5
MAS403 BT40 MHD'50.56	50	41 6 50 01 040 80	44.5	29.5	41 6 50 01 040 80	44.5	29.5
HSK-A63 MHD'50.66	50	41 6 50 15 063 20	54.5	39.5	41 6 50 15 063 20	54.5	39.5
ANSI/CAT40 MHD'50.66	50	41 6 50 01 040 40	54.5	39.5	41 6 50 01 040 40	54.5	39.5

REF.	MHD'	TA-C 160		TA-C 200			
		CODE	L	X	CODE	L	X
DIN69871-A50 MHD'80.48	80	41 6 80 01 050 29	36.5	21.5	41 6 80 01 050 29	36.5	21.5
MAS403 BT50 MHD'80.50	80	41 6 80 01 050 39	38.5	23.5	41 6 80 01 050 39	38.5	23.5
HSK-A100 MHD'80.88	80	41 6 80 15 100 20	76.5	61.5	41 6 80 15 100 20	76.5	61.5
ANSI/CAT50 MHD'80.62	80	41 6 80 01 050 40	50.5	35.5	41 6 80 01 050 40	50.5	35.5

Gamma completa dei coni a pag.10

P120

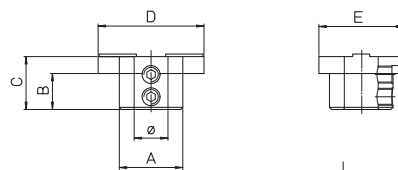

	REF.	CODE	ØH7	A	B	C	D	E	Kg.
TA-C 80	P120	431550160200	16	30	14	20	40	32	0.1
TA-C 100-125	P120	431550160250	16	30	17	25	50	40	0.2
TA-C 160-200	P120	431550250380	25	47	27.5	38	76	54	0.55

P130

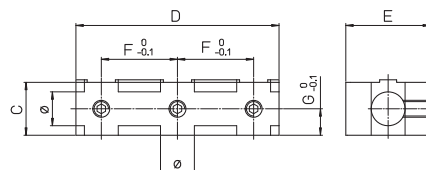

	REF.	CODE	ØH7	C	D	E	F	G	Kg.
TA-C 80	P130	433032200800	16	20	80	32	30	10.5	0.3
TA-C 100-125	P130	433040250950	16	25	95	40	37	10.5	0.5
TA-C 160-200	P130	433054381520	25	38	152	54	59.5	16.5	1.6

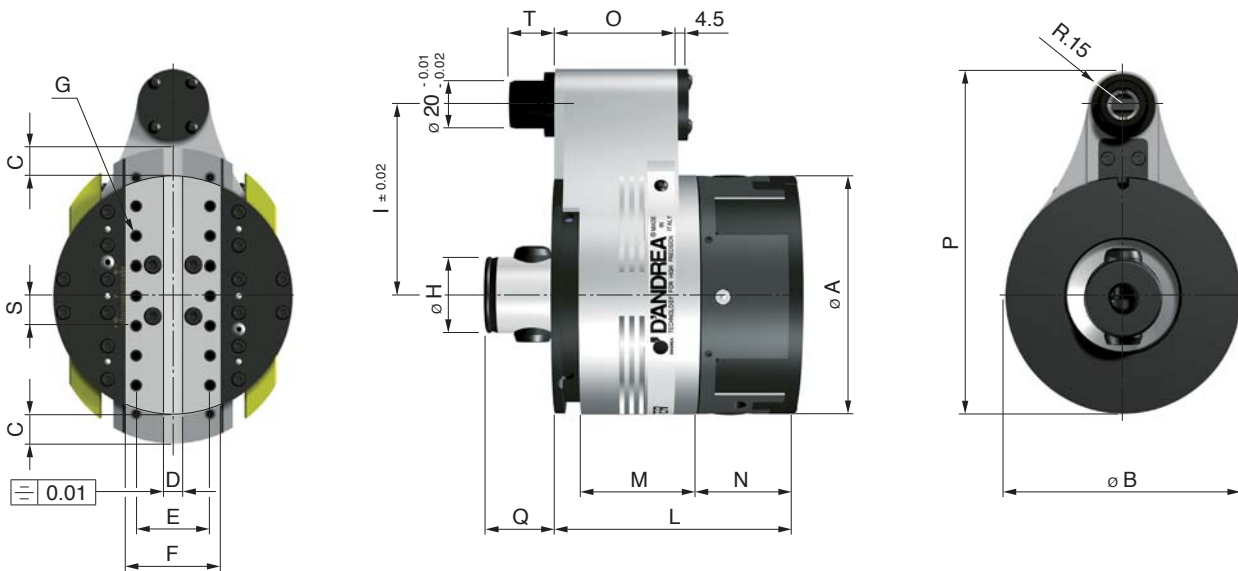

DATI TECNICI		TA-C 80	TA-C 100	TA-C 125	TA-C 160	TA-C 200
Ø A	mm	80	100	125	160	200
Ø B	mm	80.5	100.5	100.5	160.5	200.5
C corsa radiale	mm	± 10	± 12	± 17	± 25	± 32.5
D	mm	6 <sup>+0.04</sup> <sub>+0.02</sub>	8 <sup>+0.04</sup> <sub>+0.02</sub>	10 <sup>+0.04</sup> <sub>+0.02</sub>	10 <sup>+0.04</sup> <sub>+0.02</sub>	10 <sup>+0.04</sup> <sub>+0.02</sub>
E	mm	25	31	40	56	63
F	mm	32	40	45	56	63
G	mm	M 3	M 4	M 5	M 5	M 5
Ø H	mm	(MHD'40) 25 <sup>-0.004</sup> <sub>-0.006</sub>	32 <sup>-0.005</sup> <sub>-0.008</sub> (MHD'50)	42 <sup>-0.005</sup> <sub>-0.008</sub> (MHD'80)	42 <sup>-0.005</sup> <sub>-0.008</sub> (MHD'80)	42 <sup>-0.005</sup> <sub>-0.008</sub> (MHD'80)
I	mm	65/80	80/110	110	110	110
L	mm	80	100	104	136	136
M	mm	37.5	48.5	69	69	69
N	mm	32.5	40.5	56	56	56
O	mm	43	51	61.5	61.5	61.5
P	mm	120 / 135	145 / 175	205	205	205
Q	mm	23.5	29	44.5	44.5	44.5
S	mm	10	12.5	12.5	12.5	12.5
T	mm	17	19	19	19	19
Avanzamento	mm/min	1 ÷ 500				
Forza radiale	daN	100	150	250	250	250
Massima velocità	RPM	2200	2000	1800	1600	1400
Momento torcente	daNm	200	400	800	800	800
Peso senza cono	Kg	2.9	4.8	6.5	16.8	21.4
Precisione in alesatura		H7				
Ø max. lavorabile	mm	160	200	250	320	400
Cap. max asportazione su Acc.C40	mm <sup>2</sup>	0,5	0,75	0,85	1	1
Rugosità	Ra	0.8 - 1.2				

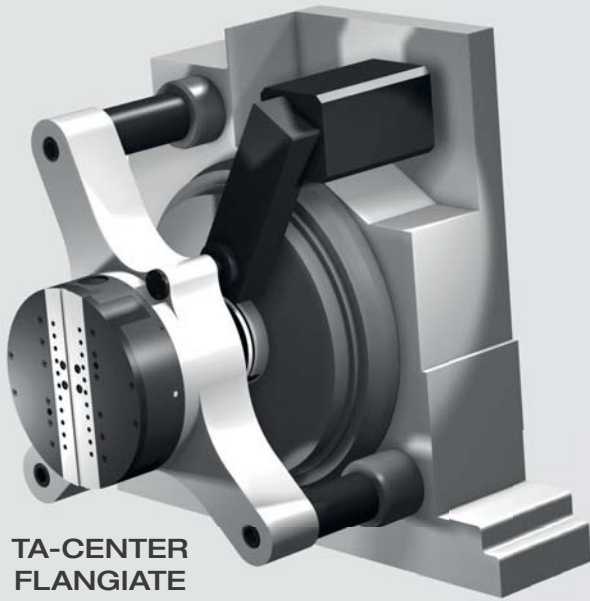

TA-CENTER  
FLANGIATE

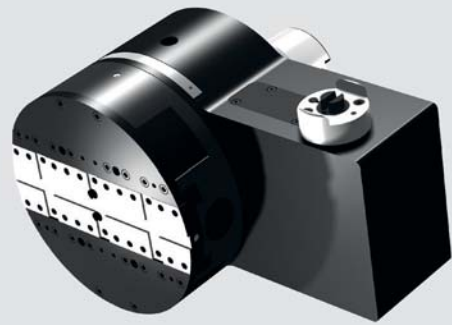

TA-CENTER  
90°



TA-CENTER  
MACCHINE SPECIALI

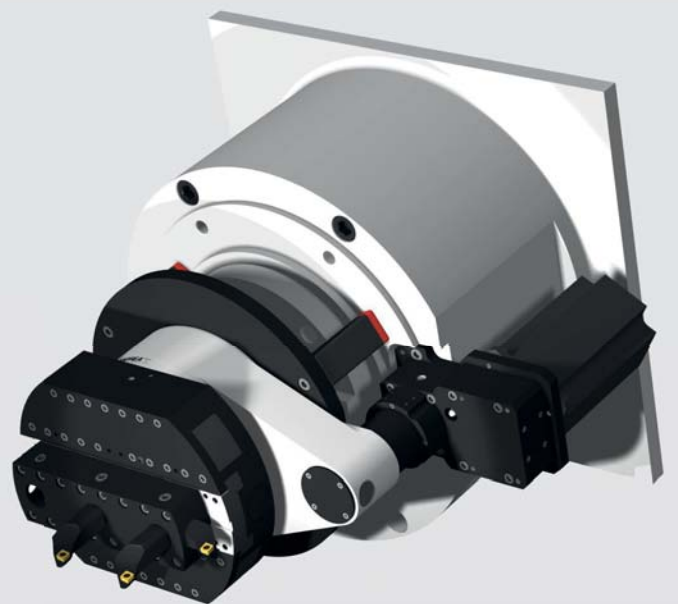

TA-CENTER  
MISURE SPECIALI





# TA-TRONIC

**TA-TRONIC** Teste progettate per essere applicate manualmente su piccole alesatrici, centri di lavoro e macchine speciali.

Il motore integrato si collega al CN e gestisce lo spostamento della slitta portautensile.

Il corpo fisso viene sostenuto da una flangia o, per operazioni poco gravose, da un semplice perno antirotazione.



## COMPONENTI

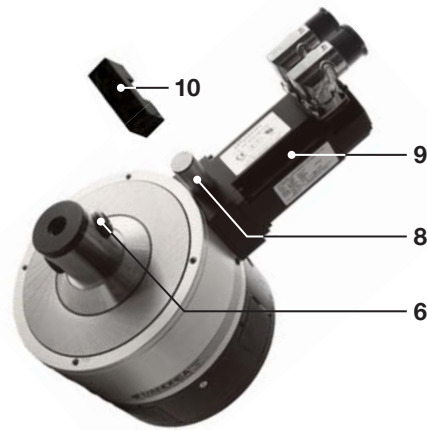

- |                                 |  |
|---------------------------------|--|
| 1. Corpo fisso                  | 6. Attacco MHD'                                    |
| 2. Corpo rotante                | 7. Ugelli di uscita del liquido lubro-refrigerante |
| 3. Slitta portautensili         | 8. Perno antirotazione                             |
| 4. Cono intercambiabile         | 9. Motore  |
| 5. Contrappesi di equilibratura | 10. Tassello antirotazione                         |

## COMANDO



CNC

Il comando delle teste TA-TRONIC avviene tramite il collegamento diretto all'asse "U" del controllo numerico della macchina utensile che permette lavorazioni di alesatura, sfacciatura interna, esterna e sottosquadra, tornitura interna ed esterna, canalini, spirali fonografiche, filettature e alesature coniche, alesature coniche anche variabili, raggiature concave e convesse mediante l'interpolazione con gli altri assi.

## PREDISPOSIZIONI

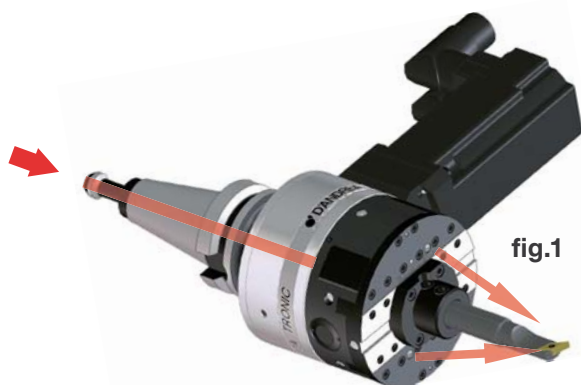

fig.1

### Adduzione liquido refrigerante fig.1

Nelle TA-TRONIC il liquido refrigerante esce da due ugelli orientabili posti a fianco della slitta dopo aver attraversato il cono ed il corpo rotante della testa. Questo notevole vantaggio assicura una maggiore durata dell'inserto, una maggiore velocità di taglio e l'ottenimento di buone finiture superficiali.

L'adduzione centralizzata del liquido refrigerante non danneggia la TA-TRONIC i cui labirinti interni sono protetti da anelli di tenuta.

È consigliabile non superare i **40 BAR** di pressione.

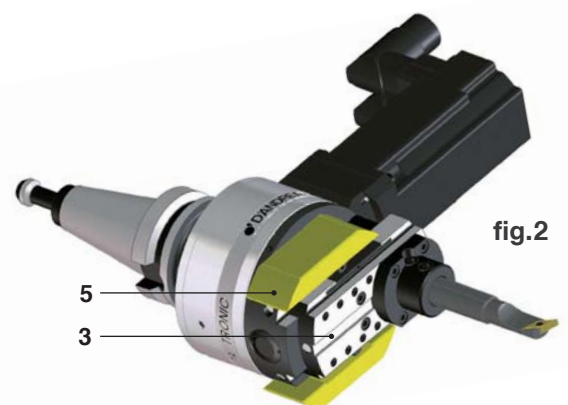

fig.2

### Bilanciatura fig.2

Le teste TA-TRONIC sono state progettate con due contrappesi (5) per il bilanciamento automatico, che si muovono in senso opposto alla slitta (3) permettendo di lavorare ad un elevato numero di giri senza oscillazioni apprezzabili.





# CAPACITÀ DI ASPORTAZIONE

Le asportazioni sono indicative per condizioni di lavoro normali su acciai con durezza 160-200 HB, ( $K_s$  medio = 2000 N/mm<sup>2</sup>)  
 $V_t$  consigliata 120/160 m/min.  
 I valori ottimali ed i tempi di lavoro dovranno essere determinati con delle prove.



	TA-T 100	TA-T 125	TA-T 160	TA-T 200
D	10 ~ 72	10 ~ 81	20 ~ 109	20 ~ 124
L	75	75	125	125
D1	72 ~ 122	63 ~ 131	103 ~ 203	88 ~ 218
L1	100	100	160	160
D2	122 ~ 200	131 ~ 250	203 ~ 320	218 ~ 400
L2	25.5	25.5	38.5	38.5

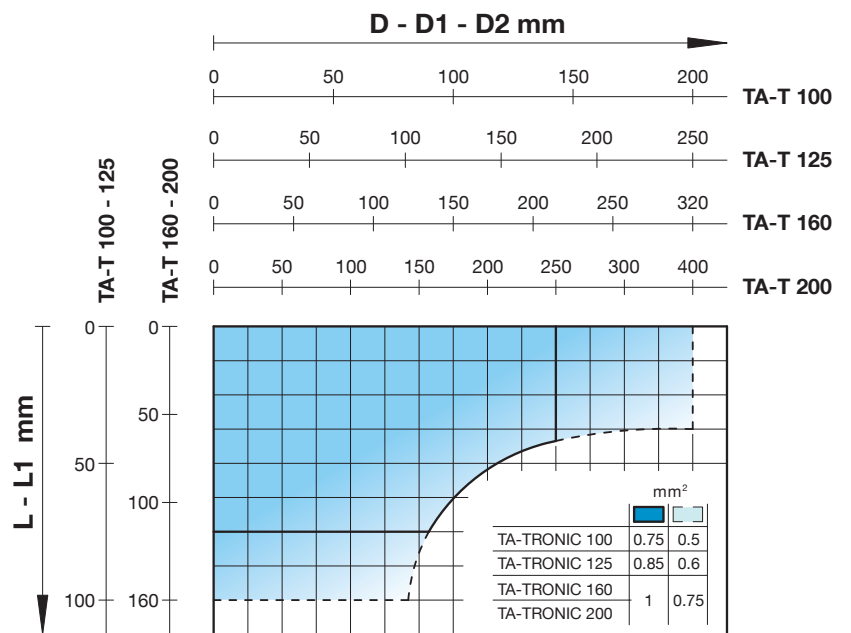

Per un buon impiego della testa TA-TRONIC e per salvaguardarne l'integrità è consigliato seguire il grafico sottostante che indica il **numero di giri massimo** in funzione della corsa della slitta.

## MAX VELOCITÀ DI ROTAZIONE

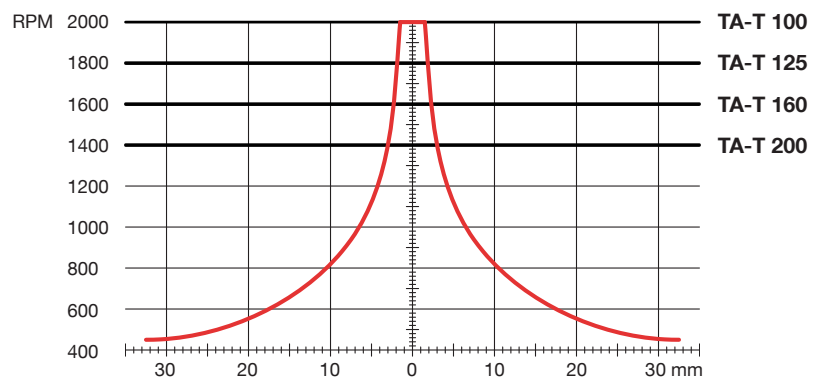

### K02



REF.	CODE
K02 TA-T 100 1FK7022-5AK74-1HA5	501201000400
K02 TA-T 100 FANUC bis 1/6000	501201000800
K02 TA-T 125 1FK7022-5AK74-1HA5	501201250400
K02 TA-T 125 FANUC bis 1/6000	501201250800
K02 TA-T 160 1FK7032-2AK74-1EA2	501201600400
K02 TA-T 160 FANUC bis 1/6000	501201600800
K02 TA-T 200 1FK7032-2AK74-1EA2	501202000400
K02 TA-T 200 FANUC bis 1/6000	501202000800

### K03



1 P120      1 P130

REF.	CODE
KIT K03 TA-T 100-125	501200301001
KIT K03 TA-T 160-200	501200301601

### MHD'

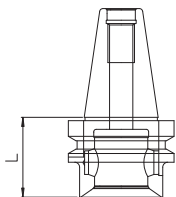

REF.	MHD'	TA-T 100		TA-T 125	
		CODE	L	CODE	L
DIN69871-A40 MHD'50.48	50	41 6 50 01 040 20	36.5	41 6 50 01 040 20	36.5
DIN69871-A40 MHD'50.56	50	41 6 50 01 040 70	44.5	41 6 50 01 040 70	44.5
MAS403 BT40 MHD'50.38.5	50	41 6 50 01 040 39	27	41 6 50 01 040 39	27
MAS403 BT40 MHD'50.48	50	41 6 50 01 040 30	36.5	41 6 50 01 040 30	36.5
MAS403 BT40 MHD'50.56	50	41 6 50 01 040 80	44.5	41 6 50 01 040 80	44.5
HSK-A63 MHD'50.66	50	41 6 50 15 063 20	54.5	41 6 50 15 063 20	54.5
ANSI/CAT40 MHD'50.66	50	41 6 50 01 040 40	54.5	41 6 50 01 040 40	54.5

REF.	MHD'	TA-T 160		TA-T 200	
		CODE	L	CODE	L
DIN69871-A50 MHD'80.48	80	41 6 80 01 050 29	36.5	41 6 80 01 050 29	36.5
MAS403 BT50 MHD'80.50	80	41 6 80 01 050 39	38.5	41 6 80 01 050 39	38.5
HSK-A100 MHD'80.88	80	41 6 80 15 100 20	76.5	41 6 80 15 100 20	76.5
ANSI/CAT50 MHD'80.62	80	41 6 80 01 050 40	50.5	41 6 80 01 050 40	50.5

Gamma completa dei coni a pag.10

### P120

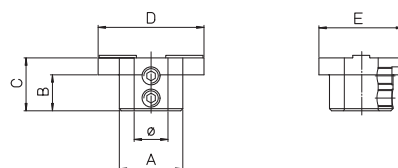

	REF.	CODE	ØH7	A	B	C	D	E	Kg.
TA-T 100-125	P120	431550160250	16	30	17	25	50	40	0.2
TA-T 160-200	P120	431550250380	25	47	27.5	38	76	54	0.55

### P130

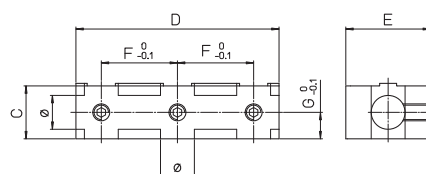

	REF.	CODE	ØH7	C	D	E	F	G	Kg.
TA-T 100-125	P130	433040250950	16	25	95	40	37	10.5	0.5
TA-T 160-200	P130	433054381520	25	38	152	54	59.5	16.5	1.6

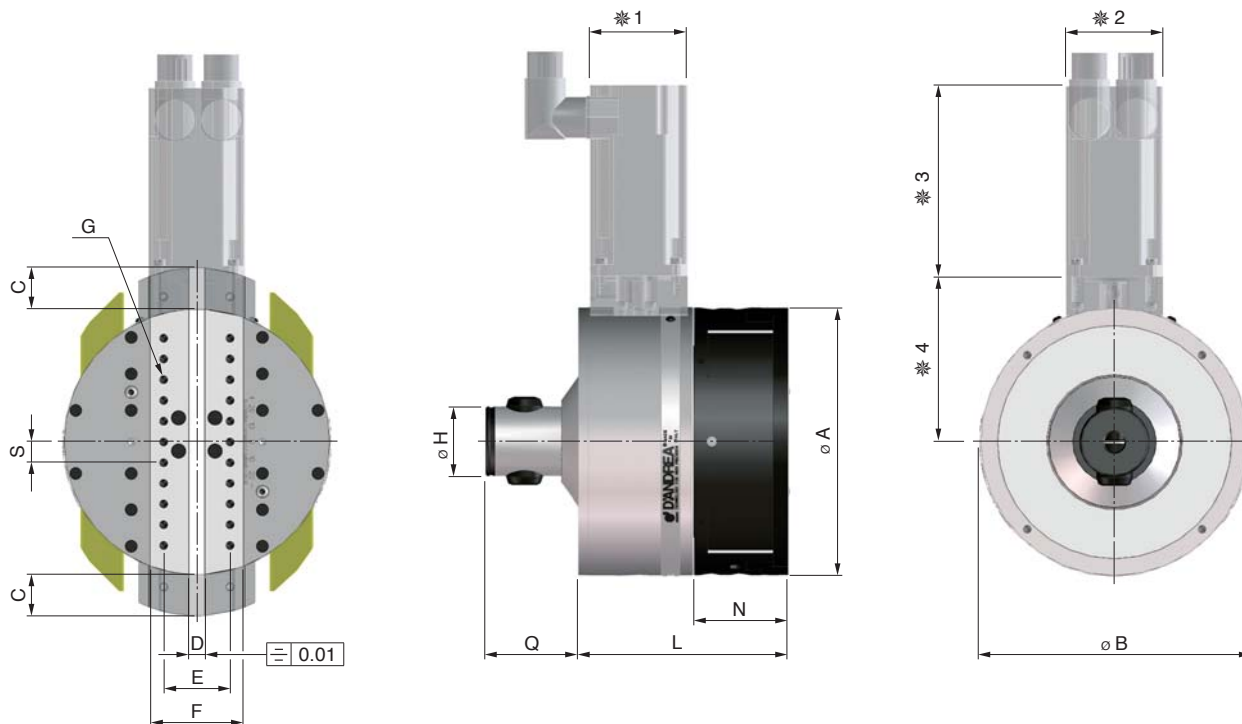
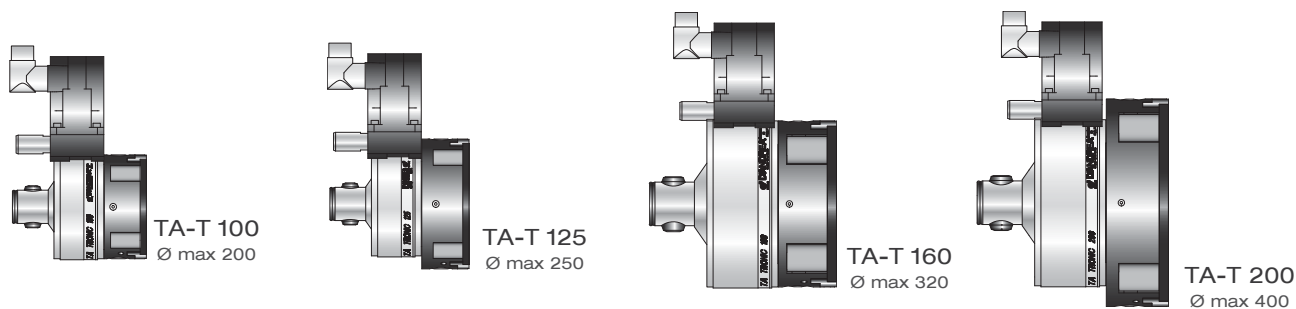

DATI TECNICI		TA-T 100	TA-T 125	TA-T 160	TA-T 200
Ø A	mm	100	125	160	200
Ø B	mm	100.5		160.5	
C corsa radiale	mm	± 12	± 17	± 25	± 32.5
D	mm	8 <sup>+0.04</sup> / <sub>+0.02</sub>		10 <sup>+0.04</sup> / <sub>+0.02</sub>	
E	mm	31		40	
F	mm	40	45	56	63
G	mm	M 4		M5	
Ø H	mm	32 <sup>-0.005</sup> / <sub>-0.008</sub> (MHD'50)		42 <sup>-0.005</sup> / <sub>-0.008</sub> (MHD'80)	
L	mm	89	93	125	125
N	mm	40.5	44.5	56	56
Q	mm	29		55.45	
S	mm	12.5			
Avanzamento	mm/min	1 ÷ 500			
Forza radiale	daN	150		250	
Massima velocità	RPM	2000	1800	1600	1400
Momento torcente	daNm	400		800	
Peso senza cono	Kg	4.8	6.5	16.8	21.4
Precisione in alesatura		H7			
Ø max. lavorabile	mm	200	250	320	400
Cap. max asportazione su Acc.C40	mm <sup>2</sup>	0,75	0,85	1	
Rugosità	Ra	0.8 - 1.2			

Dimensioni Motori SIEMENS / FANUC	TA-T 100 / TA-T 125		TA-T 160 / TA-T 200	
	Siemens 1FK7022	FANUC βis 1/6000	Siemens 1FK7032	FANUC βis 1/6000
* 1	55	60	72	60
* 2	55	60	72	60
* 3	178	111.5	173	111.5
* 4	92		118,5	

\* Misure indicative che possono variare al variare del motore

# U-COMAX

**U-COMAX** teste a comando assiale destinate all'impiego su macchine transfer o unità speciali.  
Lo spostamento della slitta è gestito da un gruppo di motorizzazione U-DRIVE  
montato posteriormente all'unità mandrino e gestito dal CN.  
Disponibile l'opzione Synchro.<sup>®</sup>

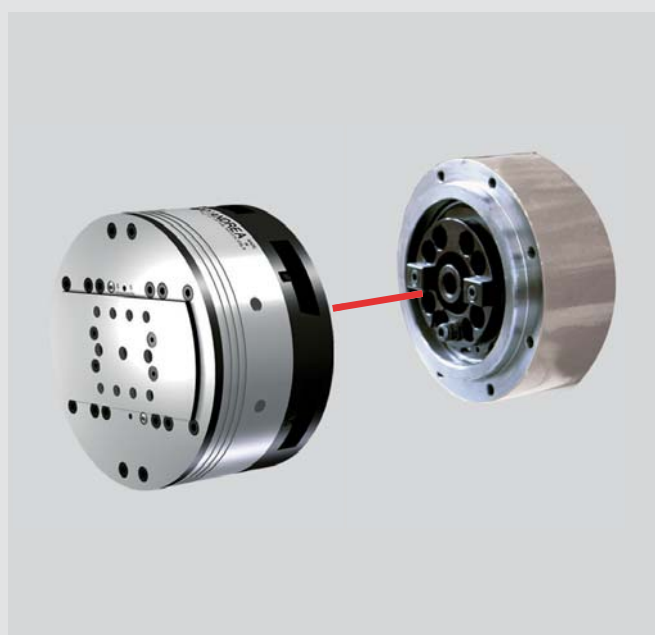
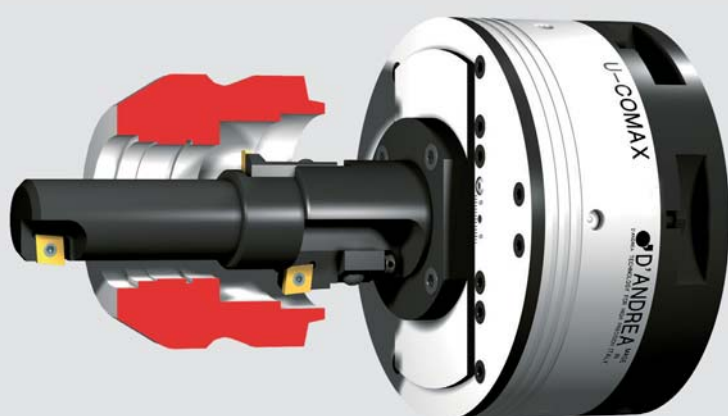



1. Flangia di adattamento alla macchina
2. Corpo rotante
3. Slitta portautensili
4. Albero di trasmissione

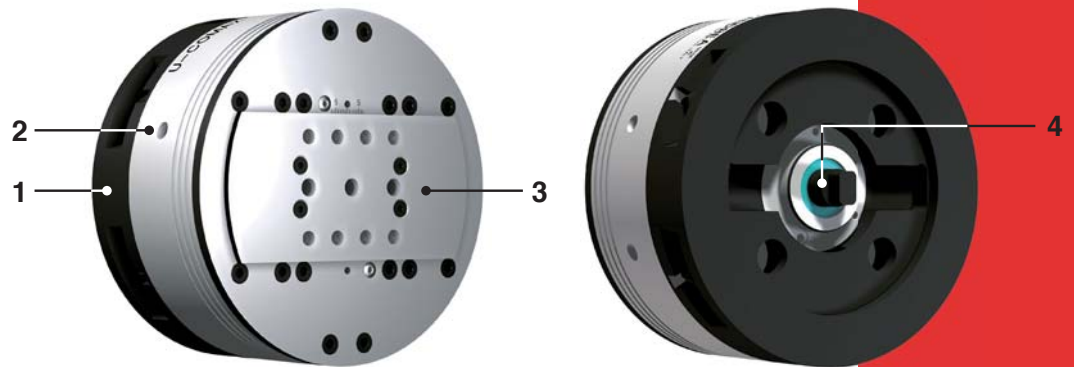

1. Flangia di adattamento anteriore
2. Flangia di trascinamento
3. Flangia di adattamento posteriore
4. Albero di trasmissione

## UNITÀ DI COMANDO MECCANICA ( U-DRIVE )

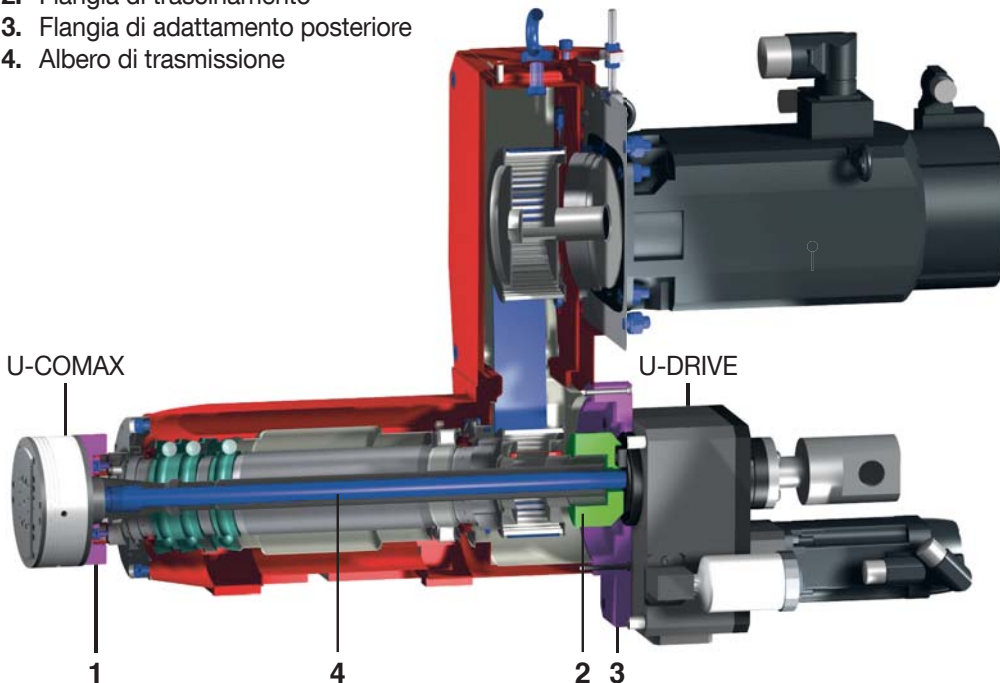

La motorizzazione U-Drive per le teste U-Comax viene montata posteriormente al mandrino della macchina, viene gestito da un asse del controllo numerico e collegata meccanicamente alla presa di moto della teste U-Comax con un albero di trasmissione che attraversa il mandrino della macchina stessa. La motorizzazione U-Drive può assumere diverse configurazioni a seconda dell'applicazione e della forma costruttiva della macchina.

## PREDISPOSIZIONI

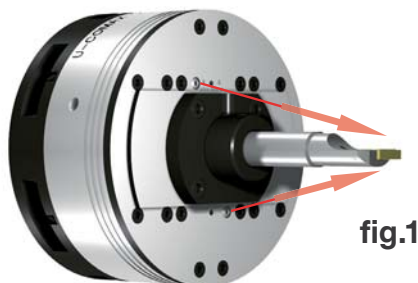

fig.1

### Adduzione liquido refrigerante fig.1

Nelle U-COMAX il liquido refrigerante esce da due ugelli orientabili posti a fianco della slitta dopo aver attraversato l'albero di trasmissione ed il corpo rotante della testa. Questo notevole vantaggio assicura una maggiore durata dell'inserto, una maggiore velocità di taglio e l'ottenimento di buone finiture superficiali.

L'adduzione centralizzata del liquido refrigerante non danneggia la U-COMAX i cui labirinti interni sono protetti da anelli di tenuta.

È consigliabile non superare i **40 BAR** di pressione.

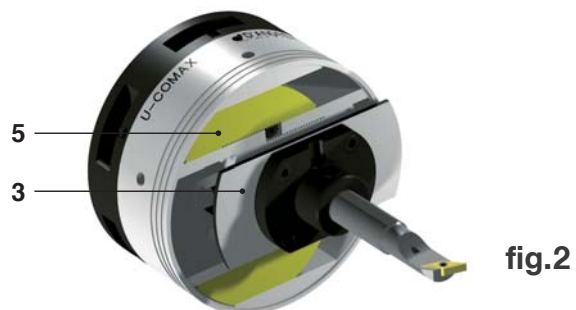

fig.2

### Bilanciatura fig.2

Le teste U-COMAX sono state progettate con due contrappesi (5) per il bilanciamento automatico, che si muovono in senso opposto alla slitta (3) permettendo di lavorare ad un elevato numero di giri senza oscillazioni apprezzabili.

Le U-COMAX vengono montate sulla macchina mediante una flangia di adattamento.  
Esistono due tipi di flangia.

### FLANGIA STANDARD

Viene progettata a seconda del tipo di macchina su cui viene montata la U-COMAX e può essere facilmente costruita dal cliente o fornita da D'ANDREA.

### FLANGIA CON CUSCINETTO:

E' una variante della Flangia standard che viene irrigidita con un cuscinetto a contatto obliquo : questo sistema funge da aiuto in caso di lavorazioni particolarmente gravose. Questa variante è fornibile solo per le U-COMAX 160 e 200.

### MONTAGGIO

La flangia di adattamento (1) viene montata sul mandrino, nel caso della versione con cuscinetti, sarà necessario anche un anello di collegamento (2), e successivamente la U COMAX verrà fissata alla flangia.

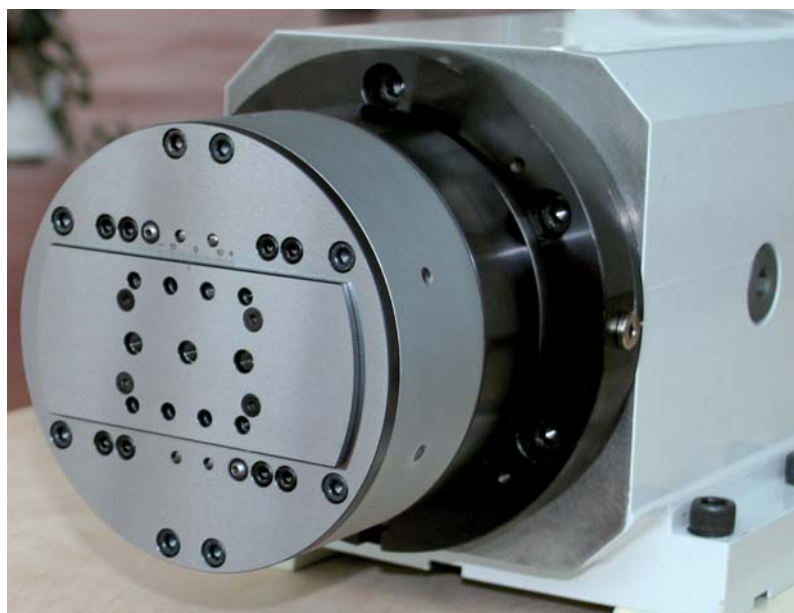
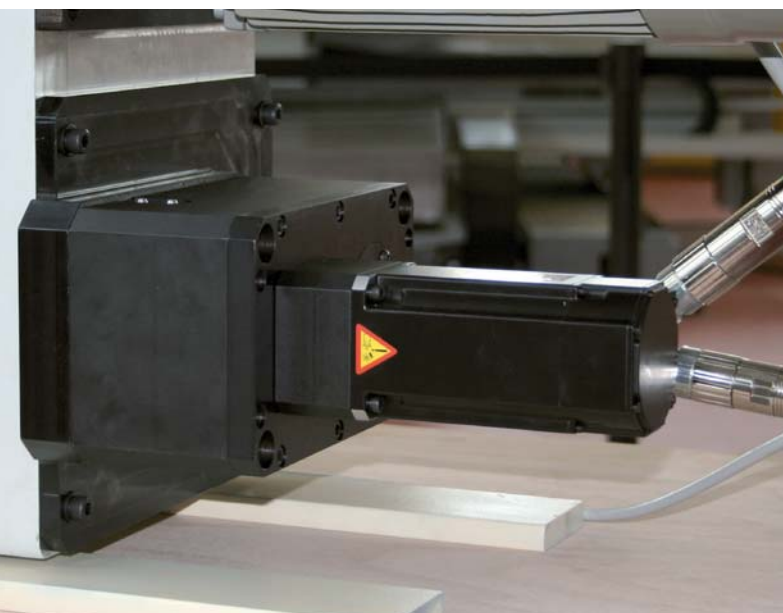
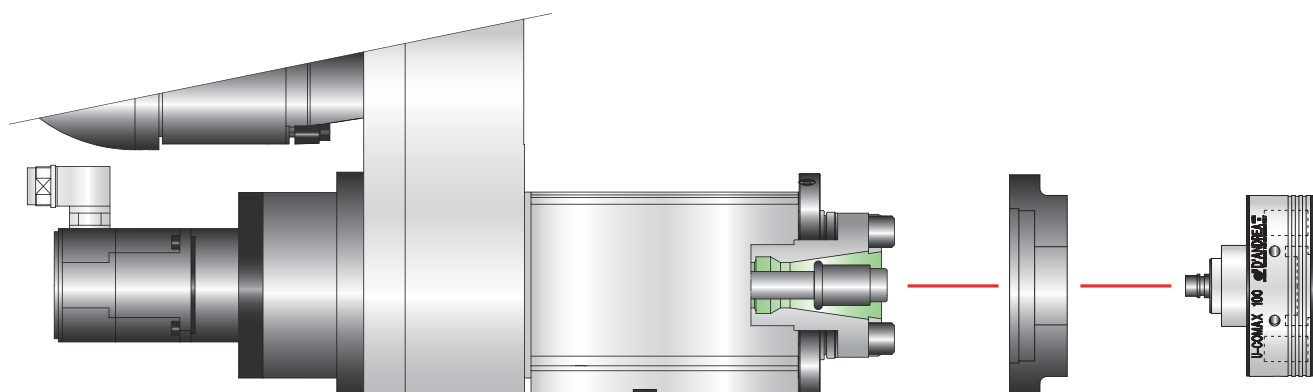
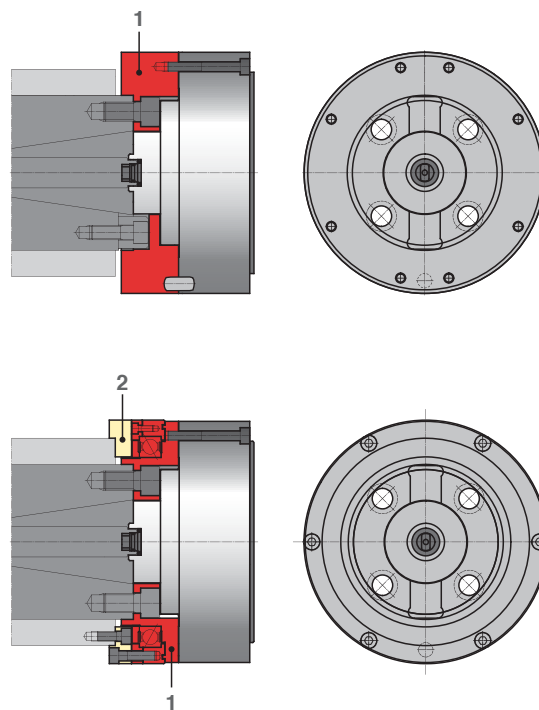

## CAPACITÀ DI ASPORTAZIONE

Le asportazioni sono indicative per condizioni di lavoro normali su acciai con durezza 160-200 HB, ( $K_s$  medio = 2000 N/mm<sup>2</sup>) Vt consigliata 120/160 m/min.

I valori ottimali ed i tempi di lavoro dovranno essere determinati con delle prove.

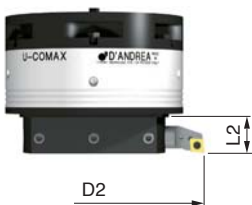

	CMX 125	CMX 160	CMX 200
D	10 ~ 72	20 ~ 81	20 ~ 200
L	75	100	125
D1	72 ~ 122	81 ~ 131	103 ~ 203
L1	100	125	160
D2	122 ~ 200	131 ~ 250	203 ~ 320
L2	25.5	38.5	38.5

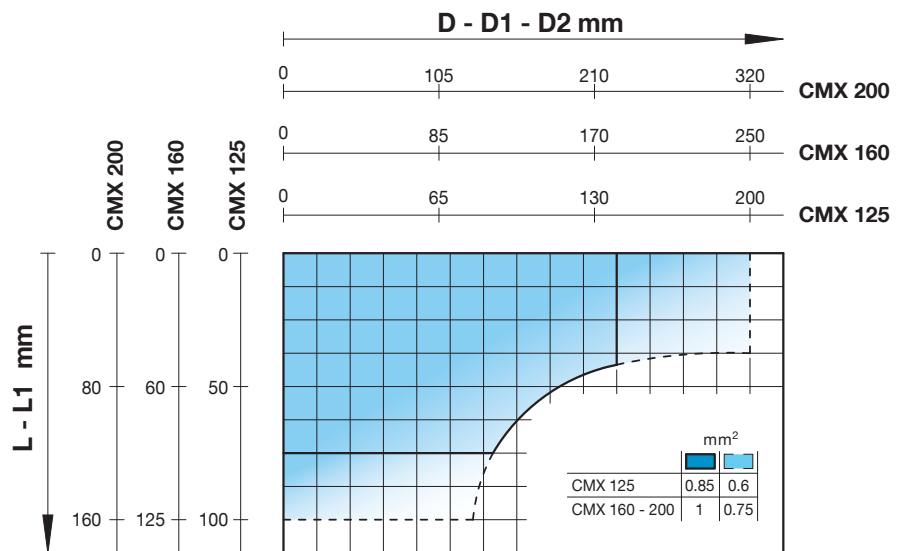

Per un buon impiego della testa U-COMAX e per salvaguardarne l'integrità è consigliato seguire il grafico sottostante che indica il numero di giri massimo in funzione della corsa della slitta.

## MAX VELOCITÀ DI ROTAZIONE

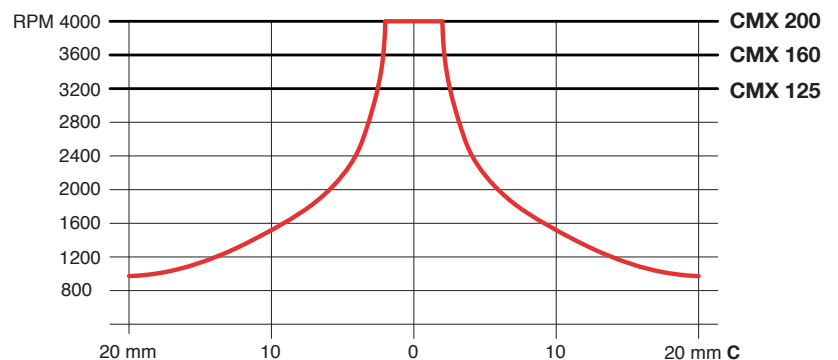



### K02 A RICHIESTA U-COMAX SPECIALI

REF.	CODE
K02 CMX 125	500512510001
K02 CMX 160	500516010001
K02 CMX 200	500520010001

### P120

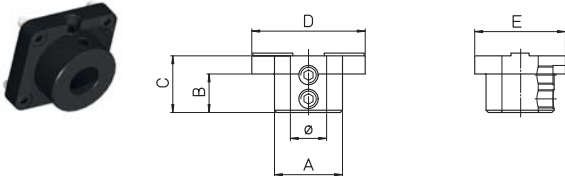

	REF.	CODE	ØH7	A	B	C	D	E	Kg.
CMX 125	P120	431550160261	16	30	16	25	48.5	46	0.2
CMX 160	P120	431550250390	25	47	26	38	61	58	0.55
CMX 200	P120	431550250391	25	56	24	38	76	72	0.9

### P130

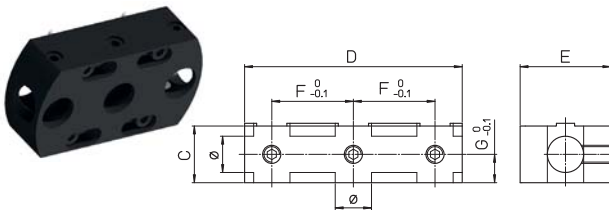

	REF.	CODE	ØH7	C	Ø D	E	F	G	Kg.
CMX 125	P130	433046250810	16	25	81	46	30	10.5	0.45
CMX 160	P130	433058381030	25	38	103	58	35	16.5	0.9
CMX 200	P130	433072381330	25	38	133	72	50	16.5	1.7

## DATI TECNICI

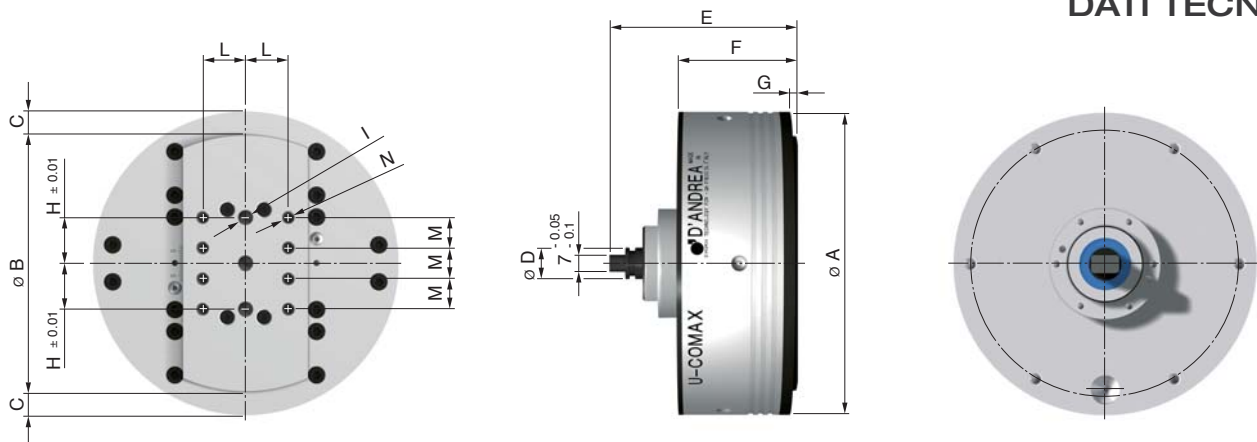

DATI TECNICI		CMX 125	CMX 160	CMX 200
Ø A	mm	125	160	200
Ø B	mm	105	128	167
C corsa radiale	mm	± 12	± 16	± 20
D	mm	13 <sup>-0.01</sup> <sub>-0.02</sub>		15 <sup>-0.01</sup> <sub>-0.02</sub>
E	mm	86.5		109.5
F	mm	52.5	69	68
G	mm	2.5		3.5
H	mm	18.75	24	30
Ø I	mm	6	8	10
L	mm	17.5	22.5	28
M	mm	12.5	16	20
Ø N	mm	M5	M6	M8
Avanzamento	mm/min		1 ÷ 500	
Forza radiale	daN	150		250
Massima velocità	RPM	3600	3200	2800
Momento torcente	daNm	400		800
Peso senza cono	Kg	3.2	9.8	11.5

# U-COMAX - Synchro

Il nuovo sistema brevettato **SYNCHRO**® D'Andrea si riferisce all'applicazione su una testa del concetto di sincronizzazione tra gli assi. Il controllo dell'avanzamento della slitta portautensili si esegue sincronizzando il motore che permette la rotazione del mandrino macchina con il motore dedicato allo spostamento della slitta portautensile. La sincronizzazione tra gli assi viene gestita dal controllo numerico della macchina. La soluzione consente di aumentare le prestazioni generali della testa, in particolare la velocità di avanzamento della slitta.

## Synchro®



### APPLICAZIONE DEL SISTEMA SYNCHRO D'ANDREA SU TESTE U-COMAX

1. Servomotore
2. Slitta portautensili
3. Macchina utensile C.N.C.
4. Mandrino della macchina utensile
5. Servomotore mandrino della macchina utensile
6. Albero di trasmissione

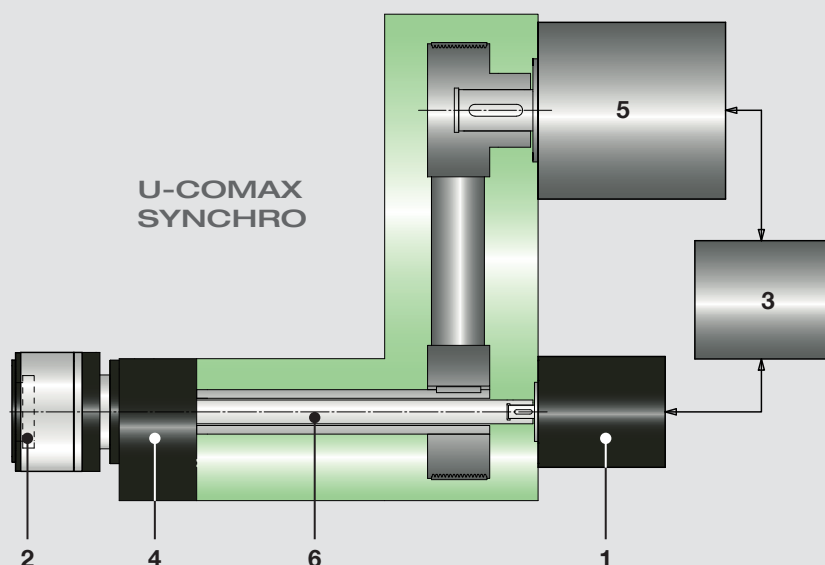

La figura schematizzata rappresenta una testa a comando assiale U-COMAX, dotata del sistema **SYNCHRO** D'Andrea, montata direttamente al gruppo mandrino della macchina utensile.

Il controllo dell'avanzamento della slitta portautensili avviene tramite il motore (1) montato posteriormente al gruppo mandrino e collegato meccanicamente alla testa U-COMAX con un albero di trasmissione che attraversa il mandrino della macchina stessa. Il motore (1) ruotando trasmette il moto alla slitta portautensili che si trova sul corpo rotante azionato dal mandrino macchina (5), quindi per comandare il movimento traslatorio della slitta occorre sincronizzare la rotazione del motore (1) con il motore mandrino (5). Per la sincronizzazione della U-COMAX all'unità macchina, è necessario che l'albero di trasmissione (6) compia lo stesso numero di giri del mandrino macchina (condizione con slitta ferma). La differenza tra la velocità di rotazione del motore (1) con il motore mandrino (5) genera lo spostamento radiale della slitta portautensili. La corretta sincronizzazione tra o due organi in rotazione si ottiene programmando adeguatamente il controllo numerico della macchina utensile.



# AUTORADIAL

**AUTORADIAL** teste automatiche a sfacciare, applicabili su centri di lavoro e macchin a CN senza bisogno di alcuna interfaccia elettronica od asservimento.

Eseguono automaticamente un ciclo di lavoro senza mai arrestare la rotazione del mandrino. Particolarmente indicate per l'esecuzione di sedi per anelli elastici e spirali fonografiche.

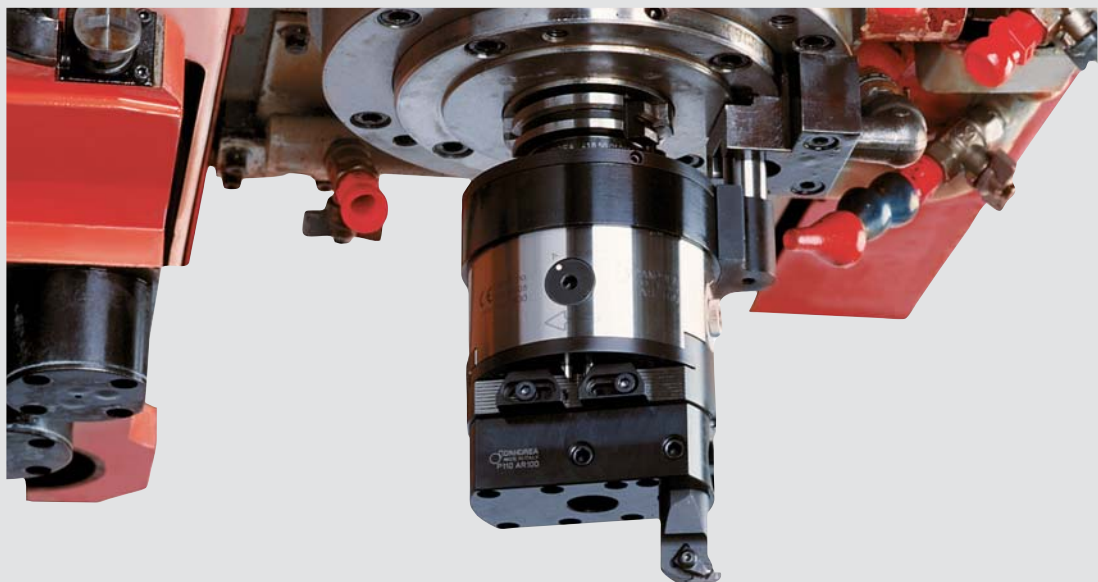
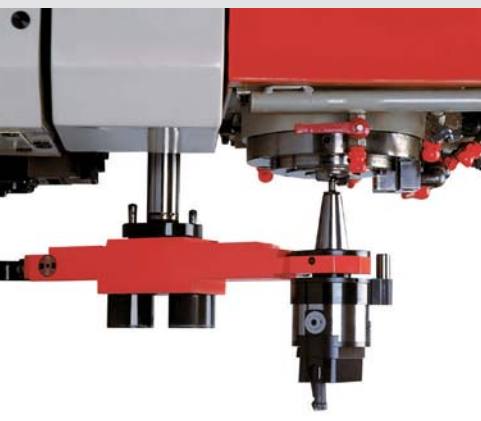
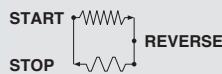
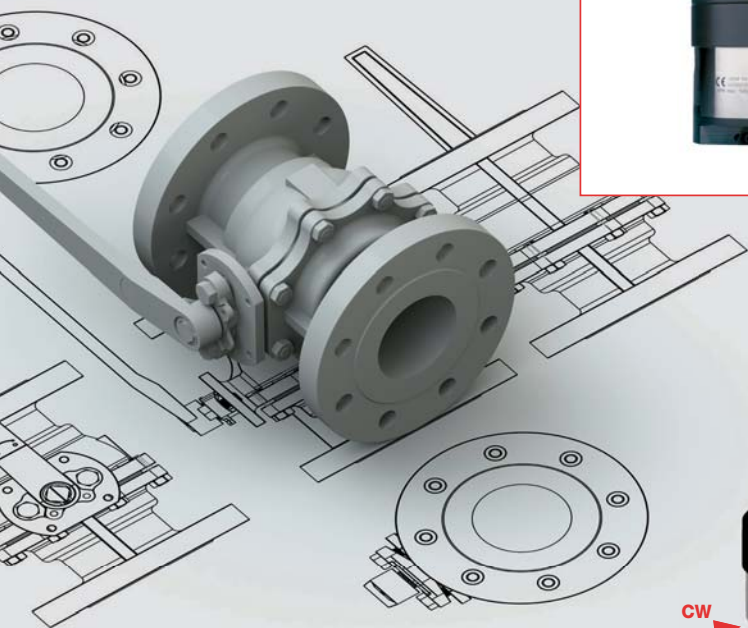

1. Selettore avanzamento (A), ritorno (R)
2. Tasselli di finecorsa
3. Vite comando
4. Perno di ritegno
5. Blocchetto avanzamenti intercambiabili
6. Slitta portautensili
7. Cono intercambiabile
8. Flangia di trascinamento
9. Corpo rotante

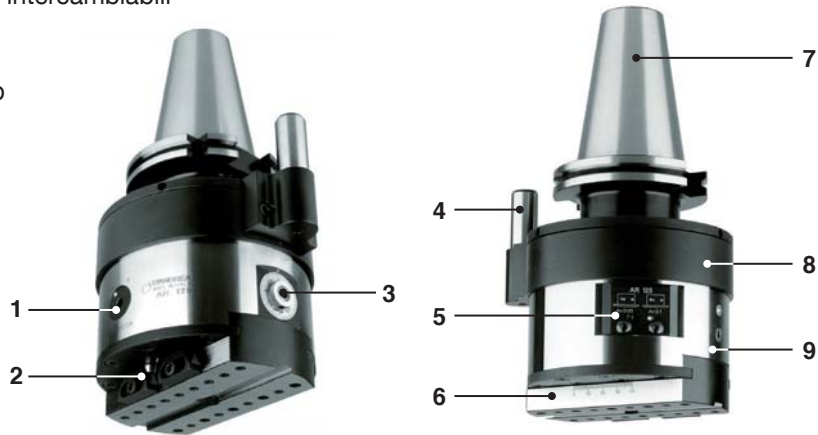

## MONTAGGIO

Nelle AUTORADIAL il movimento di avanzamento della slitta è ottenuto trattenendo la flangia di trascinamento (8) durante la rotazione del mandrino.

Il tassello (T) fornito con il KIT K-NC (K) va applicato ad una parte fissa attorno al mandrino rispettando le quote indicate.

Nel caso che la corsa del perno di ritegno non sia di  $5 \text{ mm} \pm 0,25$ , occorrerà regolare la posizione del tassello (T) per mezzo dello spessore S.

La regolazione dell'angolo  $\alpha$  è libera e la si ottiene allentando le 3 viti (A), ruotando la flangia (8) fino all'angolo desiderato e ribloccando le viti (A).

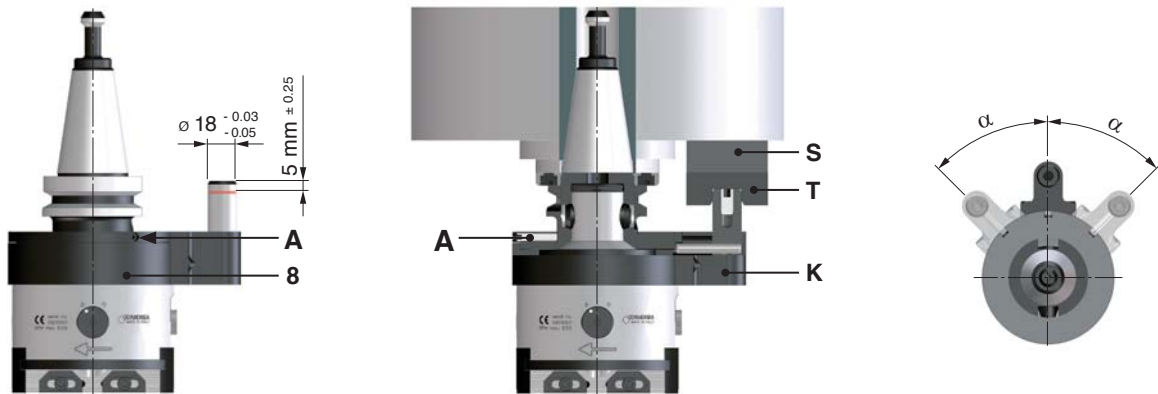

## ISTRUZIONI PER SOSTITUIRE IL BLOCCHETTO AVANZAMENTI

- a. Allentare viti 1
- b. Estrarre blocchetto 5
- c. Inserire nuovo blocchetto 5 lubrificato con grasso ISO-UNI tipo XM2
- d. Bloccare viti 1



### K02

A RICHIESTA AUTORADIAL SPECIALI



REF.	Fmm/∅	K02 AR 125 CODE	K02 AR 160 CODE
K02 AR...- F.0.05 ± 0.005	0.05	500612520050	500616020050
K02 AR...- F.0.1 ± 0.005	0.1	500612520100	500616020100
K02 AR...- F.0.2 ± 0.01	0.2	500612520200	500616020200
K02 AR...- F.0.3 ± 0.01	0.3	500612520300	500616020300
K02 AR...- F.0.4 ± 0.02	0.4	500612520400	500616020400
K02 AR...- F.0.5 ± 0.02	0.5	500612520500	500616020500
K02 AR...- F.0.6 ± 0.02	0.6	500612520600	500616020600

### K-NC

### MHD'

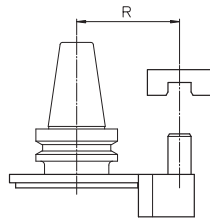

REF.	R.80 CODE	R.110 CODE
K-NC R... - AR 125	394112508002	394112511002
K-NC R... - AR 160	394116008002	394116011003

REF.	MHD'	Gamma completa dei coni a pag.10
AR 125	63	
AR 160	80	

### P110

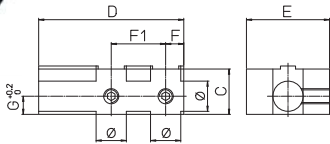

REF.	CODE	∅H7	C	D	E	F	F1	G	Kg.
AR 125 - P 110	433056381200	25	39	121	56	15	45.5	16	1.3
AR 160 - P 110	433063481600	32	49	164	63	19	63	21	2.5

### AVANZAMENTI INTERCAMBIABILI

### F ...



REF.	Fmm/∅	K02 AR 125 CODE	K02 AR 160 CODE
F. 0.05-AR... ± 0.005	0.05	382006105001	382006205001
F. 0.1 - AR... ± 0.005	0.1	382006110001	382006210001
F. 0.2 - AR... ± 0.01	0.2	382006120001	382006220001
F. 0.3 - AR... ± 0.01	0.3	382006130001	382006230001
F. 0.4 - AR... ± 0.02	0.4	382006140001	382006240001
F. 0.5 - AR... ± 0.02	0.5	382006150001	382006250001
F. 0.6 - AR... ± 0.02	0.6	382006160001	382006260001

Per un buon impiego della testa AUTORADIAL e per salvaguardarne l'integrità è consigliato seguire il grafico sottostante che indica il numero di giri massimo in funzione della corsa della slitta.

### MAX VELOCITÀ DI ROTAZIONE

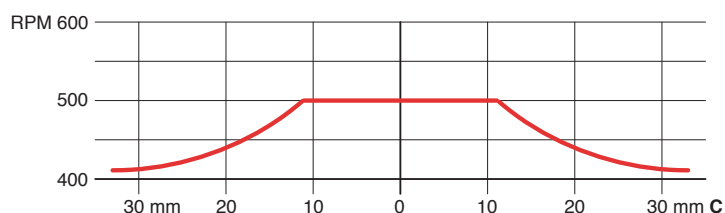

# CAPACITÀ DI ASPORTAZIONE

Le asportazioni sono indicative per condizioni di lavoro normali su acciai con durezza 160-200 HB, (Ks medio = 2000 N/mm<sup>2</sup>)  
Vt consigliata 120/160m/min.

I valori ottimali ed i tempi di lavoro dovranno essere determinati con delle prove.



	AR 125	AR 160
F	25	32
D1 max	99	144
L1	160	200
D2 max	190	270
L2	160	200
D3 max	320	400
L3	40	50

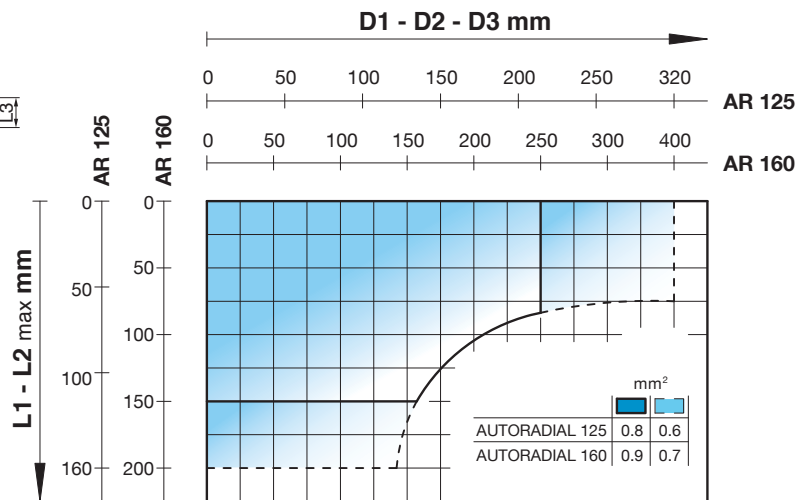

## DATI TECNICI

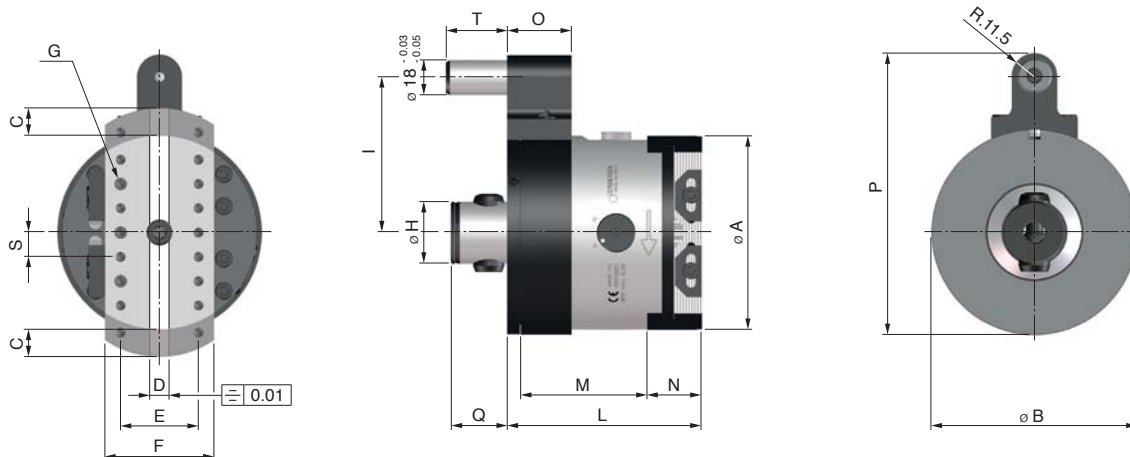

DATI TECNICI		AR 125	AR 160
Ø A	mm	125	160
Ø B	mm	130	130
C corsa radiale	mm	± 20	± 35
D	mm	10 <sup>+0.03</sup> <sub>0</sub>	12 <sup>+0.03</sup> <sub>0</sub>
E	mm	40	50
F	mm	63 <sup>-0.003</sup> <sub>-0.007</sub>	80 <sup>-0.003</sup> <sub>-0.007</sub>
G	mm	M5	M6
Ø H	mm	(MHD'63) 42 <sup>-0.005</sup> <sub>0.008</sub>	(MHD'63) 42 <sup>-0.005</sup> <sub>-0.008</sub>
I	mm	80/110	80/110
L	mm	110	125
M	mm	75	83
N	mm	28	35
O	mm	35	35
P	mm	156.5 / 186.5	171.5 / 201.5
Q	mm	38.5	44.5
S	mm	12.5	15
T	mm	39.5	45.5
Avanzamenti intercambiabili	mm/◊	pag. 140	pag. 140
Massima velocità	RPM	500	400
Peso senza cono	Kg	9	14
Ritorno rapido	mm/◊	0.8	0.8

# D'ANDREA IN ITALIA E NEL MONDO

TESTE VENDUTE  
350.000



*made in italy*



La sede D'Andrea a Lainate (Milano)



Lo stabilimento di Castel Del Giudice (Isernia)



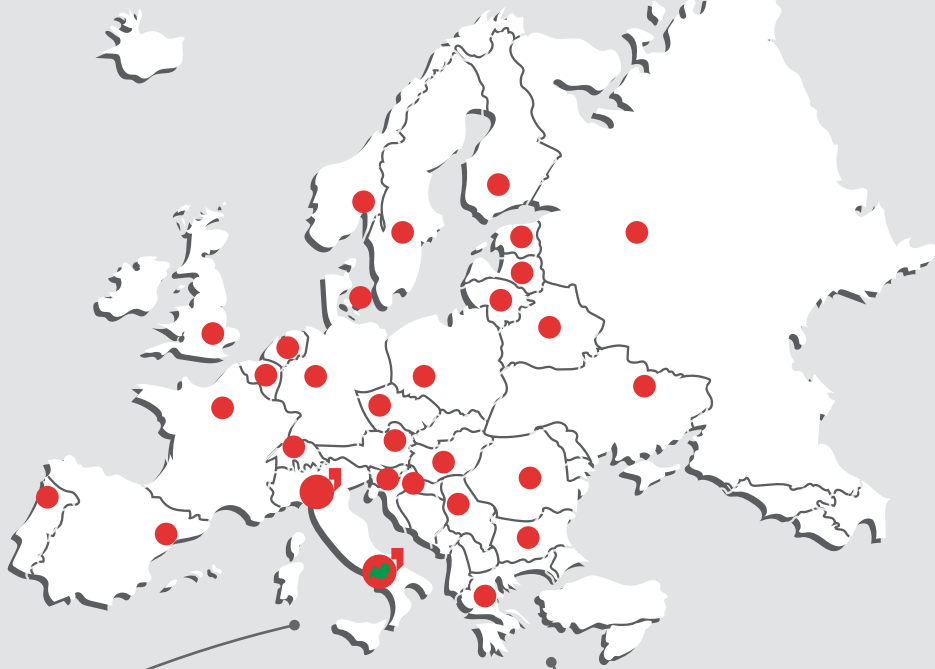

WE LOOK TO THE FUTURE...

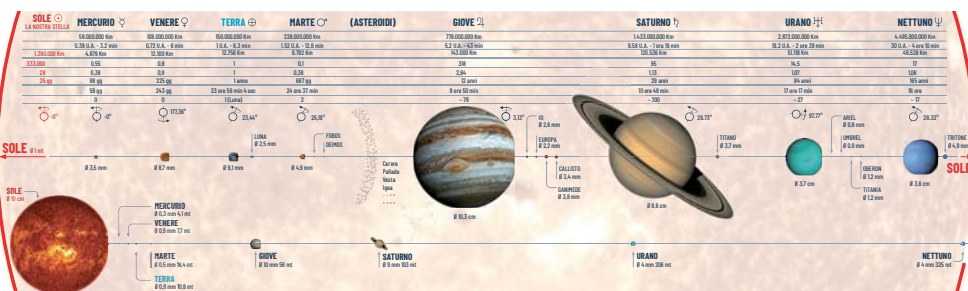

Show Room D'Andrea Lainate (Milano)



Sputnik

Apollo 14

10/21  
Cod. 181001001010

© **D'ANDREA s.p.a.**

Via Garbagnate 71 • 20045 Lainate (MI) Italy  
Tel. +39 02 937532.1 • Fax +39 02 93753240  
www.dandrea.com • info@dandrea.com

**Prodotto da**

Ufficio Marketing  
D'ANDREA s.p.a. - Lainate (MI)

Le caratteristiche tecniche indicate in questo catalogo non sono impegnative e possono essere modificate anche senza preavviso.

# D'ANDREA

Via Garbagnate, 71 - 20045 Lainate (MI) Italy  
t. +39 02.937532.1 - f. +39 02.93753240  
info@dandrea.com - www.dandrea.com



10/21  
Cod. 181001001010